



Energy Management System
Installation and Operation Manual
(EU)

Revision Log

Version	Date	Rationale
V1.0	Apr 25, 2023	Initial version.
V1.1	May 25, 2023	Added a compatible energy meter. Modified the maximum wire length between the primary charger and the meter.
V2.0	Sept. 19, 2023	Optimized the structure. Added PV Hybrid mode w/multiple chargers. Added EMS mode.
V2.1	Dec. 8, 2023	Added a Wi-Fi connection option for connecting primary charger to router. The connection between primary charger and router can be accomplished using either an Ethernet cable or Wi-Fi.
V3.0	Jul. 20, 2024	Added the Energy Management System Solution for AC Ultra, AC Compact, DC Compact, DC Fast and other different usage scenarios.
V4.0	Feb. 7, 2026	Added the Energy Management System Solution for Single Charger, Single Charger + AC Ultra/AC Wallbox/AC Compact and other different usage scenarios. Added the Energy Management System configuration method: via Autel Operation and Maintenance Platform (O&M). Added register addresses of each model of device.
V4.1	Feb. 10, 2026	Updated system diagrams.

Trademarks

Autel® and MaxiCharger® are trademarks of Autel Intelligent Technology Corp., Ltd., registered in China, the United States, and other countries. All other marks are trademarks or registered trademarks of their respective holders.

Copyright Information

No part of this manual may be reproduced, stored in a retrieval system or transmitted, in any form or by any means, electronic, mechanical, photocopying, recording, or otherwise without the prior written permission of Autel.

Disclaimer of Warranties and Limitation of Liabilities

All information, specifications and illustrations in this manual are based on the latest information available at the time of printing.

Autel reserves the right to make changes at any time without notice. While information of this manual has been carefully checked for accuracy, no guarantee is given for the completeness and correctness of the contents, including but not limited to the product specifications, functions, and illustrations.

Autel will not be liable for any direct, special, incidental, indirect damages or any economic consequential damages (including the loss of profits).

IMPORTANT

Before installing and operating the Autel Energy Management System, please read this manual carefully, paying extra attention to the important notes.

For Services and Support:

Web: www.autelenergy.eu

Tel: 00-800-0825-1039 (United Kingdom, Netherlands, Germany, France, Italy, Switzerland)

00-800-0825-1052 (Denmark, Iceland)

20798959 (Sweden)

Working Time: Monday-Friday, CET 9:00 AM-6:00 PM, local working days

Email: evsupport.eu@autel.com

Address: Laan van Waalhaven 217, 2497GL 's-Gravenhage, the Netherlands

For technical assistance in all other markets, please contact your local selling agent.

Contents

1	Using This Manual	1
1.1	Conventions	1
1.1.1	<i>Bold Text</i>	1
1.1.2	<i>Notes and Important Messages</i>	1
1.1.3	<i>Hyperlinks</i>	1
1.1.4	<i>Illustrations</i>	1
2	Energy Management System	2
2.1	Operating Modes	2
2.2	Grouping Principle	4
2.3	General Features	5
2.4	Methods for Configuration	9
3	Installation	10
3.1	System Diagram	10
3.1.1	<i>For Single Charger</i>	12
3.1.2	<i>For AC Ultra/AC Wallbox/AC Compact</i>	19
3.2	Wiring Ethernet Cable	31
3.2.1	<i>For Single Charger</i>	31
3.2.2	<i>For SmartBox</i>	32
3.2.3	<i>For AC Wallbox</i>	33
3.2.4	<i>For AC Compact</i>	34
3.2.5	<i>For AC Ultra</i>	34
3.2.6	<i>For DC Compact</i>	35
3.2.7	<i>For DC Fast</i>	36
3.3	Wi-Fi Connection	36
3.3.1	<i>For Single Charger</i>	36
3.3.2	<i>For SmartBox</i>	36

3.3.3	<i>For AC Wallbox/AC Compact</i>	37
3.3.4	<i>For AC Ultra/DC Compact/DC Fast</i>	40
3.4	Wiring RS-485 Cable.....	43
3.4.1	<i>For Single Charger</i>	43
3.4.2	<i>For AC Wallbox</i>	44
3.4.3	<i>For AC Compact</i>	48
3.4.4	<i>For AC Ultra</i>	52
3.4.5	<i>For DC Compact</i>	59
3.4.6	<i>For DC Fast</i>	60
4	Configuration	61
4.1	Configuration through the Web.....	62
4.1.1	<i>For Scenarios with Commercial Environments</i>	62
4.2	Configuration on the Charger.....	74
4.2.1	<i>For Scenario with AC Ultra/DC Compact/DC Fast</i>	74
4.2.2	<i>For Scenarios with Chargers of Different Models</i>	98
4.3	Configuration via the Autel ChargeAPP.....	112
4.3.1	<i>For Scenarios with Single Charger</i>	112
4.3.2	<i>For Scenario with AC Wallbox/AC Compact</i>	122
5	Modbus Register	147
5.1	Read Input Register.....	147
5.2	Read Holding Register.....	147
5.3	Write Single Holding Register.....	148
5.4	Write Multiple Holding Registers.....	148
5.5	Register Specifications.....	149
5.6	Register Addresses.....	155
6	Energy Management Strategies	168

1 Using This Manual

This manual is intended to outline the Energy Management System Solution for Autel EU model MaxiChargers — AC Wallbox, AC Compact, AC Ultra, DC Compact, DC Fast and Single Charger. It describes the operating modes supported by the Autel Energy Management System as well as the installation and configuration instructions.

This document is intended for the following:

- Owners of Autel EU model AC/DC MaxiChargers — AC Wallbox, AC Compact, AC Ultra, DC Compact, DC Fast and Single Charger
- Certified electricians/installers

1.1 Conventions

The following conventions are used:

1.1.1 Bold Text

Bold text is used to highlight selectable items such as buttons and menu options.

1.1.2 Notes and Important Messages

NOTE

Provides helpful information such as additional explanations, tips, and comments.

IMPORTANT

Reminds you that you must follow the instructions to prepare, set up, configure, and operate.

1.1.3 Hyperlinks

Hyperlinks are available in electronic documents. Blue italic text indicates a selectable hyperlink, and blue underlined text indicates a website link or an email address link.

1.1.4 Illustrations

Illustrations, especially the screenshots of the interface used in this document are for reference only. The actual product and screens may differ.

2 Energy Management System

The Autel Energy Management System offers four operating modes. You can select a mode based on the different usage scenarios.

2.1 Operating Modes

A. DLB Mode

The purpose of DLB mode is to achieve the fastest charging by maximizing power efficiency for the power allocated to the chargers and keeping the system power within a specific range.

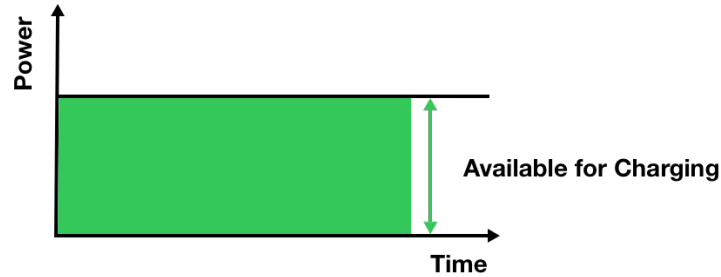

B. ALM Mode

ALM mode provides consistent charging of chargers and other loads. The difference between ALM mode and DLB mode is that ALM mode manages load power and charger power at the same time using an external energy meter.

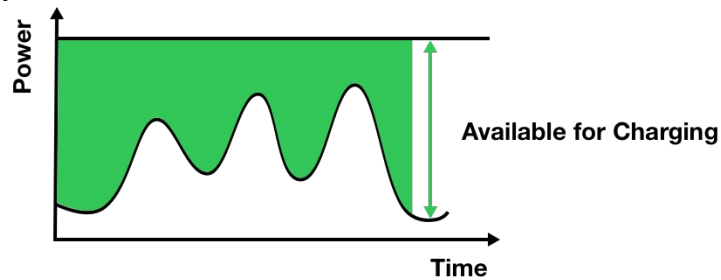

C. PV Hybrid Mode

PV Hybrid mode is achieved using solar energy. In PV Hybrid mode, the renewable electricity will be prioritized for household loads, and the surplus renewable electricity will be provided for your chargers to charge vehicles.

There are three charging modes available to meet your diversified charging demands.

1) Full Green Charging Mode

The primary charger will always dynamically allocate the surplus renewable electricity to all chargers. No grid power will be provided even if the surplus renewable electricity is insufficient.

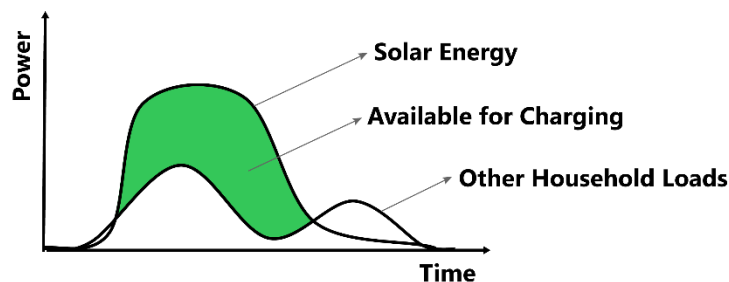

2) Green Priority Charging Mode

When the surplus renewable electricity is more than the sum of the minimum charging power of all chargers, the surplus renewable electricity will be dynamically allocated to all chargers through the primary charger. When the surplus renewable electricity is less than the sum of the minimum charging power of all chargers, the grid will provide extra power to meet the minimum charging power required by the chargers, and all chargers will charge at their minimum charging power.

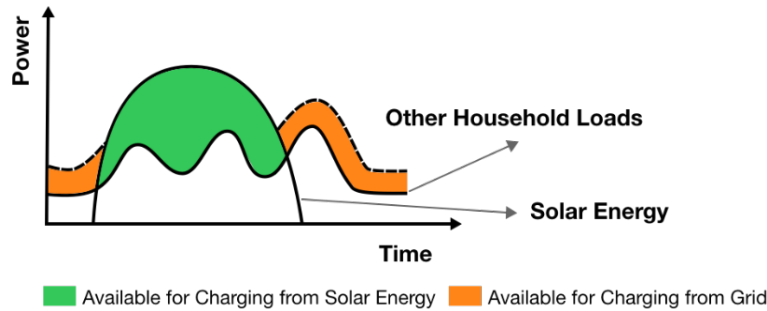

3) Speed Priority Charging Mode

The chargers will receive power from both the solar energy and the grid power. After supplying power to other household loads, the surplus solar energy and grid power will be utilized to charge the chargers.

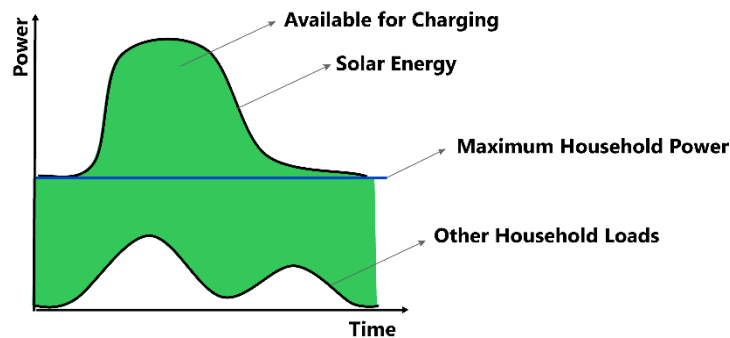

D. EMS Mode

In this mode, the third-party EMS assumes the role of the Controller, while the charger operates as the Receiver, adhering to power control commands issued by the EMS. The third-party EMS is responsible for load balancing and managing the power output of all Receivers.

2.2 Grouping Principle

Scenario	Primary Device	Secondary Charger
Single Charger	Single Charger	Single Charger
Single Charger + AC Ultra/ AC Elite(Wallbox)/AC Compact	Single Charger	AC Ultra/AC Elite (Wallbox)/AC Compact
SmartBox + Single Charger	SmartBox	Single Charger
SmartBox + Single Charger/ AC Ultra/AC Elite(Wallbox)/AC Compact	SmartBox	Single Charger/AC Ultra/ AC Elite(Wallbox)/AC Compact
AC Wallbox/AC Compact	AC Wallbox/AC Compact	AC Wallbox/AC Compact
AC Ultra	AC Ultra	AC Ultra
DC Compact/DC Fast	DC Compact/DC Fast	DC Compact/DC Fast
AC Ultra + AC Wallbox/AC Compact	AC Ultra	AC Wallbox/AC Compact
DC Compact/DC Fast + AC Wallbox/AC Compact	DC Compact/DC Fast	AC Wallbox/AC Compact

NOTE

The DLB, ALM, and PV Hybrid mode will be set on the primary device.

For EMS mode, the charger acts as the secondary charger, and the operating mode will be set on every charger grouped up.

For DC Compact/DC Fast, PV Hybrid mode is not supported yet.

2.3 General Features

The table below describes the general features of the operating modes for Single Charger.

General Features of the Operating Modes

Item	DLB Mode	ALM Mode	PV Hybrid Mode	EMS Mode
Primary Charger	1	1	1	N/A
Secondary Charger	Max. 40	Max. 40	Max. 40	N/A
Network Connection Between Chargers	Wi-SUN/Wi-Fi/Ethernet	Wi-SUN/Wi-Fi/Ethernet	Wi-SUN/Wi-Fi/Ethernet	Wi-Fi/Ethernet

The table below describes the general features of the operating modes for SmartBox, Single Charger and the scenario where SmartBox is combined with Single Charger.

General Features of the Operating Modes

Item	DLB Mode	ALM Mode	PV Hybrid Mode
Primary Device	1	1	1
Secondary Charger	Max. 40 for a single circuit Max. 200 for multiple circuits	Max. 40 for a single circuit Max. 200 for multiple circuits	Max. 40 for a single circuit Max. 200 for multiple circuits
Network Connection Between Chargers	Wi-SUN/Wi-Fi/Ethernet	Wi-SUN/Wi-Fi/Ethernet	Wi-SUN/Wi-Fi/Ethernet

The table below describes the general features of the operating modes for Single Charger, AC Ultra, AC Elite(Wallbox), AC Compact and the scenarios where Single Charger is combined with AC Ultra/AC Elite(Wallbox)/AC Compact.

General Features of the Operating Modes

Item	DLB Mode	ALM Mode	PV Hybrid Mode	EMS Mode
Primary Charger	1	1	1	N/A
Secondary Charger	Max. 40	Max. 40	Max. 40	N/A
Network Connection Between Chargers	Wi-Fi/Ethernet	Wi-Fi/Ethernet	Wi-Fi/Ethernet	Wi-Fi/Ethernet

The table below describes the general features of the operating modes for SmartBox, Single Charger, AC Ultra, AC Elite(Wallbox), AC Compact and the scenarios where SmartBox is combined with Single Charger/AC Ultra/AC Elite(Wallbox)/AC Compact.

General Features of the Operating Modes

Item	DLB Mode	ALM Mode	PV Hybrid Mode
Primary Device	1	1	1
Secondary Charger	Max. 40 for a single circuit Max. 200 for multiple circuits	Max. 40 for a single circuit Max. 200 for multiple circuits	Max. 40 for a single circuit Max. 200 for multiple circuits
Network Connection Between Chargers	Wi-Fi/Ethernet	Wi-Fi/Ethernet	Wi-Fi/Ethernet

The table below shows the general features of the operating modes for AC Wallbox and AC Compact.

General Features of the Operating Modes

Item	DLB Mode	ALM Mode	PV Hybrid Mode	EMS Mode
Primary Charger	1	1	1	N/A
Secondary Charger	Max. 7	Max. 7	Max. 7	N/A
Hardware Connection Between Charger and Router	Wi-Fi/Ethernet	Wi-Fi/Ethernet	Wi-Fi/Ethernet	Wi-Fi/Ethernet
Communications Protocol Between Primary Charger and Meter	N/A	Modbus	Modbus	N/A
Hardware Connection Between Primary Charger and Meter	N/A	RS-485 cable	RS-485 cable	N/A
Maximum Length of Ethernet Cable	100 m (328 ft.)	100 m (328 ft.) (For multiple chargers.)	100 m (328 ft.) (For multiple chargers.)	100 m (328 ft.)
Maximum Length Between the Wiring of Primary Charger and Meter	N/A	200 m (656 ft.)	200 m (656 ft.)	N/A

The table below shows the general features of the operating modes for AC Ultra, DC Compact, DC Fast and the scenarios including AC Ultra + AC Wallbox/AC Compact and DC Compact/DC Fast + AC Wallbox/AC Compact.

General Features of the Operating Modes

Item	DLB Mode	ALM Mode	PV Hybrid Mode	EMS Mode
Primary Charger	1	1	1	N/A
Secondary Charger	Max. 40	Max. 40	Max. 40	N/A
Hardware Connection Between Charger and Router	Wi-Fi/Ethernet	Wi-Fi/Ethernet	Wi-Fi/Ethernet	Wi-Fi/Ethernet
Communications Protocol Between Primary Charger and Meter	N/A	Modbus	Modbus	N/A
Hardware Connection Between Primary Charger and Meter	N/A	RS-485 cable	RS-485 cable	N/A
Maximum Length of Ethernet Cable	100 m (328 ft.)	100 m (328 ft.) (For multiple chargers.)	100 m (328 ft.) (For multiple chargers.)	100 m (328 ft.)
Maximum Length Between the Wiring of Primary Charger and Meter	N/A	200 m (656 ft.)	200 m (656 ft.)	N/A

2.4 Methods for Configuration

- For residential scenarios:

The Autel Energy Management System can be configured via either the Autel ChargeAPP or the Autel ConfigAPP.

Download the Autel ChargeAPP or Autel ConfigAPP by scanning the respective QR codes below or directly from the Apple App Store or Google Play Store, depending on the mobile device you are using.



ChargeAPP



ConfigAPP

NOTE

The Autel ChargeAPP is used to illustrate the examples in this manual.

The Autel ConfigAPP only supports AC Wallbox and AC Compact for the load balancing function.

- For commercial scenarios:

The Autel Energy Management System can be configured via <https://omcb-eu.autel.com/>.

3 Installation

3.1 System Diagram

NOTE

To comply with relevant electric leakage protection standards, please use at least a Type A RCD or an equivalent electrical leakage protector that complies with local standards for each MaxiCharger.

Installation must be performed by qualified personnel in accordance with local regulations.

The figures below are used to describe different charger models.

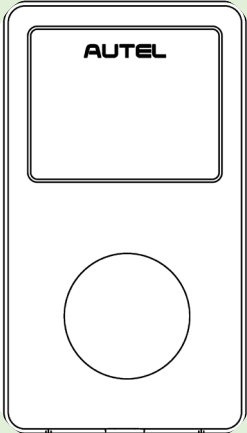
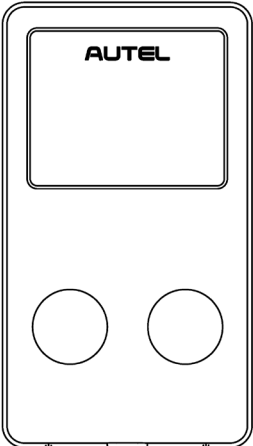
Figure	Description
	AC Wallbox/AC Compact
	AC Ultra/DC Compact/DC Fast

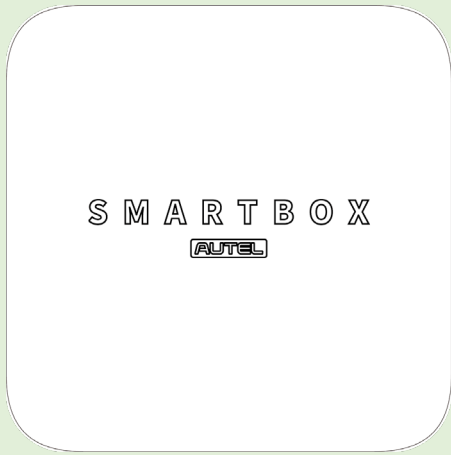

SmartBox



SmartSensor

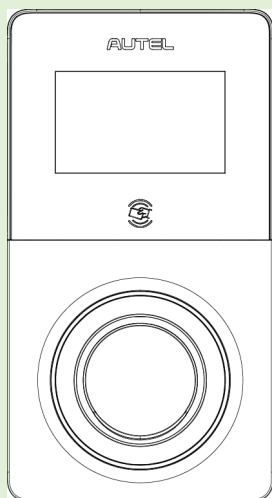

Single Charger

3.1.1 For Single Charger

3.1.1.1 DLB Mode

➤ For Single Charger

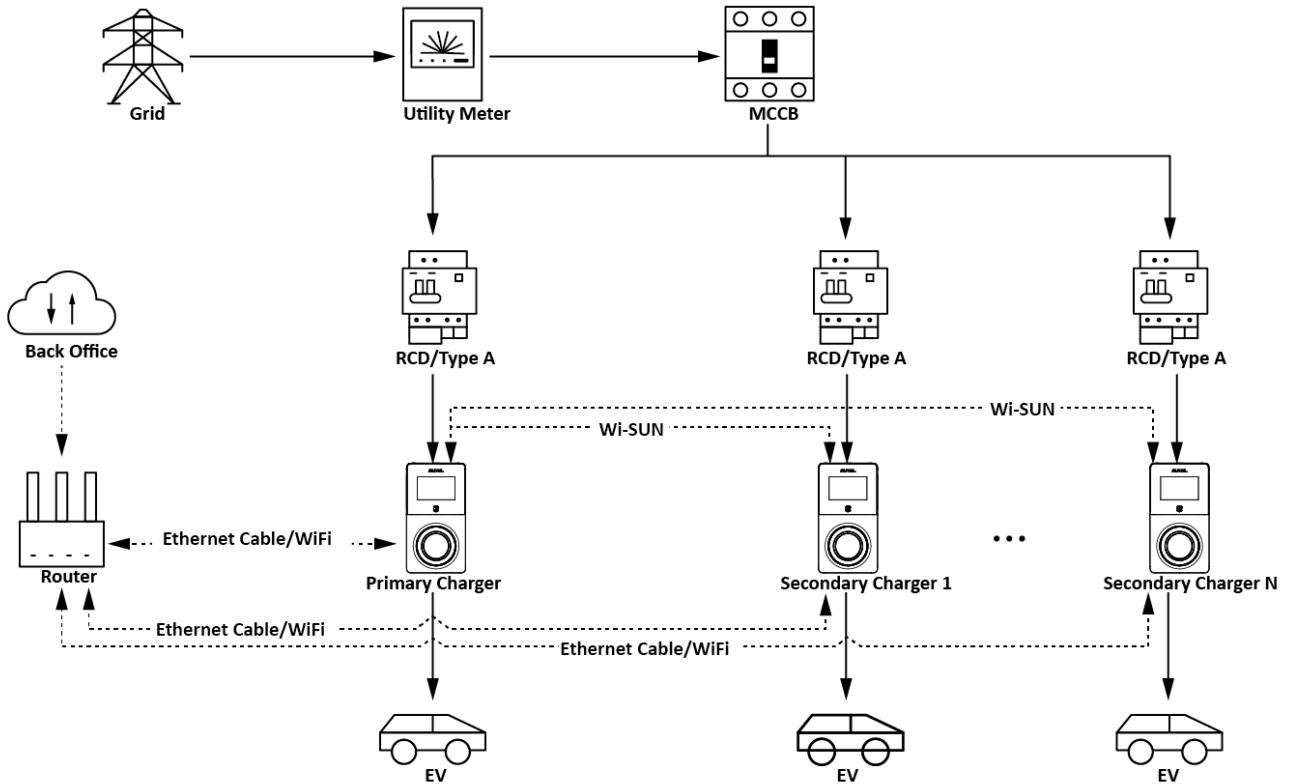

DLB Mode System Diagram

NOTE

Based on actual test results, the maximum communication distance of Wi-SUN in an open area is 200 meters. If there are obstacles in the area, the actual communication distance shall prevail.

If there is no obstructions between chargers at the installation site and the Wi-SUN signal strength is adequate ($\geq -75\text{dB}$), it is recommended to network the chargers locally via Wi-SUN. In this scenario, a router is optional, as the chargers can connect to the cloud directly via the 4G network.

If the installation site has a complex environment with a weak Wi-SUN signal, it is recommended to network the chargers locally via Ethernet or Wi-Fi. This configuration will require a router.

➤ For Single Charger + AC Ultra/AC Wallbox/AC Compact

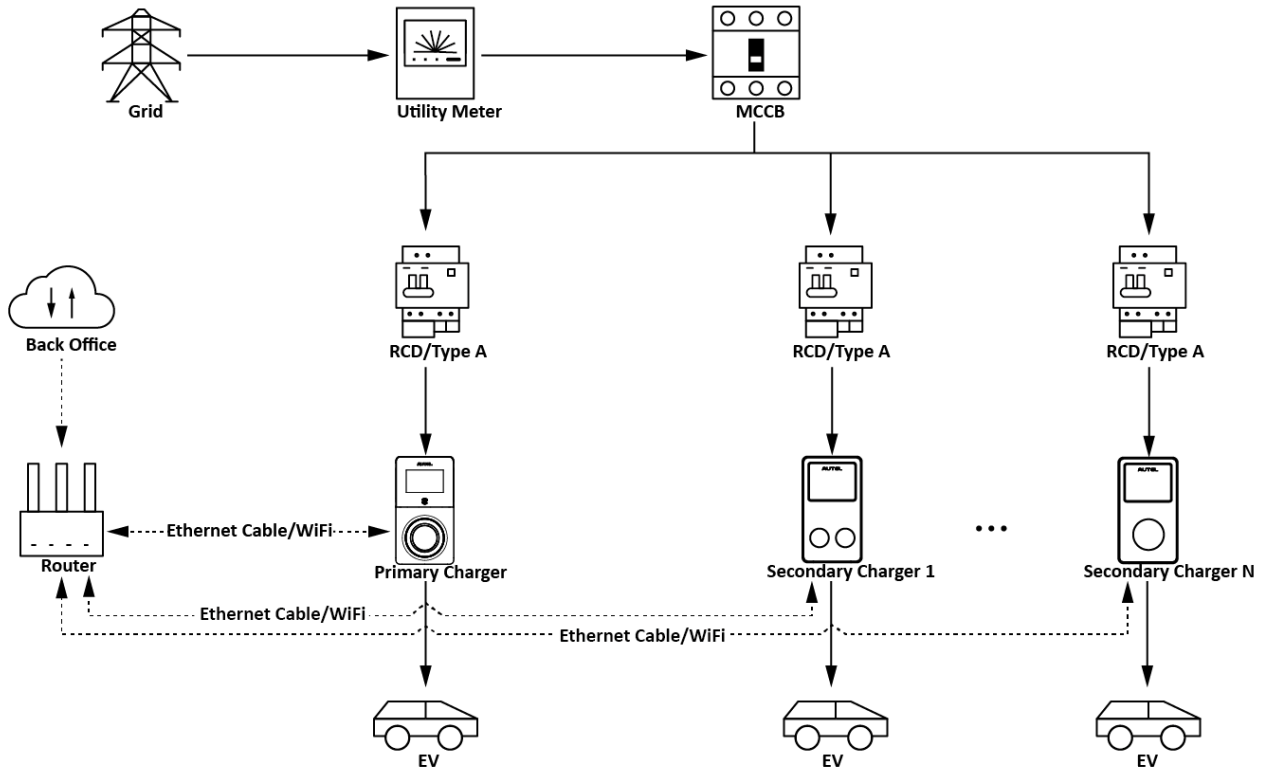

DLB Mode System Diagram

NOTE

For the scenario of Single Charger + AC Ultra/AC Wallbox/AC Compact, the chargers must use Ethernet or Wi-Fi for local networking.

3.1.1.2 ALM Mode

For Commercial Scenarios

➤ For SmartBox + Single Charger

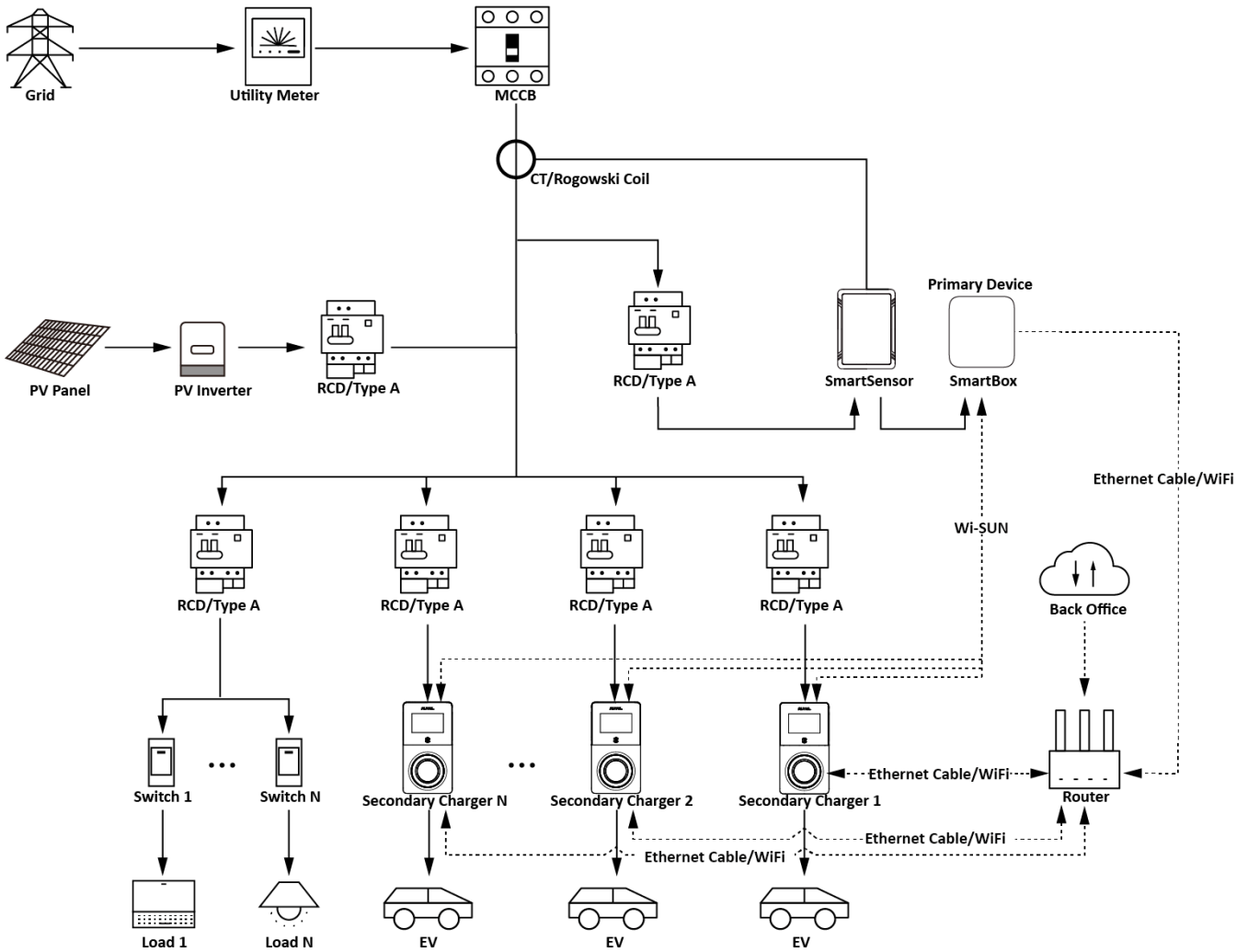

ALM Mode System Diagram

NOTE

The PV Panel and PV Inverter are optional components, to be included only if the actual installation site incorporates photovoltaic systems.

The specifications for the CT or Rogowski Coil should be selected according to the current rating.

If the installation site has a complex environment with a weak Wi-SUN signal, it is recommended to network the chargers locally via Ethernet or Wi-Fi. This configuration will require a router.

➤ For SmartBox + Single Charger/AC Ultra/AC Wallbox/AC Compact

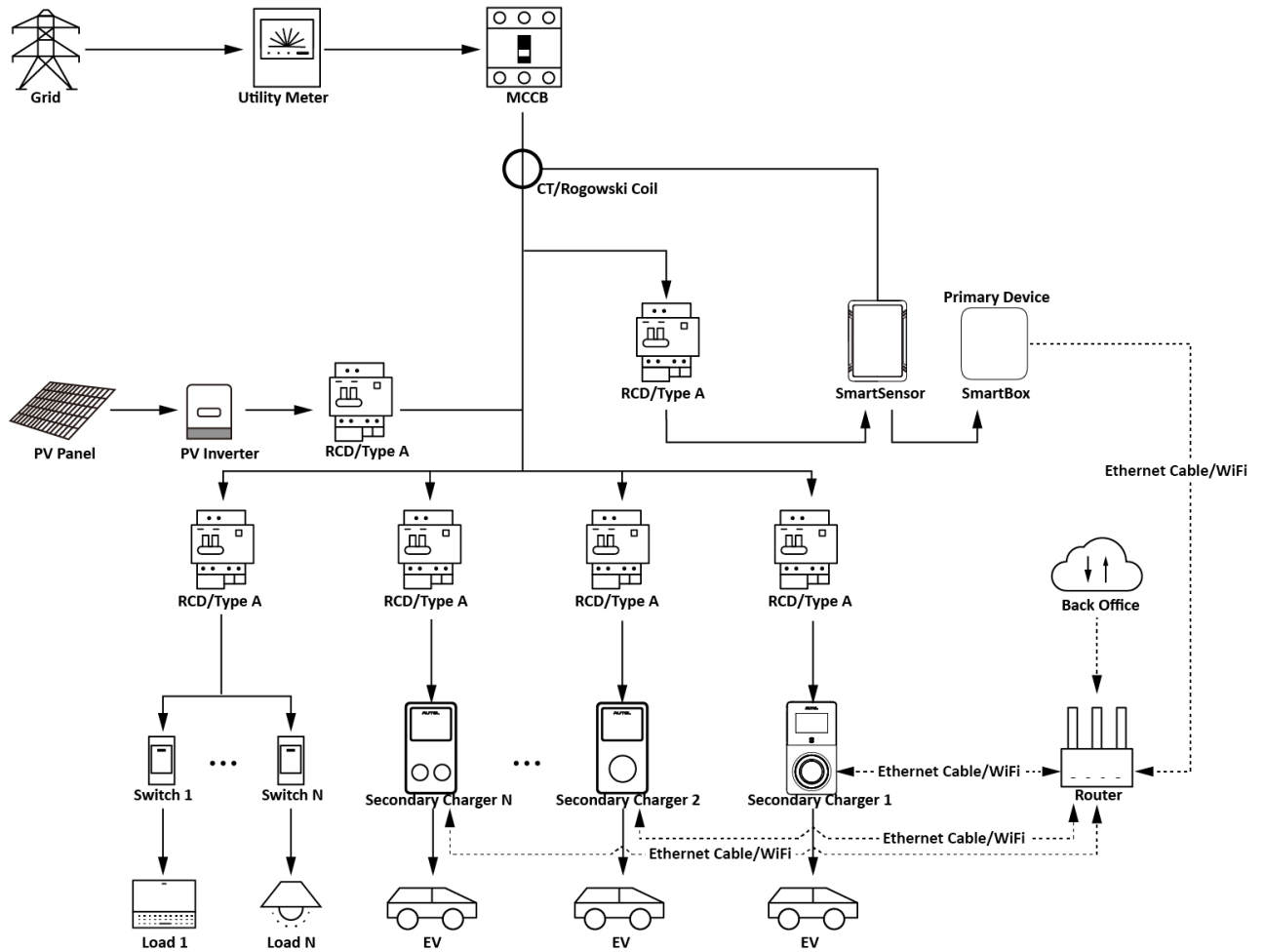

ALM Mode System Diagram

NOTE

For the scenario of Single Charger + AC Ultra/AC Wallbox/AC Compact, the chargers must use Ethernet or Wi-Fi for local networking.

For Residential Scenarios

➤ For Single Charger (using CT)

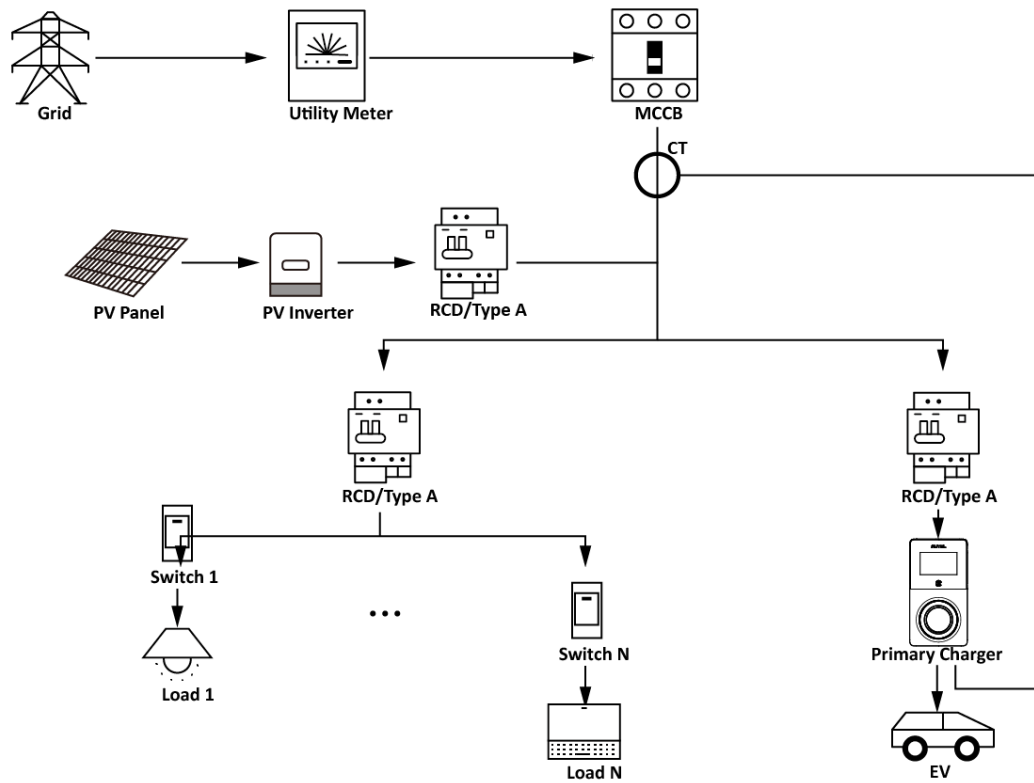

ALM Mode System Diagram

➤ For Single Charger (using Linky meter/P1 meter)

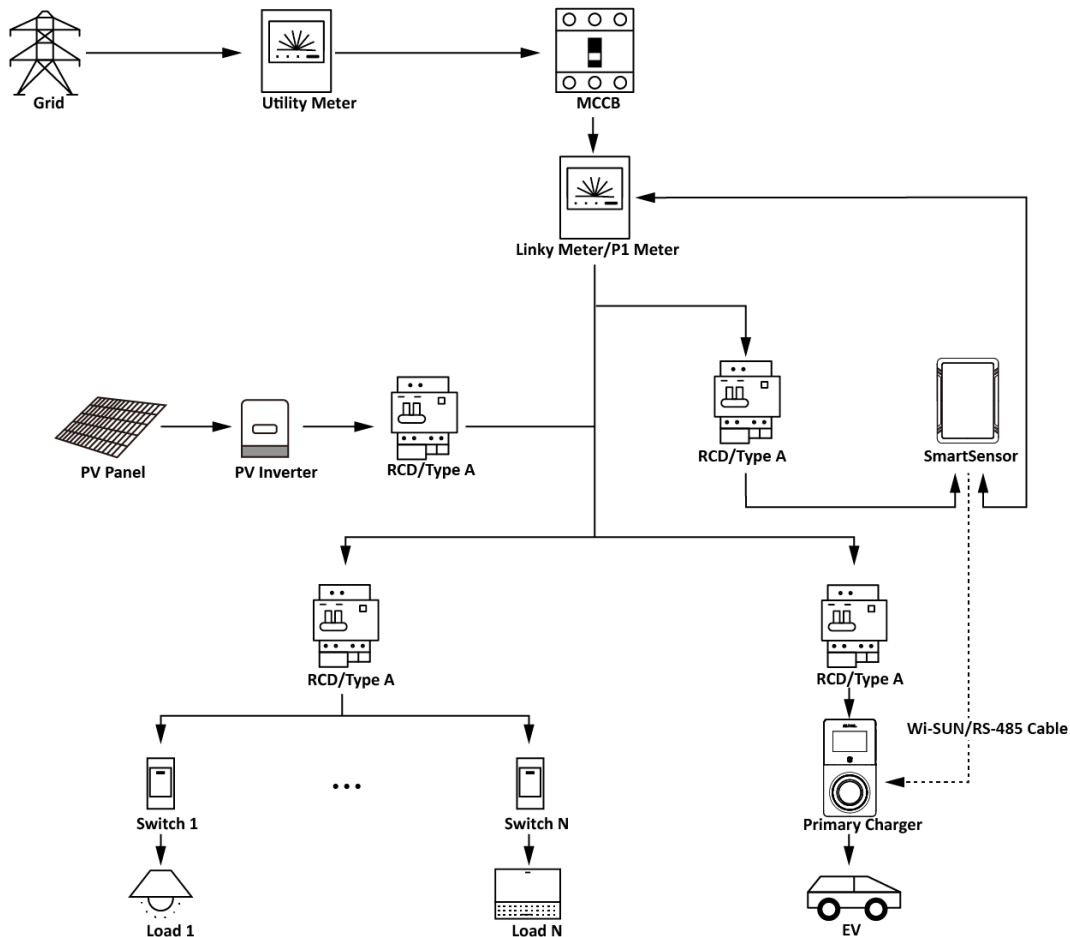

ALM Mode System Diagram

NOTE

Based on actual test results, the maximum communication distance of Wi-SUN in an open area is 200 meters. If there are obstacles in the area, the actual communication distance shall prevail.

When the Wi-SUN signal strength between the SmartSensor and the Single Charger is adequate ($\geq -75\text{dB}$), Wi-SUN networking is recommended. When the Wi-SUN signal strength between SmartSensor and Single Charger is insufficient, an RS-485 cable should be used to connect the SmartSensor and the Single Charger to ensure communication stability.

➤ For Single Charger (using Eastron meter)

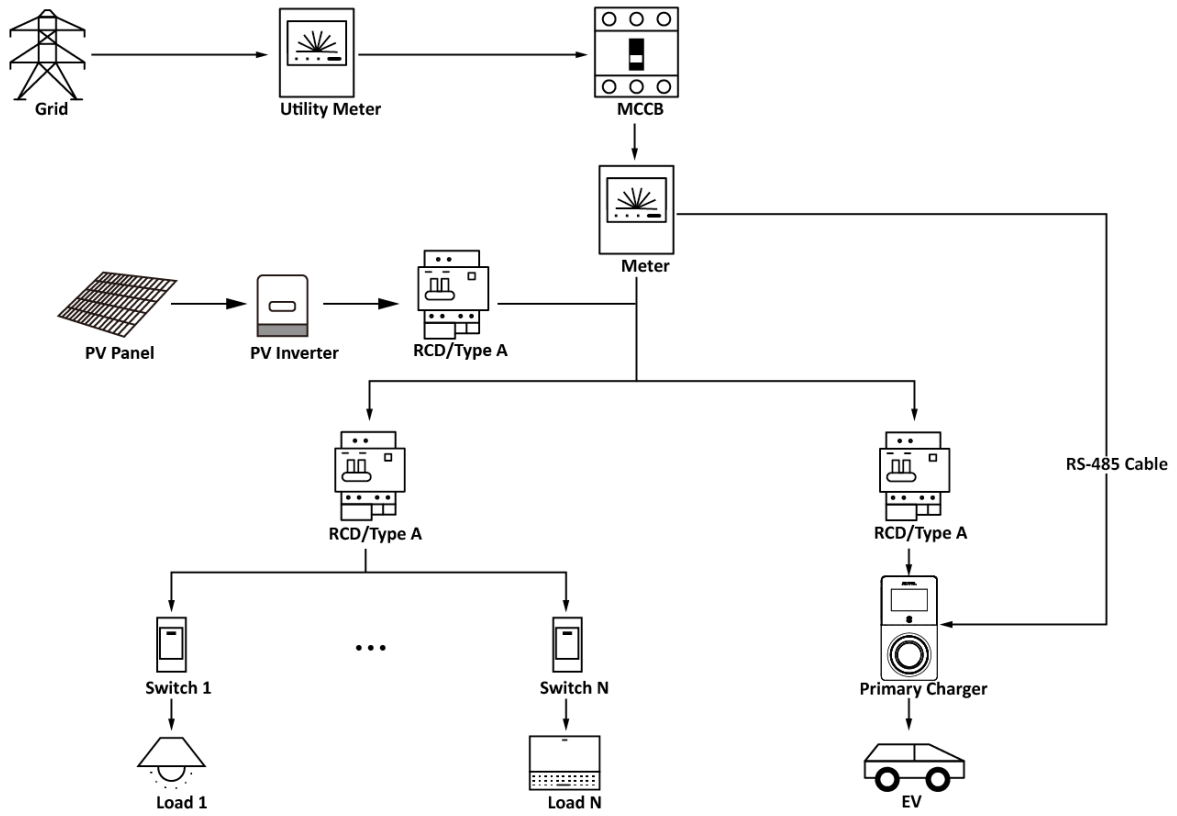

ALM Mode System Diagram

3.1.2 For AC Ultra/AC Wallbox/AC Compact

3.1.2.1 DLB Mode

DLB mode is implemented when there are multiple chargers and no other loads share the power. To use DLB mode, ensure that all prerequisites are met according to the system diagram.

➤ For AC Wallbox/AC Compact

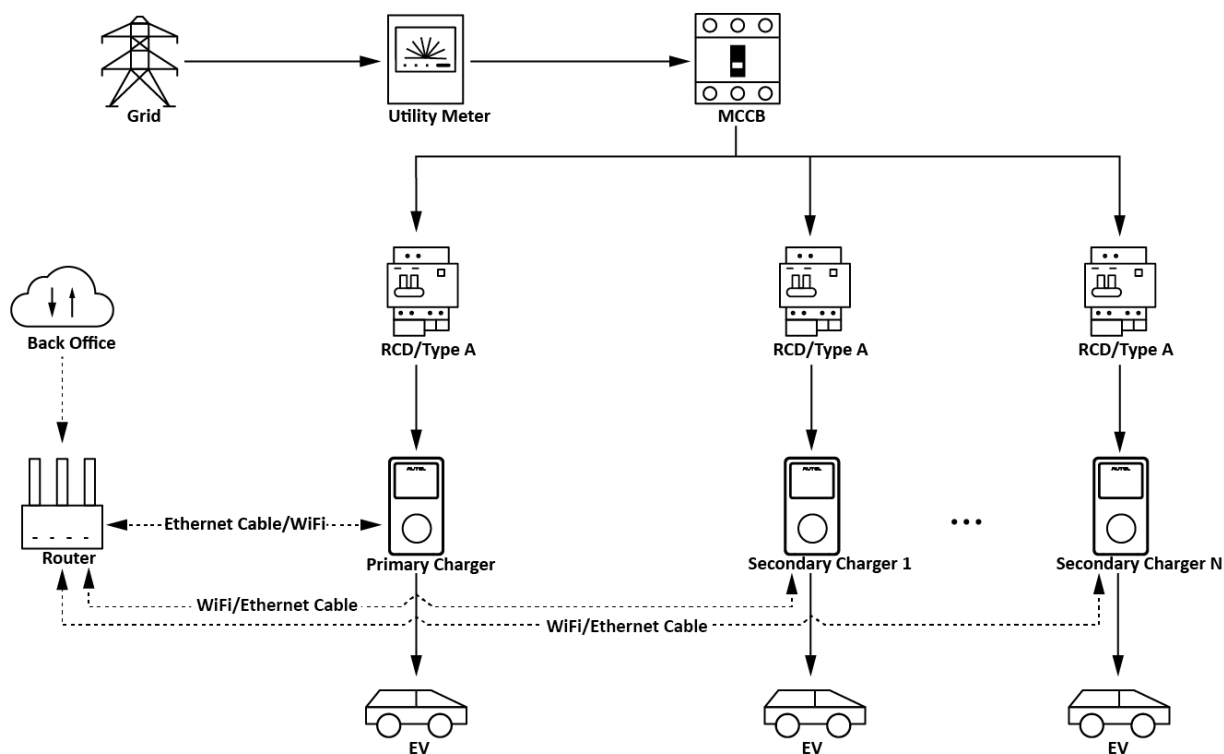

DLB Mode System Diagram

➤ For AC Ultra/DC Compact/DC Fast

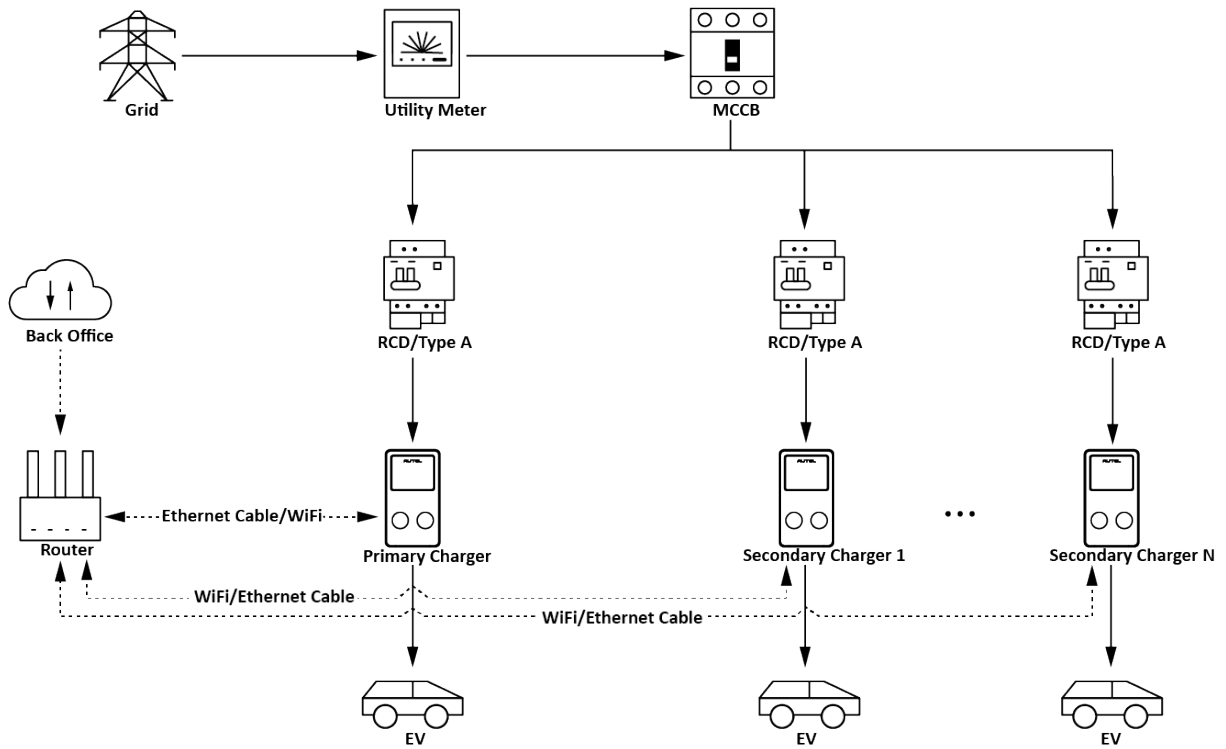

DLB Mode System Diagram

➤ For AC Ultra + AC Wallbox/AC Compact

For DC Compact/DC Fast + AC Wallbox/AC Compact

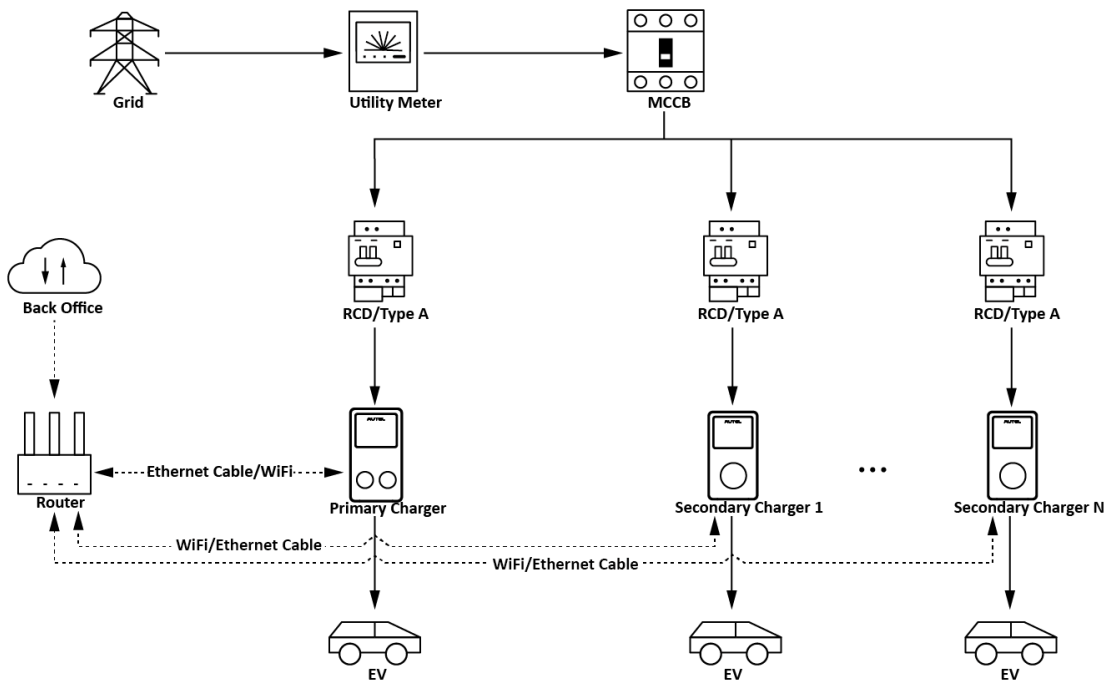

DLB Mode System Diagram

3.1.2.2 ALM Mode w/Individual Charger

ALM mode w/individual charger is suitable for cases where there is a Single Charger sharing power with other loads. To use ALM mode w/individual charger, ensure that all prerequisites are met according to the system diagram.

➤ **For AC Wallbox/AC Compact**

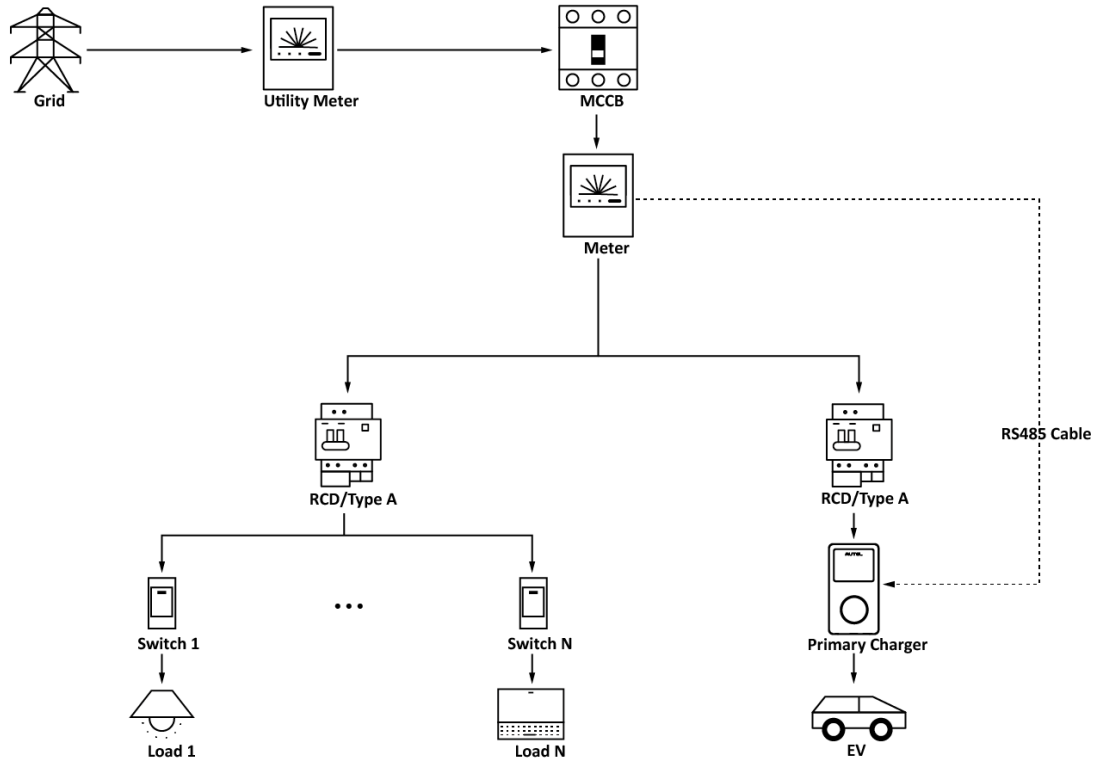

ALM Mode System Diagram (w/Individual Charger)

➤ For AC Ultra/DC Compact/DC Fast

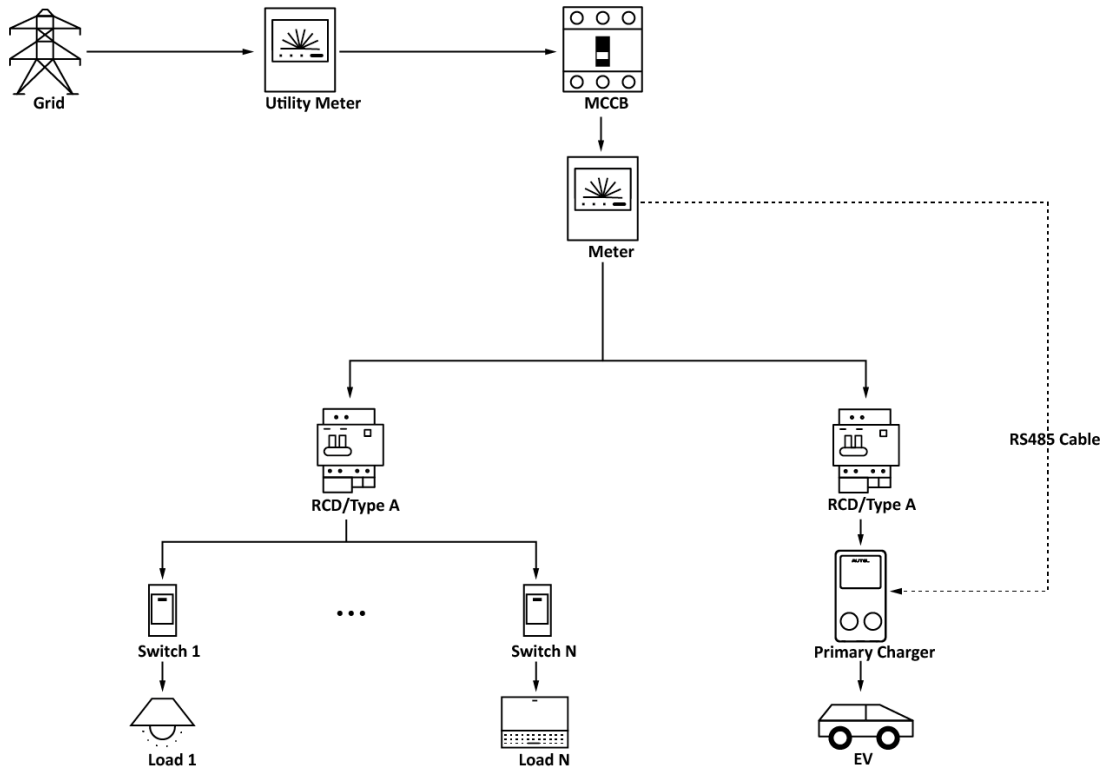

ALM Mode System Diagram (w/Individual Charger)

3.1.2.3 ALM Mode w/Multiple Chargers

ALM mode w/multiple chargers is suitable for cases where there are multiple chargers sharing power with other loads. To use ALM mode w/multiple chargers, ensure that all prerequisites are met according to the system diagram.

➤ **For AC Wallbox/AC Compact**

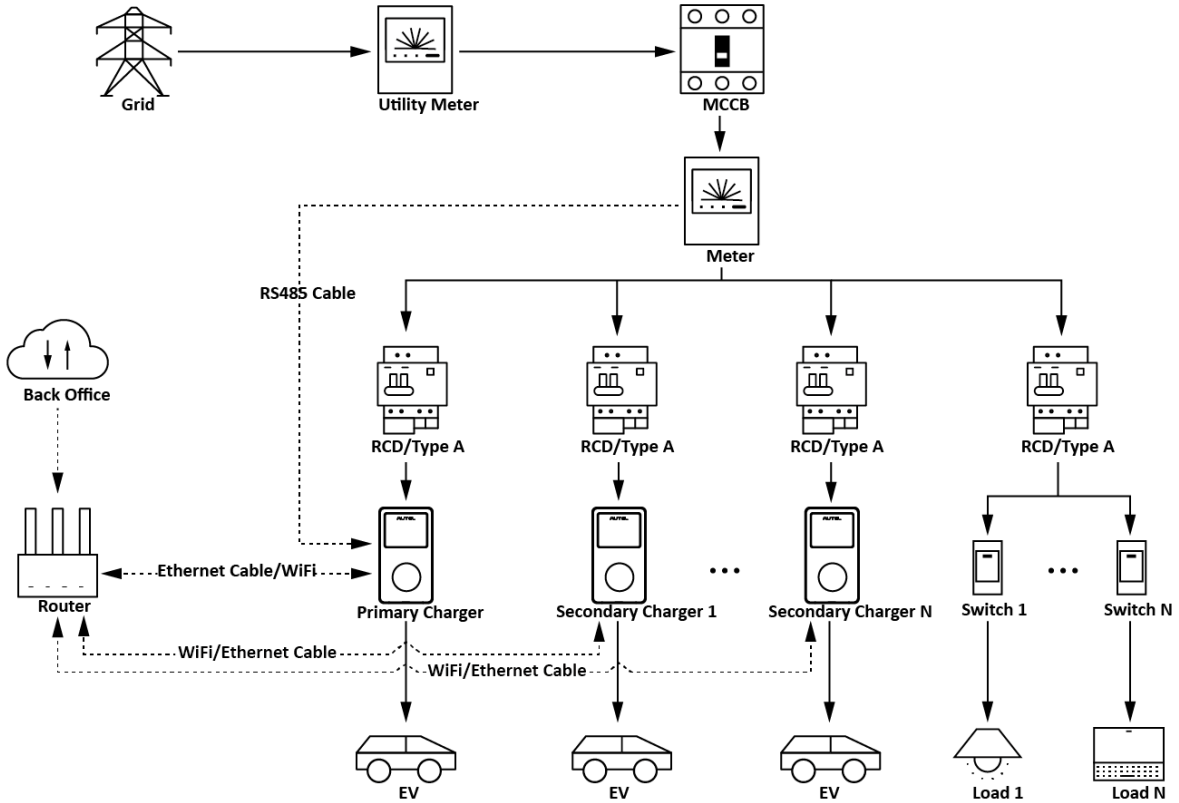

ALM Mode System Diagram (w/Multiple Chargers)

➤ For AC Ultra/DC Compact/DC Fast

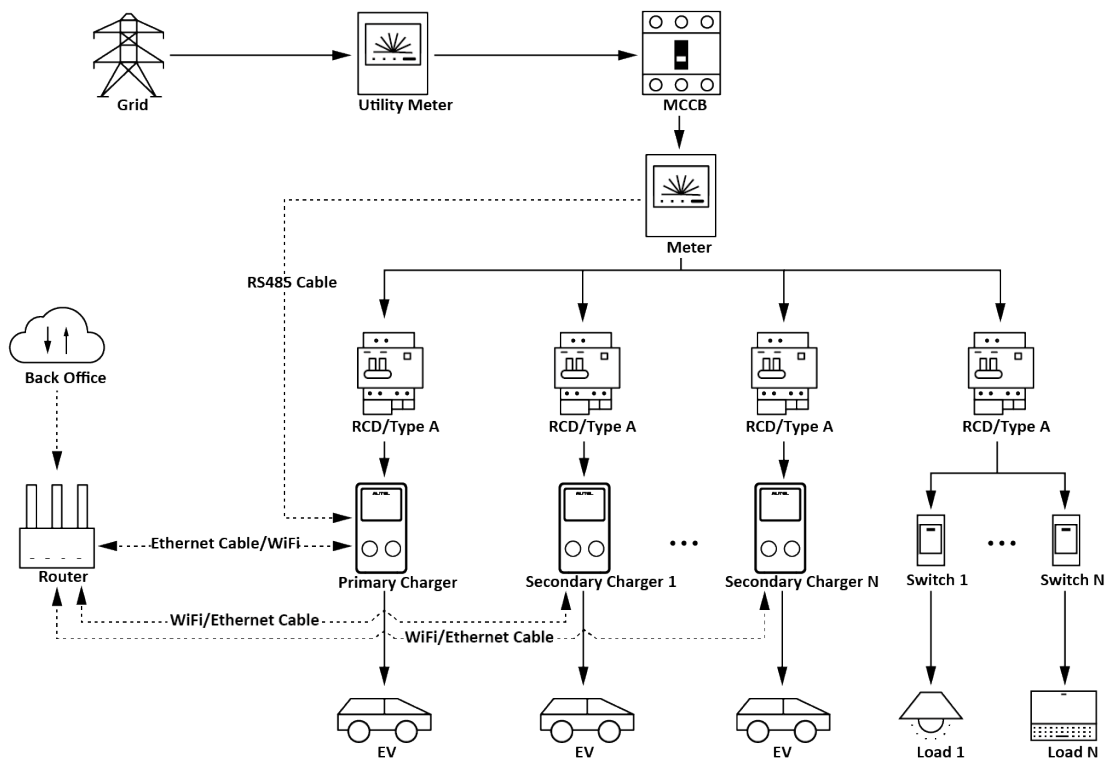

ALM Mode System Diagram (w/Multiple Chargers)

➤ For AC Ultra + AC Wallbox/AC Compact

For DC Compact/DC Fast + AC Wallbox/AC Compact

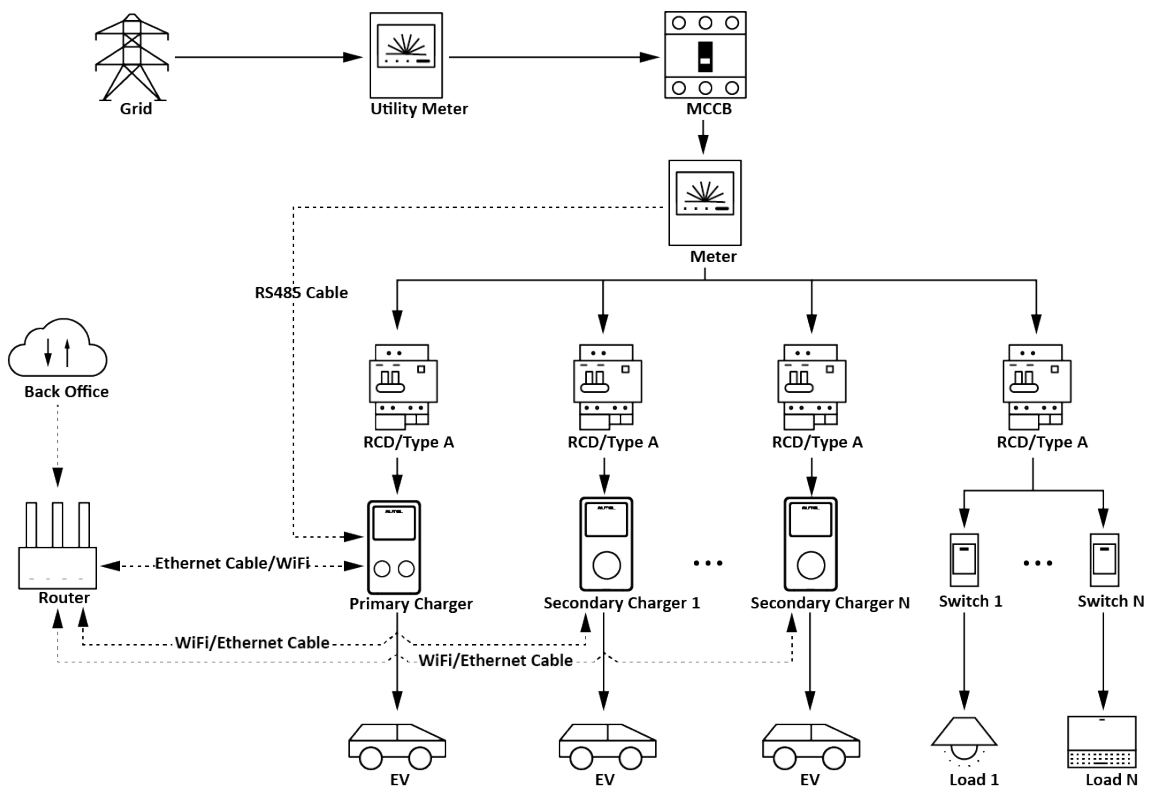

ALM Mode System Diagram (w/Multiple Chargers)

3.1.2.4 PV Hybrid Mode w/Individual Charger

PV Hybrid mode w/individual charger is suitable for cases where solar energy and electricity are used at the same time, and the solar energy is used preferentially to supply power for the charger and other loads.

➤ **For AC Wallbox/AC Compact**

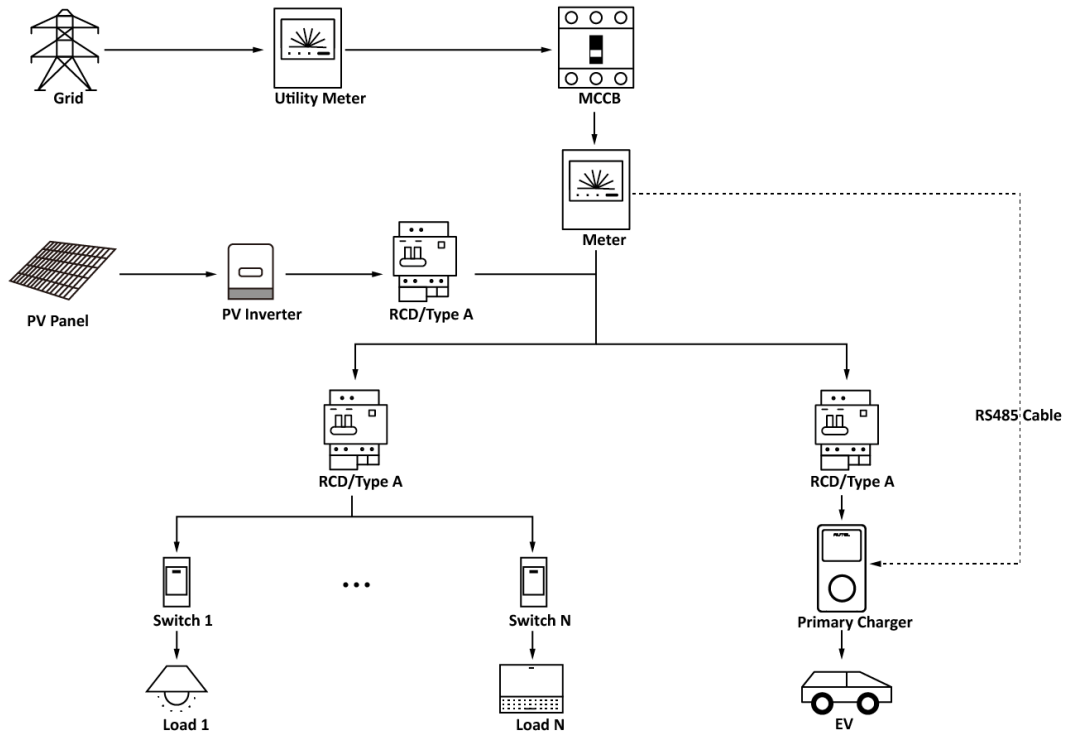

PV Hybrid Mode System Diagram (w/Individual Charger)

➤ For AC Ultra

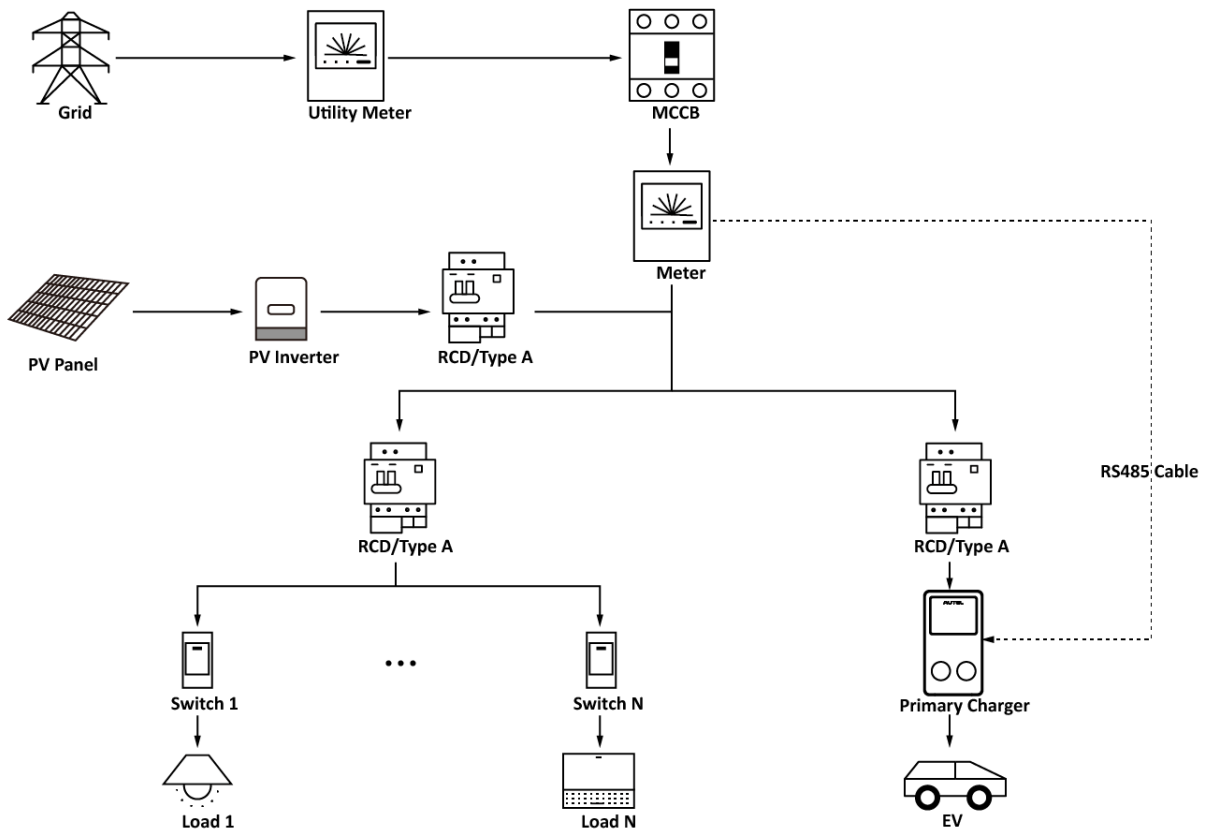

PV Hybrid Mode System Diagram (w/Individual Charger)

3.1.2.5 PV Hybrid Mode w/Multiple Chargers

PV Hybrid mode w/multiple chargers is suitable for cases where solar energy and electricity are used at the same time, and the solar energy is used preferentially to supply power for multiple chargers and other loads.

➤ **For AC Wallbox/AC Compact**

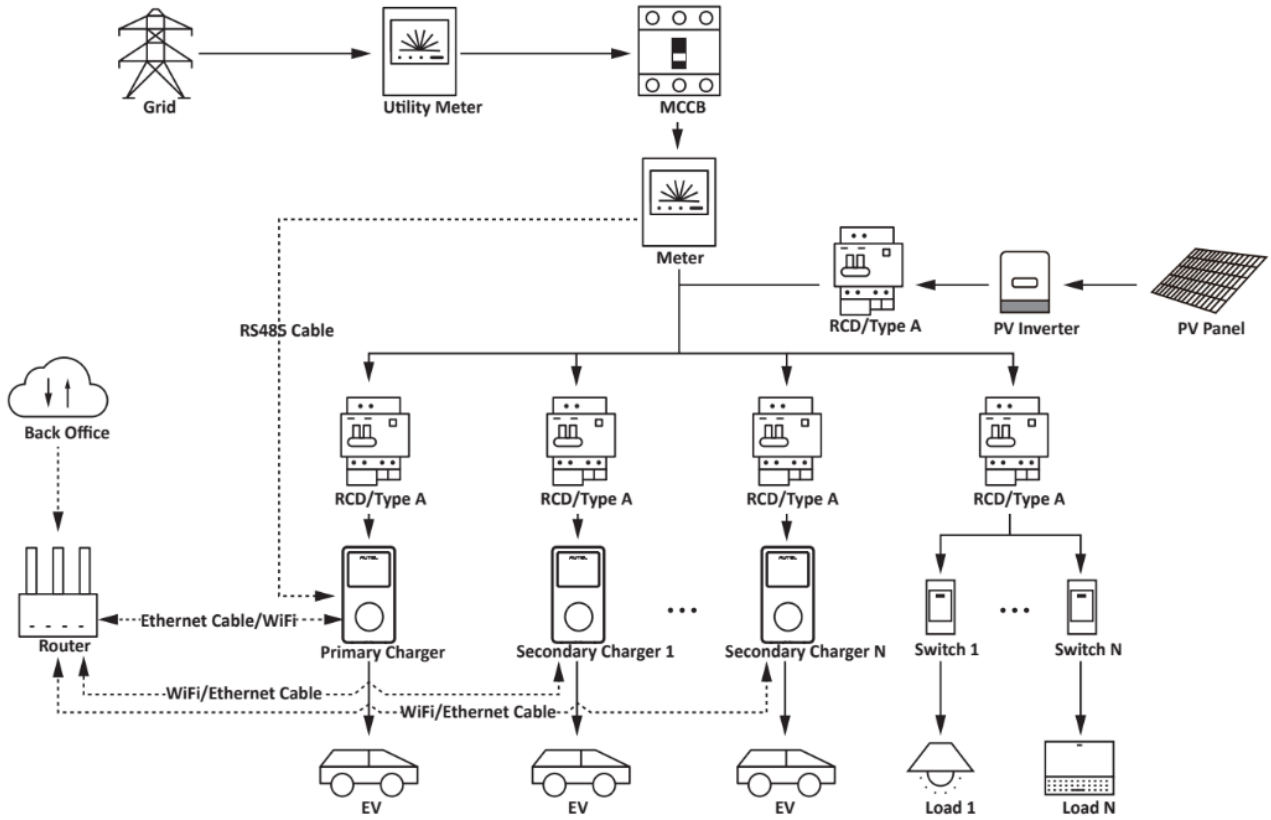

PV Hybrid Mode System Diagram (w/Multiple Chargers)

➤ For AC Ultra

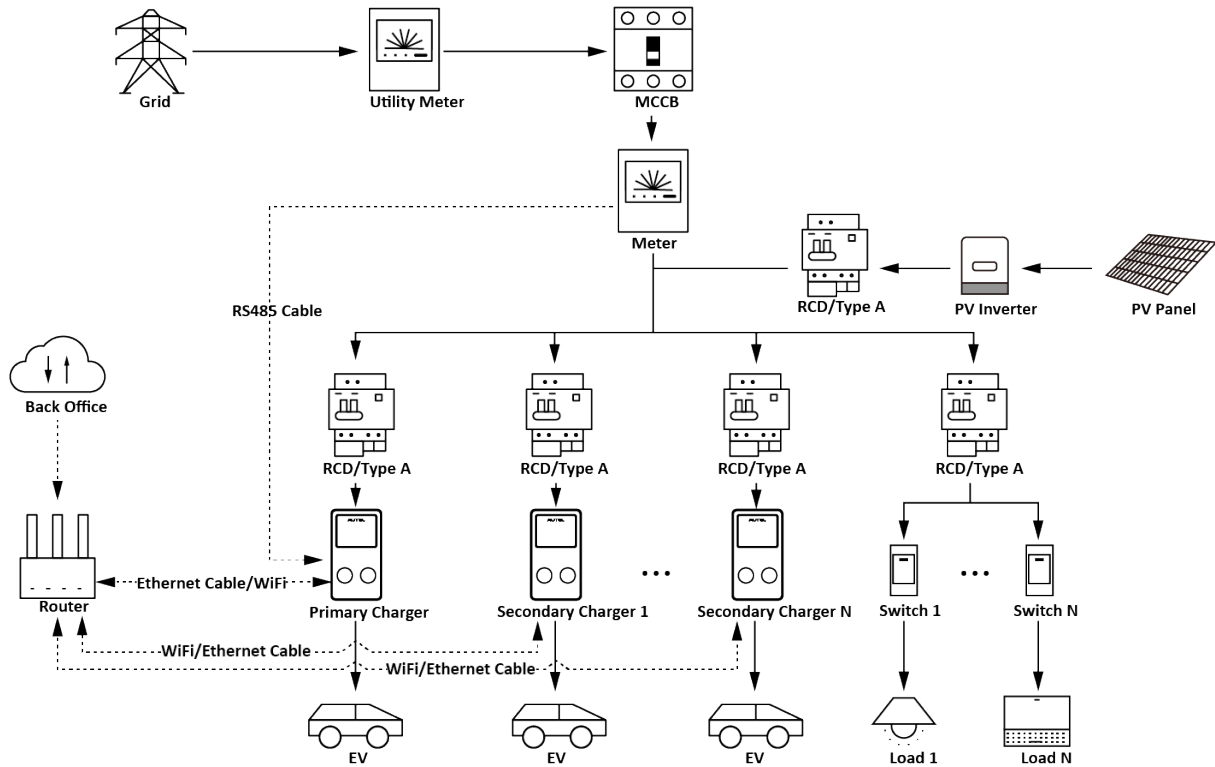

PV Hybrid Mode System Diagram (w/Multiple Chargers)

➤ For AC Ultra + AC Wallbox/AC Compact

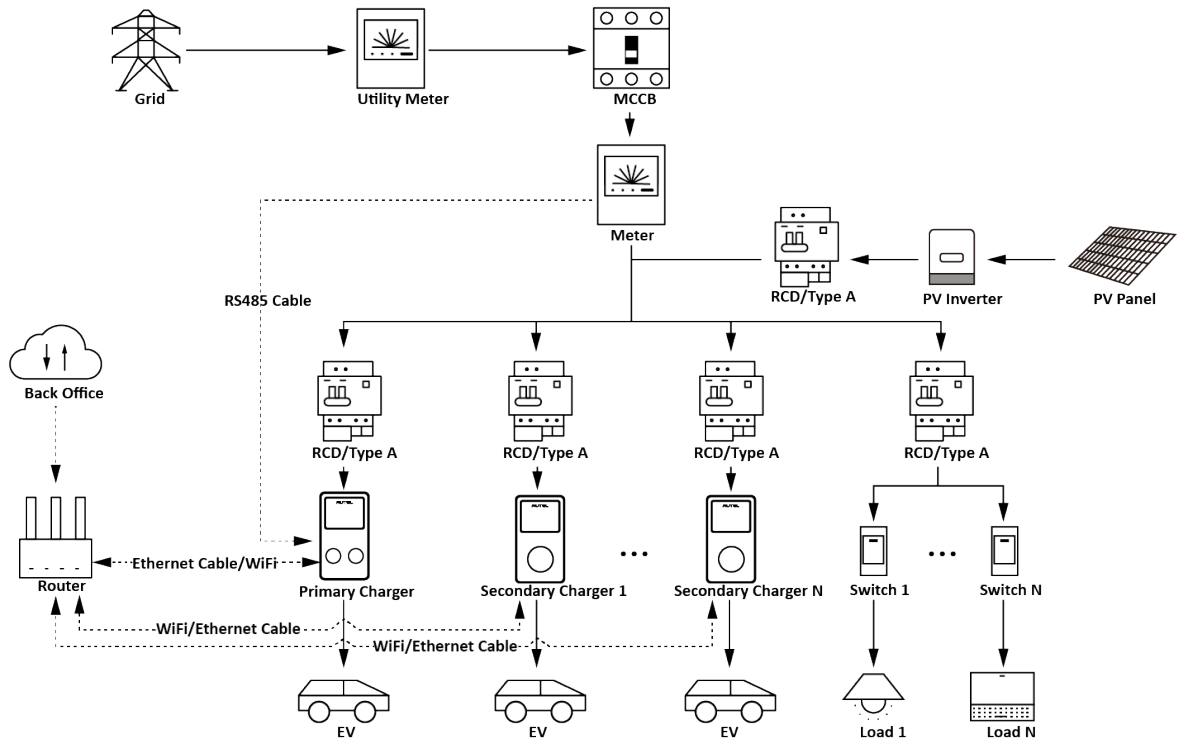

PV Hybrid Mode System Diagram (w/Multiple Chargers)

3.1.2.6 EMS Mode

Integrating EMS with the charger allows the EMS to remotely control the charger using the Modbus TCP protocol. In this mode, all requests are initiated by the EMS, and the charger responds accordingly.

➤ **For AC Wallbox/AC Compact**

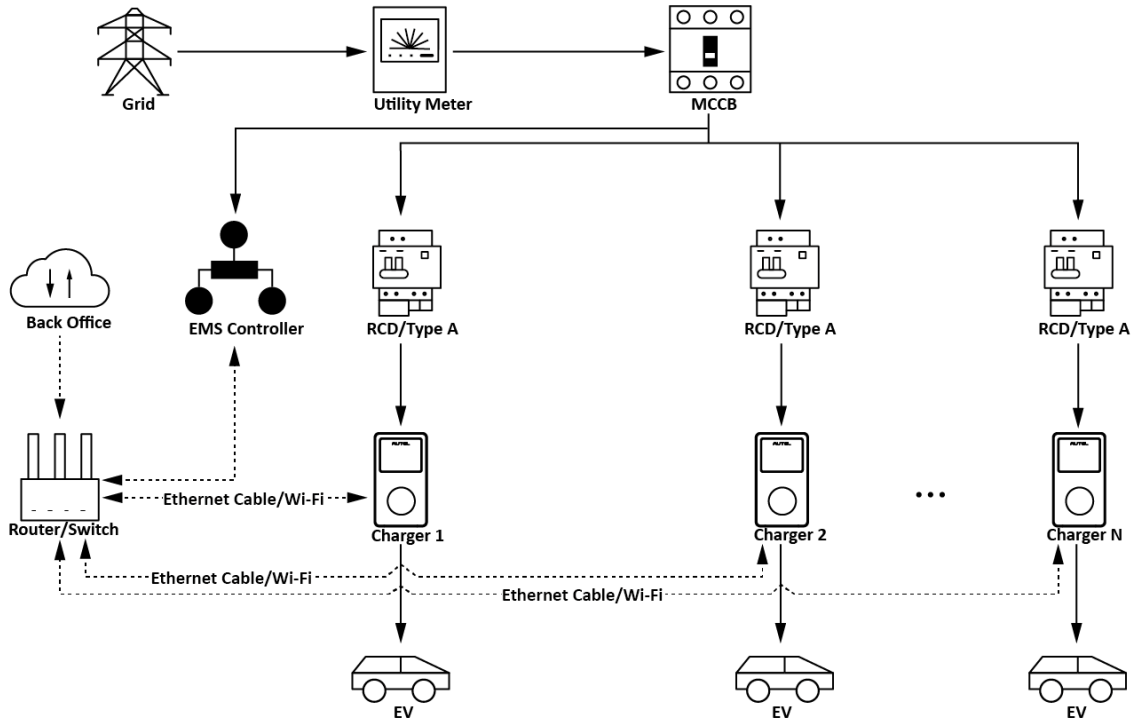

EMS Mode System Diagram

➤ For AC Ultra/DC Compact/DC Fast

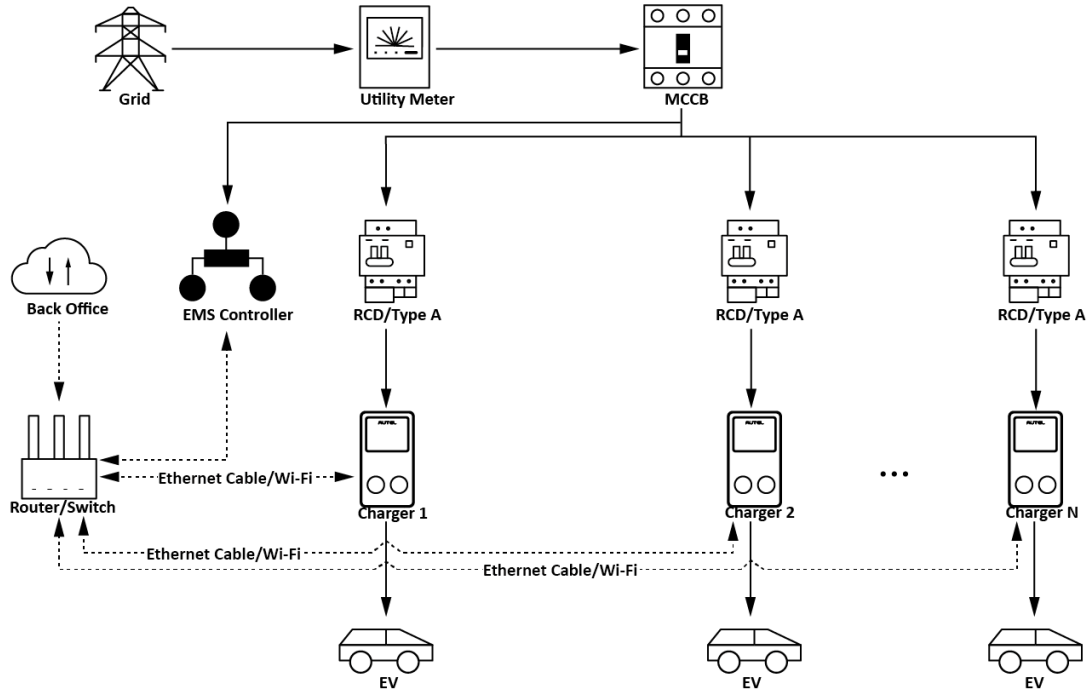

EMS Mode System Diagram

3.2 Wiring Ethernet Cable

Before proceeding with the installation, we assume that you have already installed other devices. Therefore, this guide will only cover the necessary installation steps that follow.

3.2.1 For Single Charger

Follow the steps below to connect the charger to the router using an Ethernet cable.

1. Keep the power turned off during wiring.
2. Plug the Ethernet cable into the RJ45 port at the back of the main unit.
3. Connect the other end of the Ethernet cable to the router.

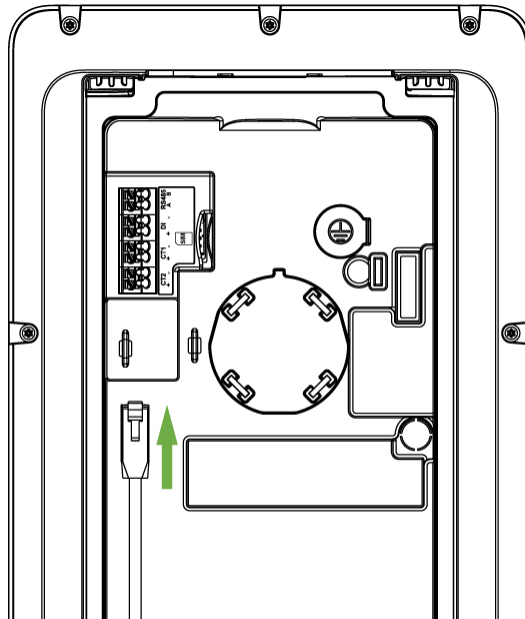

3.2.2 For SmartBox

Follow the steps below to connect the SmartBox to the router using an Ethernet cable and to connect the SmartBox to the SmartSensor using a communication cable (included in the package).

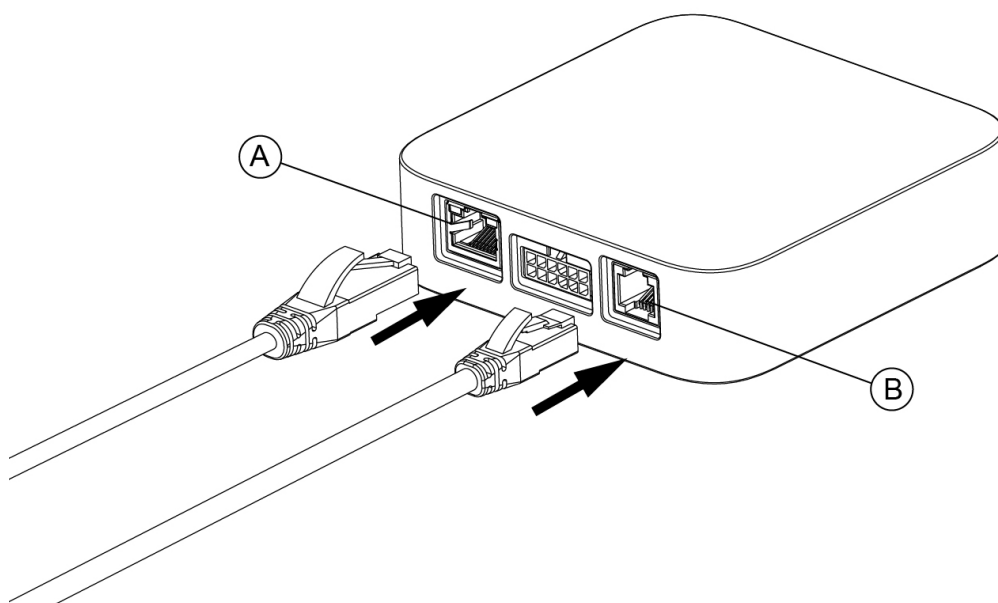

1. Keep the power turned off during wiring.
2. Plug the Ethernet cable into the RJ45 port (port A in the following picture) at the bottom-left of the SmartBox.
3. Plug the communication cable into the RJ12 port (port B in the following picture) at the bottom-right of the SmartBox.
4. Connect the other end of the Ethernet cable to the router.



3.2.3 For AC Wallbox

Both the primary charger and its secondary chargers need to be connected to the same LAN/WLAN:

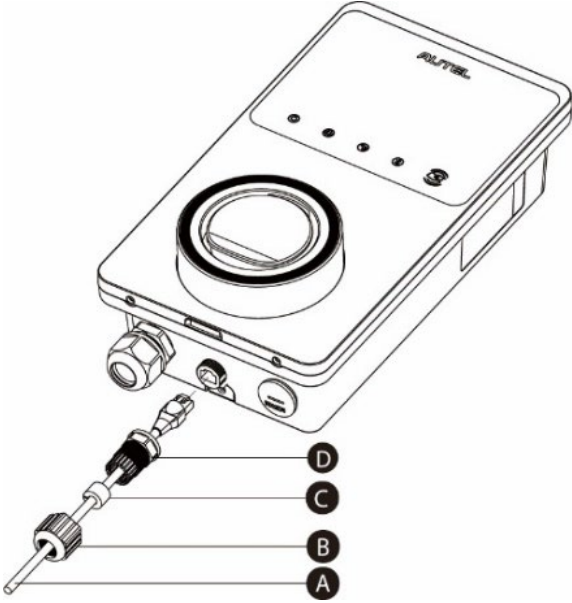
1. The primary charger can establish a LAN/WLAN connection through an Ethernet cable or Wi-Fi (refer to 3.3.3). For the sake of a more stable network, we recommend using an Ethernet cable to establish this connection.

<ol style="list-style-type: none">1. Keep the power turned off during wiring.2. Insert one end of the Ethernet cable with RJ45 plug into the RJ45 port on the charger.<ul style="list-style-type: none">• Put the Ethernet cable with RJ45 plug (A) through the nut (B) and the waterproof cap (D). (Leave some space between them.)• Connect the sealing ring (C) via its opening to the Ethernet cable and insert it into the waterproof cap.• Screw the nut into the waterproof cap and make sure they are securely fastened.	
<ol style="list-style-type: none"><ul style="list-style-type: none">• Insert the RJ45 plug of the Ethernet cable into the RJ45 port (E) on the bottom of the charger.3. Insert the other end of the Ethernet cable with RJ45 plug into the RJ45 port on the router.	

2. Secondary chargers can connect to the LAN/WLAN via either Ethernet cables or Wi-Fi, and the instructions are the same as that of the primary charger.

3.2.4 For AC Compact

Follow the steps below to connect the charger to the router using an Ethernet cable.

1. Keep the power turned off during wiring.
2. Connect the Ethernet cable to the port inside the main unit.
3. Connect the other end of the Ethernet cable to the router.

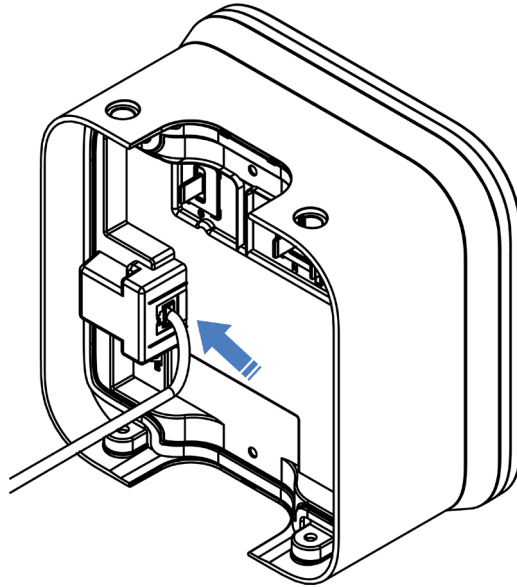

3.2.5 For AC Ultra

Follow the steps below to connect the charger to the router using an Ethernet cable.

1. Keep the power turned off during wiring.
2. Insert the Ethernet cable with the RJ45 plug through either of the bottom data cable entry.
3. Plug the Ethernet cable into either of the RJ45 port as shown.
4. Connect the other end of the Ethernet cable to the router.

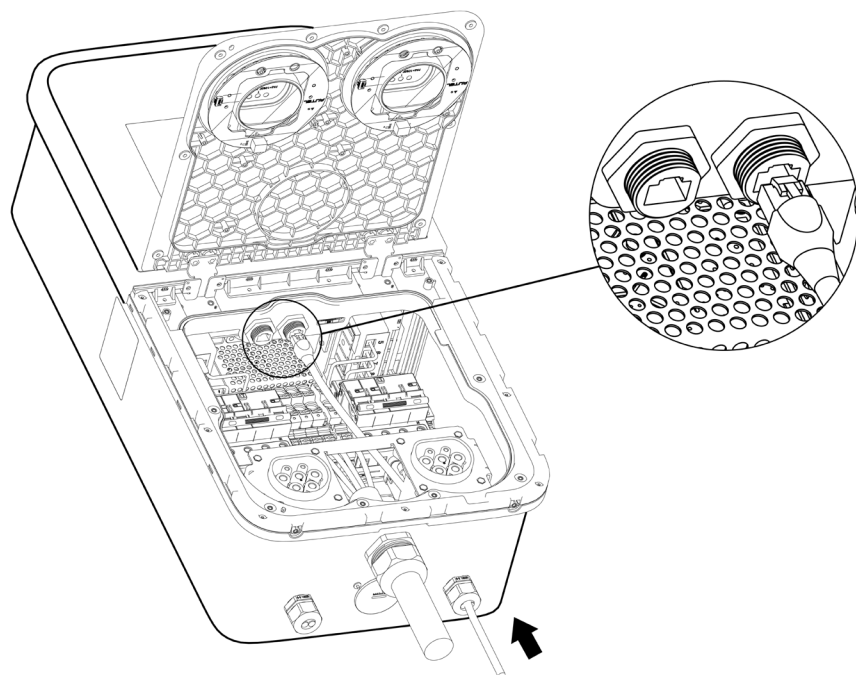

3.2.6 For DC Compact

Follow the steps below to connect the charger to the router using an Ethernet cable.

1. Keep the power turned off during wiring.
2. Loosen the cable gland (A).
3. Put the Ethernet cable through the Ethernet cable port at the bottom of the charger.
4. Plug the Ethernet cable into the RJ45 port.
5. Tighten the cable gland (A).
6. Connect the other end of the Ethernet cable to the router.

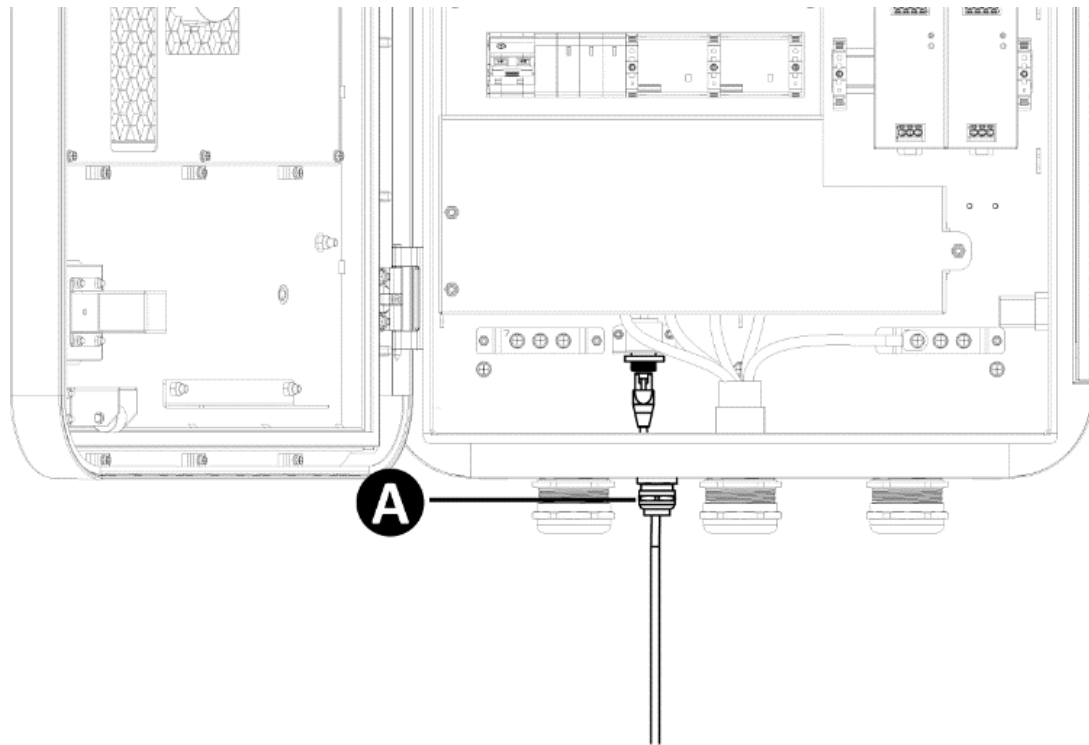

NOTE

For trolley-mounted MaxiCharger, Wi-Fi is preferred to access the Internet for movability.

3.2.7 For DC Fast

Follow the steps below to connect the charger to the router using an Ethernet cable.

1. Keep the power turned off during wiring.
2. Connect one end of the Ethernet cable to the RJ45 port and the other end to the router.

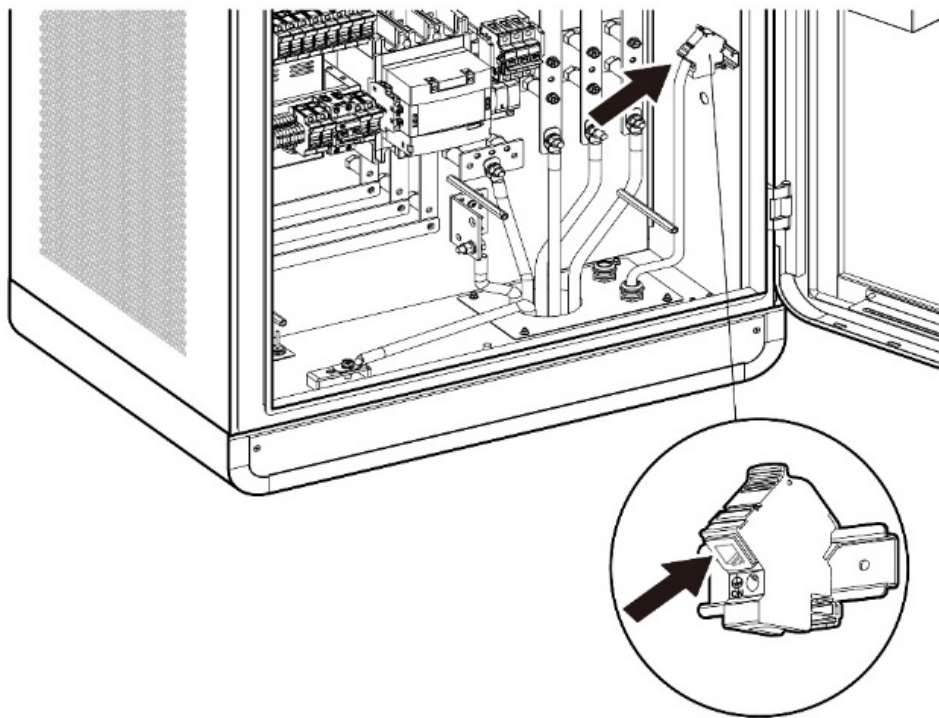

3.3 Wi-Fi Connection

3.3.1 For Single Charger

Refer to chapter “Activation Task” in *MaxiCharger Single Charger_Commissioning Guide_CE*.

3.3.2 For SmartBox

Refer to chapter “Configure” in *SmartBox Kit_Installer and User Guide*.

3.3.3 For AC Wallbox/AC Compact

1. **Download** the Autel ChargeAPP.

NOTE

Make sure all Autel AC MaxiChargers and the Autel ChargeAPP are running the latest software versions.

2. **Log in** to your Autel ChargeAPP using your account and password, or register if you don't yet have an Autel Charge account.

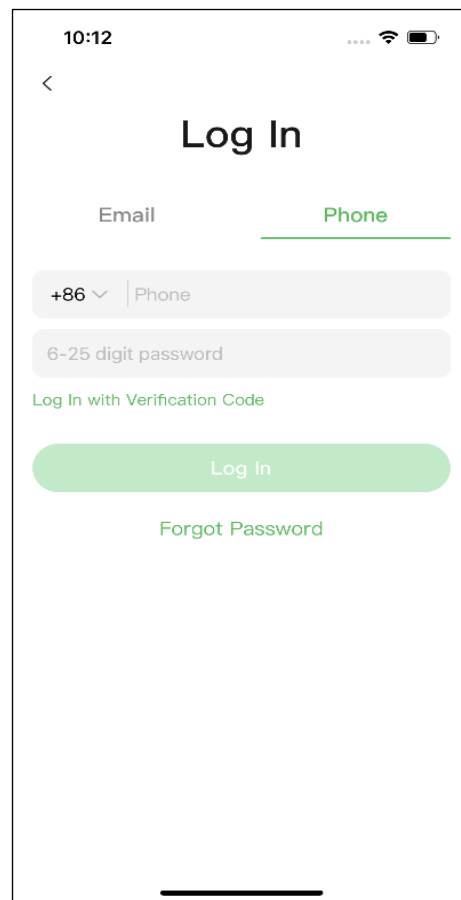
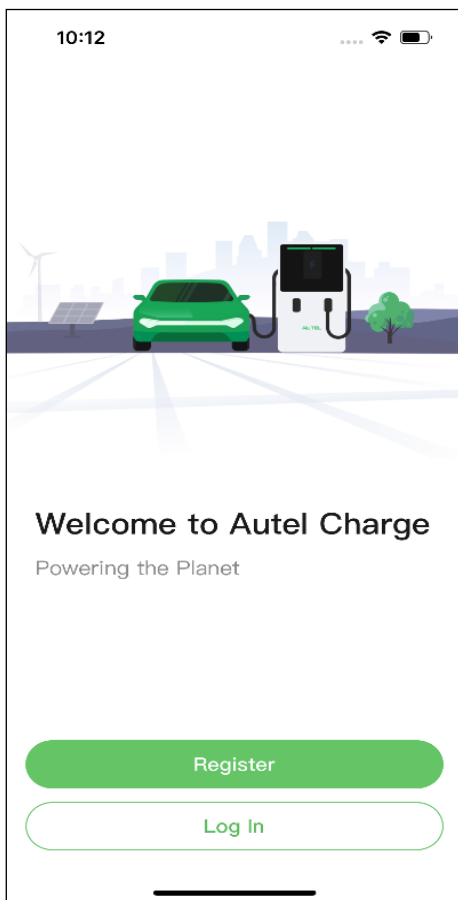

3. **Add a charger.** After successfully logging in, tap **Add** to continue. Scan the QR code on the Quick Reference Guide to acquire the serial number and PIN of the charger, or tap **Enter Terminal Number** to manually enter the serial number and PIN. Tap **Link** after confirmation.

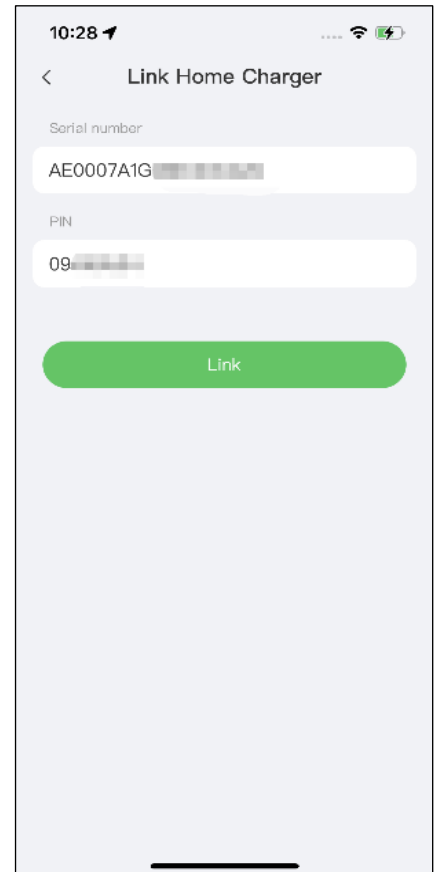
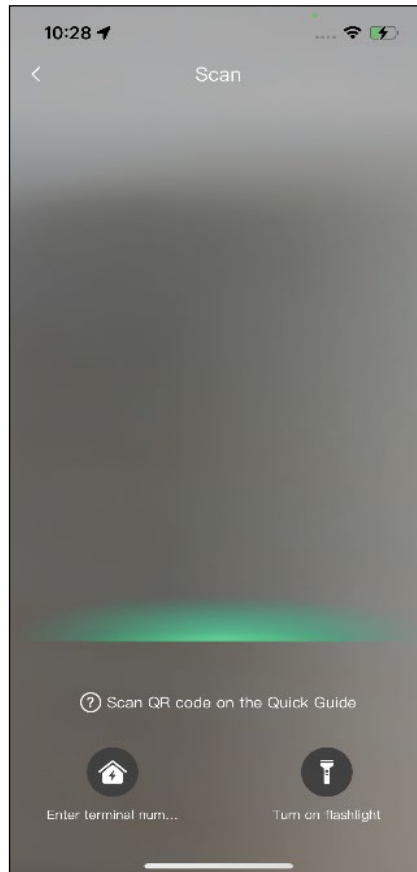
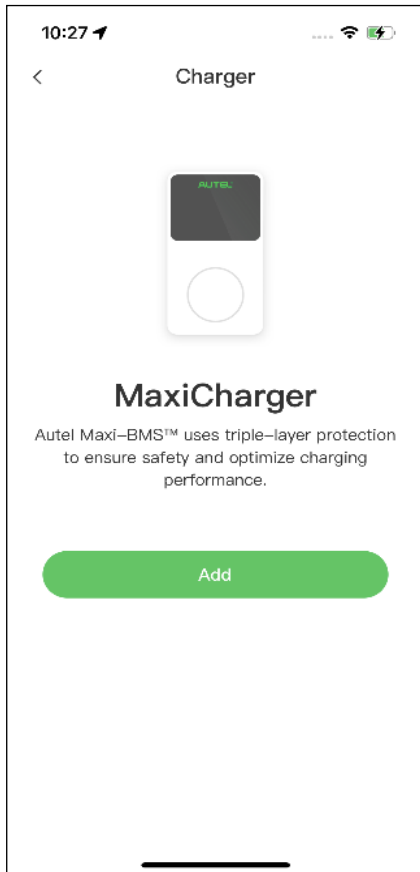

4. **Establish a communication between the charger and the Autel ChargeAPP.** After adding the charger, tap **Connect via Bluetooth** to establish a communication, then configure Wi-Fi for the charger. Tap **Completed** on the Charge Settings screen to finish Wi-Fi connection.

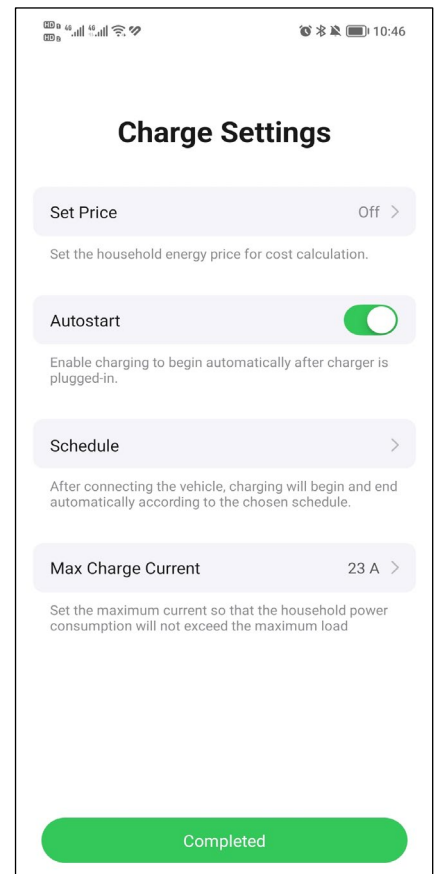
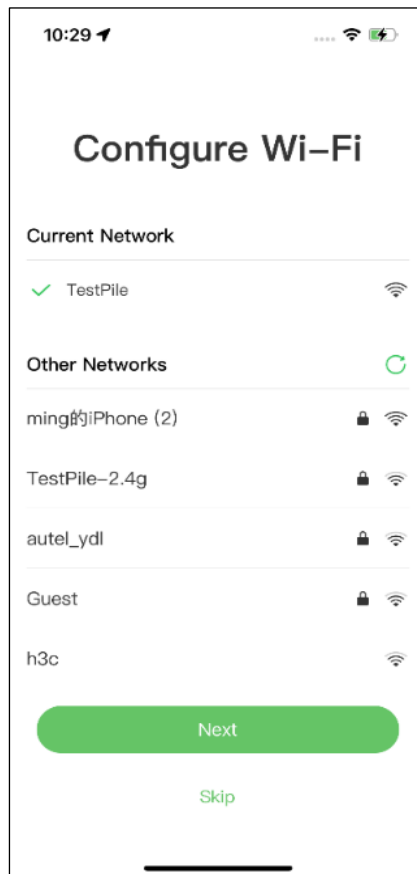
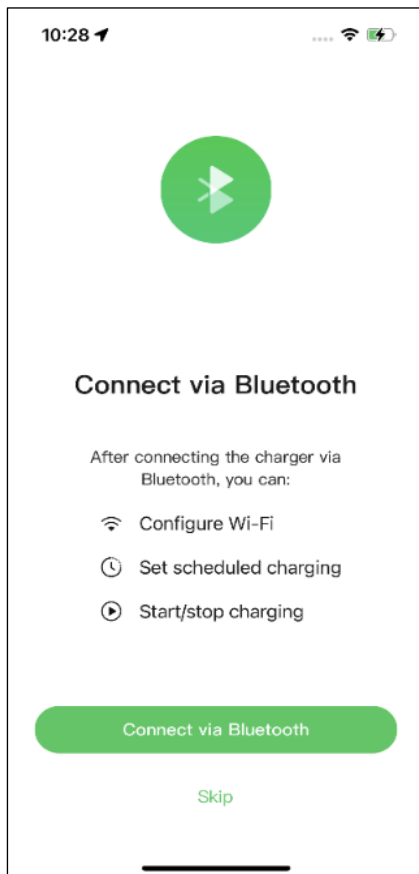

NOTE

Bluetooth can only be connected to one charger at a time. Switching the operation to another charger will disconnect the Bluetooth connection with the existing charger and connect it to a new charger.

All chargers added must be on the same Wi-Fi network.

3.3.4 For AC Ultra/DC Compact/DC Fast

1. On the Standby screen, tap the “currency (\$)” icon on the lower-left corner to enter the Cost Details screen.

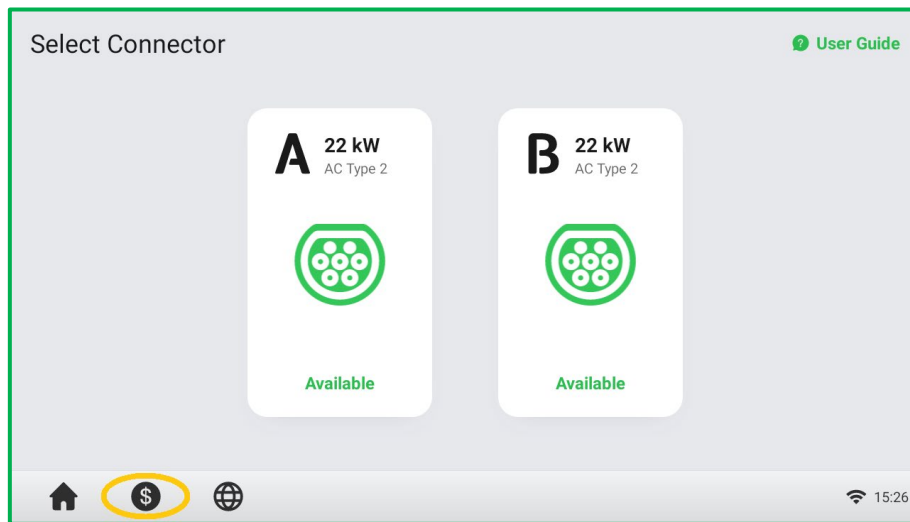

2. On the Cost Details screen, **double tap** the upper-left corner to proceed.

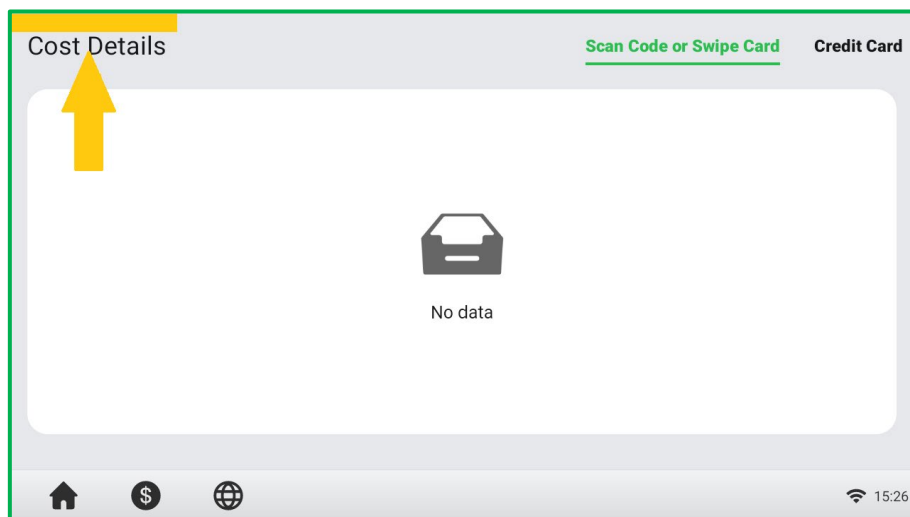

3. Select **Device Maintenance** on the screen.

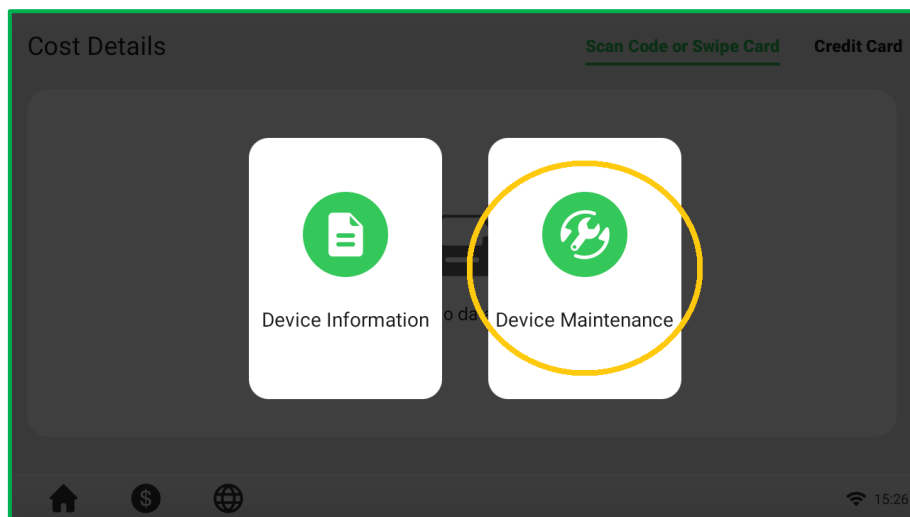

4. A password prompt will appear. Enter **the last 6 characters of the product serial number** to continue, which can be found on the product label. For example, if the product serial number is DE0090B1GNBC00029P, the password is 00029P (The letter “P” is capitalized). If that doesn’t work, try using 1234 as the password.

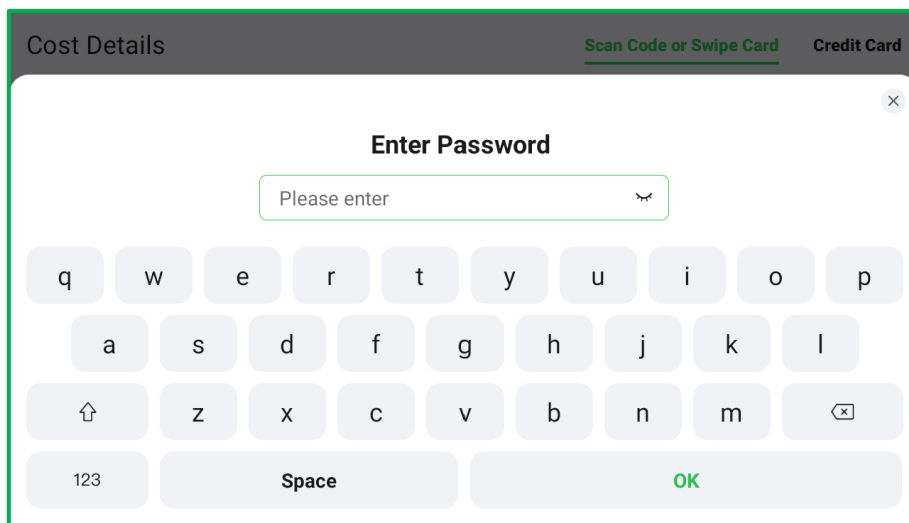

5. On the Device Maintenance screen, click on **Select Network**.

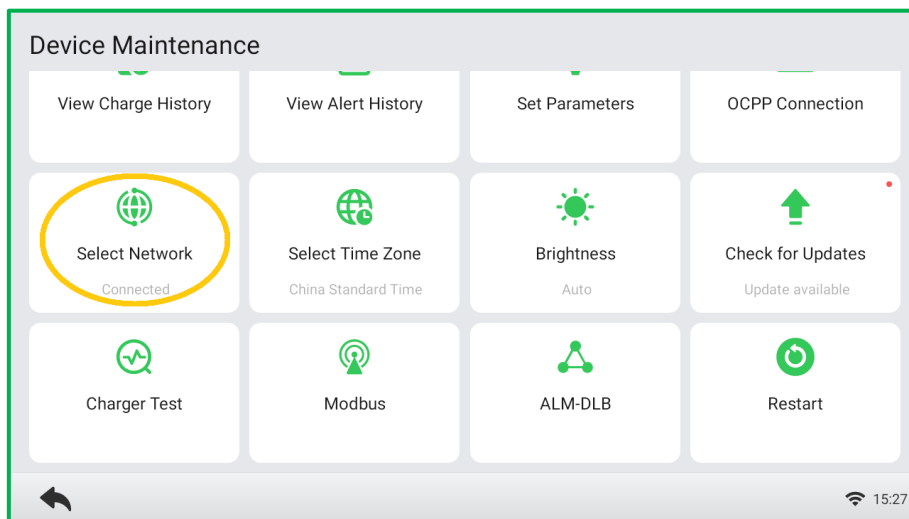

6. Enable Wi-Fi as shown below. Select the Wi-Fi needed and enter the password to establish a WLAN connection.

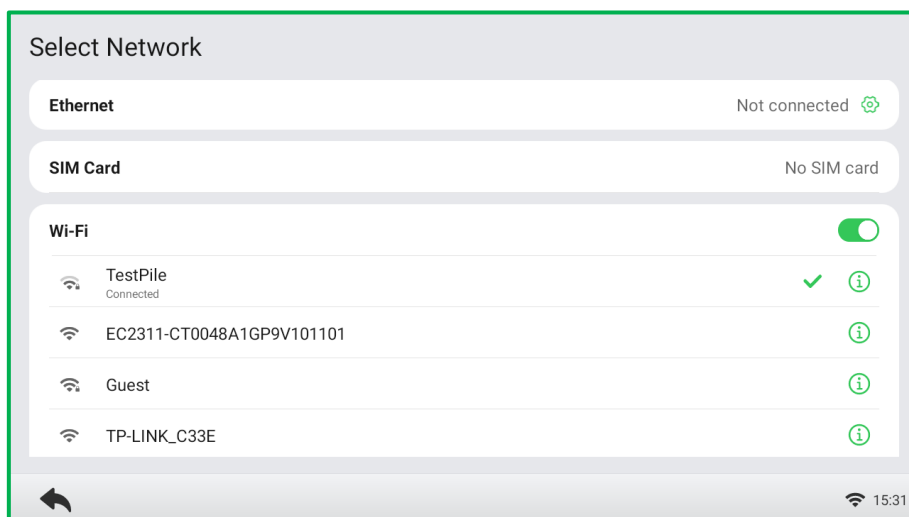

7. To avoid a change in IP address after powering off or restarting the charger:

- 1) Tap the icon “i” to the right of the selected Wi-Fi and choose **Set**.
- 2) Click “>” to the right of the IP Settings and select **Static**.
- 3) Configure the **Default Gateway** manually.
- 4) Click the **Save** button to save the setup.

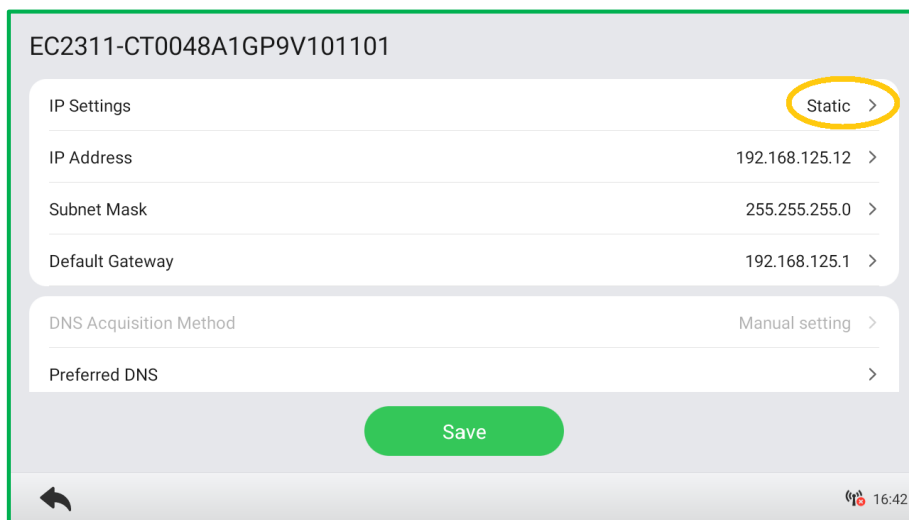
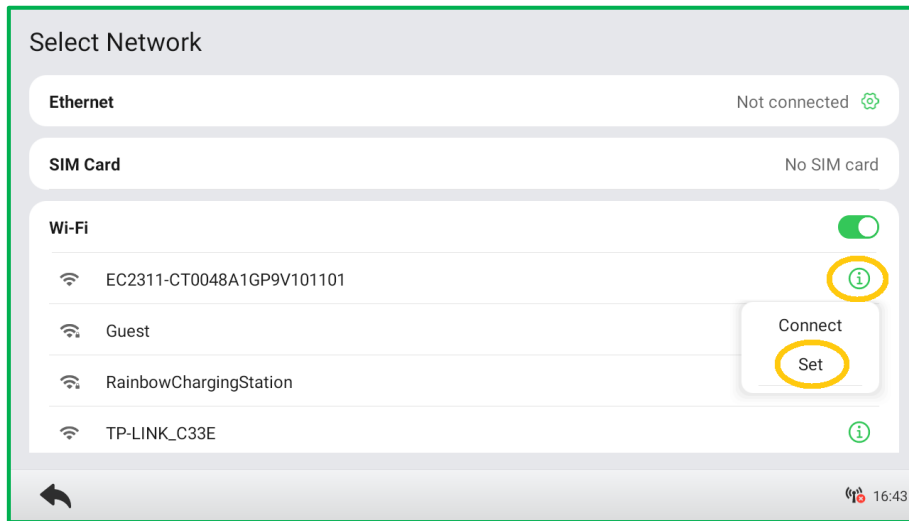

3.4 Wiring RS-485 Cable

An RS-485 cable is required for establishing a communication between the primary charger and the meter.

3.4.1 For Single Charger

Follow the steps below to connect the charger to the Eastron meter or the SmartSensor using an RS-485 cable.

1. Use a flathead screwdriver to press and hold the button above the RS-485 port.
2. Connect the RS-485-A wire to the port marked "A" and the RS-485-B wire to the port marked "B".

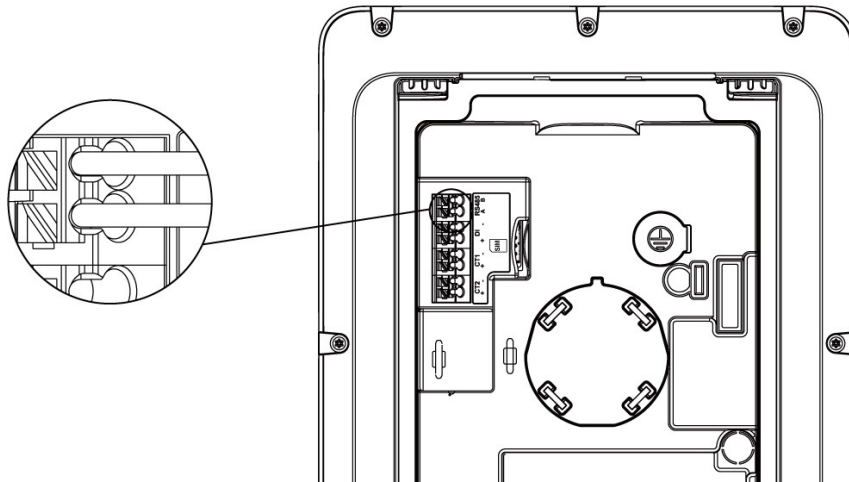

NOTE

Always keep the power turned off during wiring.

To establish a communication between the primary charger and the Eastron meter, the following settings of the Eastron meter should be completed:

- ◆ **Modbus Address:** 001
- ◆ **Baud Rate:** 9600
- ◆ **Parity Bit:** NONE

3.4.2 For AC Wallbox

To save time in purchasing an appropriate energy meter, the recommended energy meters are listed below, which can be purchased from local distributors.

Phase	Current Range	Part	Meter Type (Recommended)	CT Type (Recommended)
Single-phase	≤ 100 A (for EU market)	Meter	SDM230-Modbus V1	/
	≤ 100 A (for UK market)	Meter	SDM230-Modbus V2	/
	≤ 100 A	Meter + CT	SDM120CTM	ESCT-TA16 100A/100mA
Three-phase	≤ 100 A	Meter	SDM630-Modbus V2	/
	> 100 A	Meter + CT	SDM630MCT V2	ESCT-T24 250A/5A

After the meter is properly installed and connected to upstream MCB/RCBO, wire an RS-485 cable between the charger and meter.

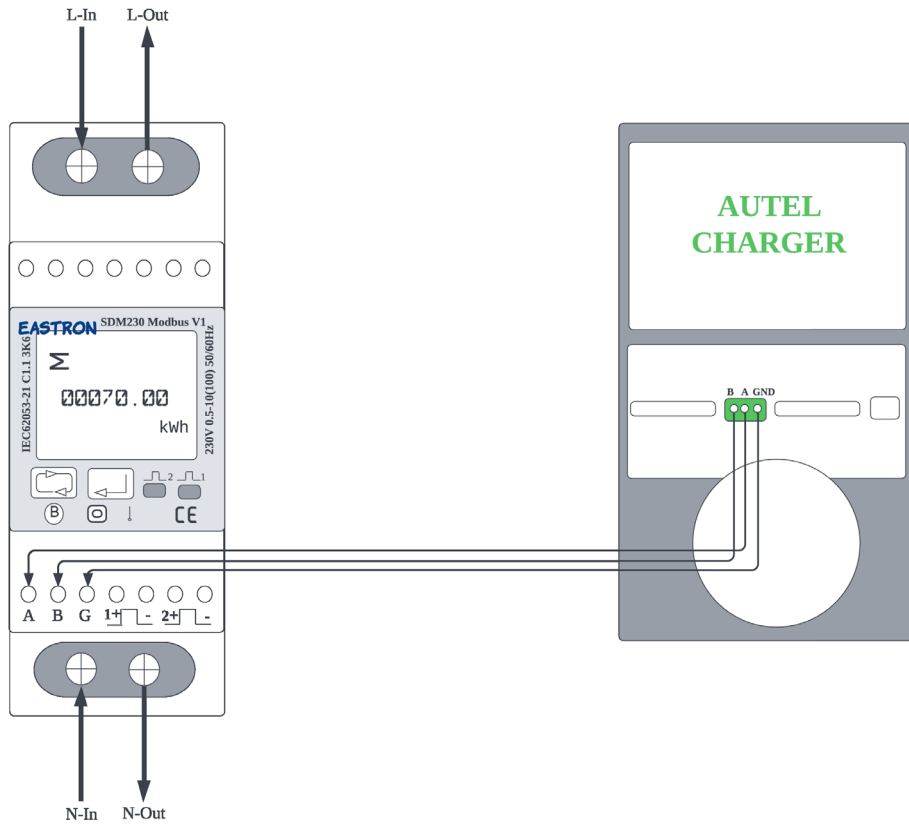

SDM230-Modbus V1 Energy Meter and Autel Charger Wiring Diagram

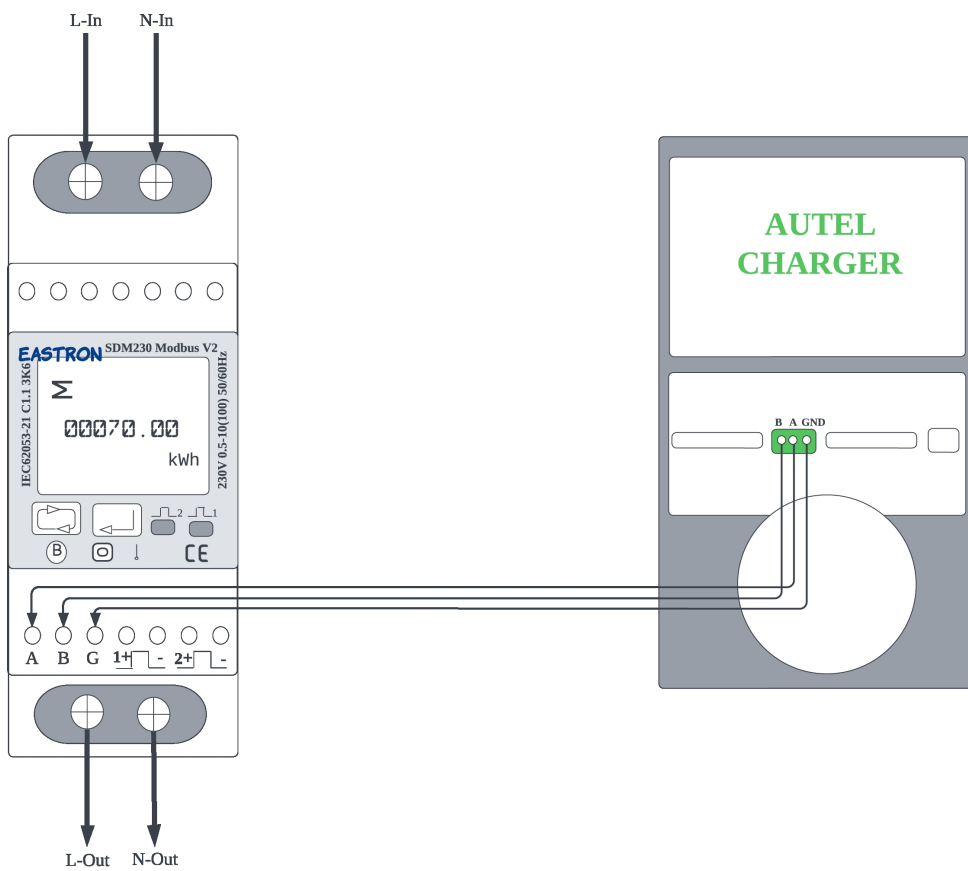

SDM230-Modbus V2 Energy Meter and Autel Charger Wiring Diagram

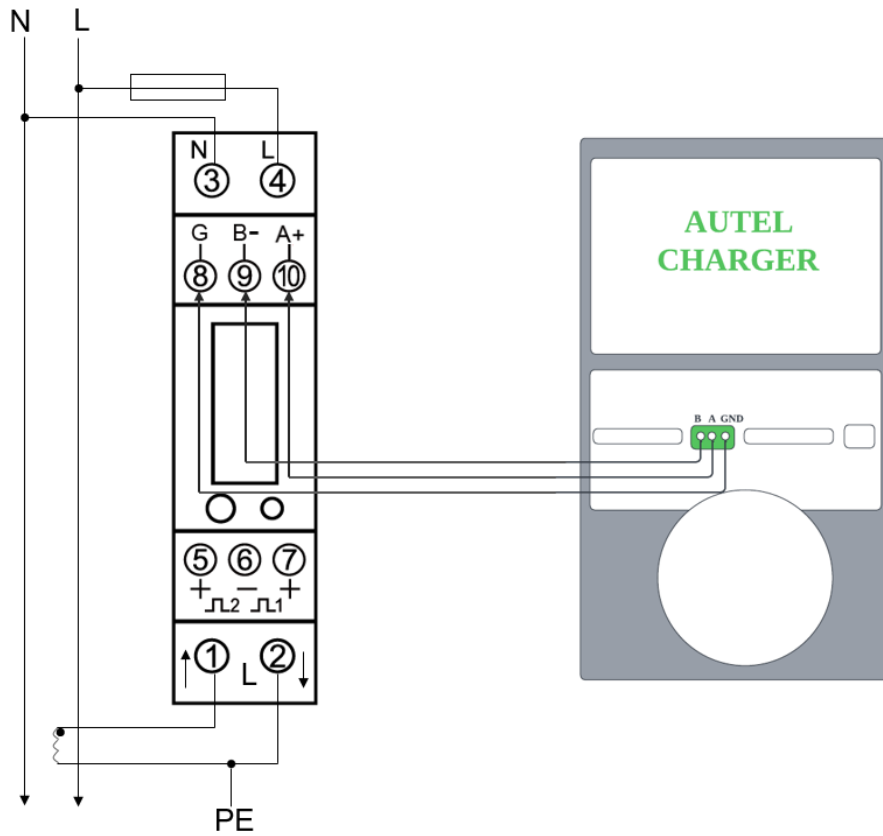

SDM120CTM Energy Meter and Autel Charger Wiring Diagram

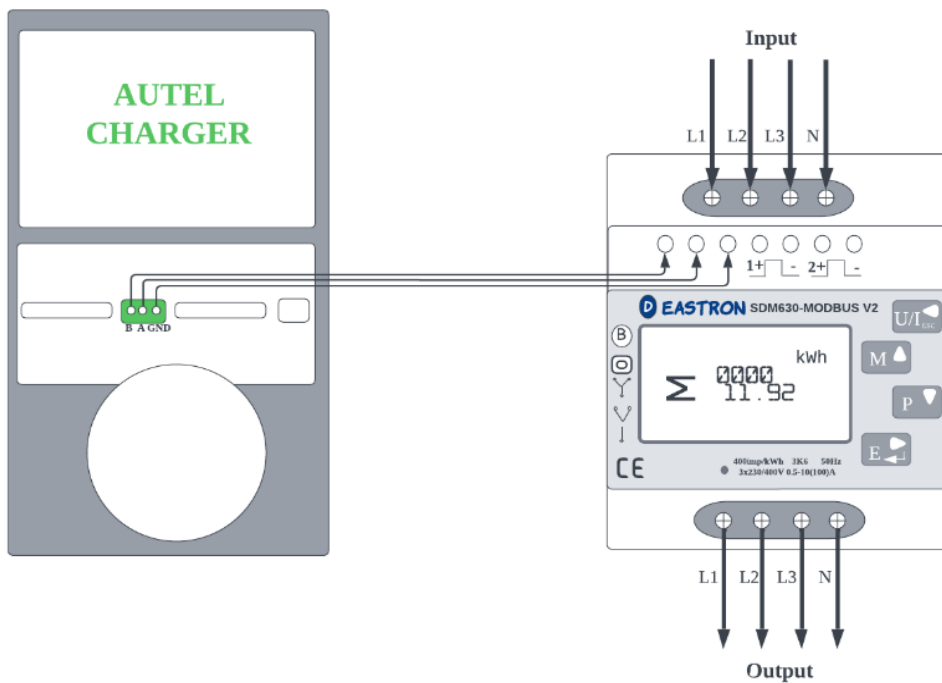

SDM630-Modbus V2 Energy Meter and Autel Charger Wiring Diagram

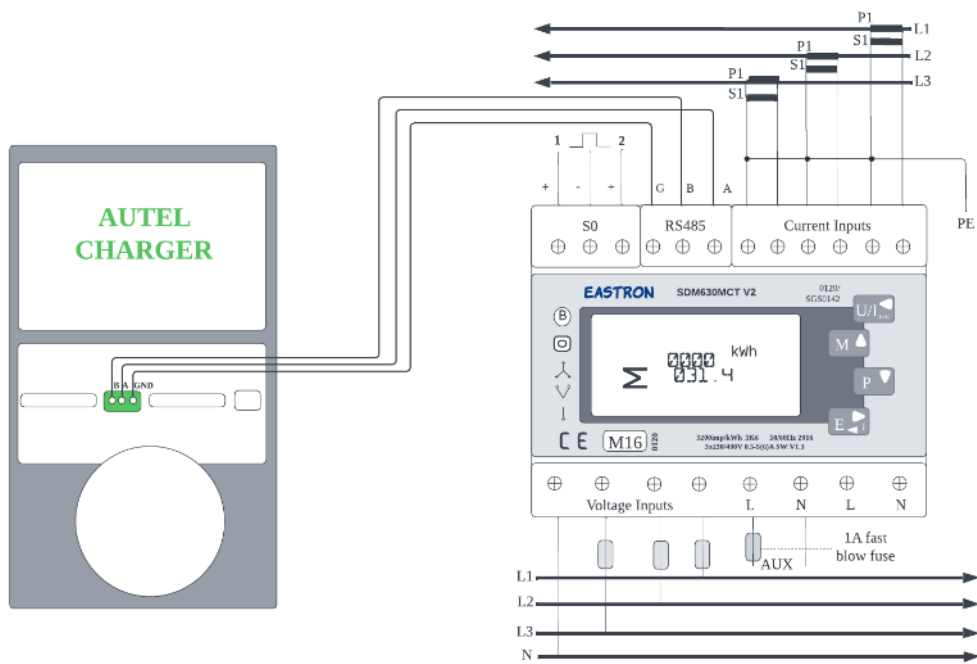

SDM630MCT V2 Energy Meter and Autel Charger Wiring Diagram

NOTE

Always keep the power turned off during wiring.

Ground wiring is not necessary in many cases. Determine whether to ground according to the local regulations. The above diagrams are presented in the form of grounding.

The CT sensors should be grounded to local PE due to the need for surge current protection. In order for the meter to measure data accurately, it needs to be configured correctly. Please refer to the meter's user manual for configuration instructions.

To establish a communication between the primary charger and the Eastron meter, the following settings of the Eastron meter should be completed:

- ◆ **Modbus Address:** 001
- ◆ **Baud Rate:** 9600
- ◆ **Parity Bit:** NONE

3.4.3 For AC Compact

To save time in purchasing an appropriate energy meter, the recommended energy meters are listed below, which can be purchased from local distributors.

Phase	Current Range	Part	Meter Type (Recommended)	CT Type (Recommended)
Single-phase	≤ 100 A (for EU market)	Meter	SDM230-Modbus V1	/
	≤ 100 A (for UK market)	Meter	SDM230-Modbus V2	/
	≤ 100 A	Meter + CT	SDM120CTM	ESCT-TA16 100A/100mA
Three-phase	≤ 100 A	Meter	SDM630-Modbus V2	/
	> 100 A	Meter + CT	SDM630MCT V2	ESCT-T24 250A/5A

After the meter is properly installed and connected to upstream MCB/RCBO, wire an RS-485 cable between the charger and meter.

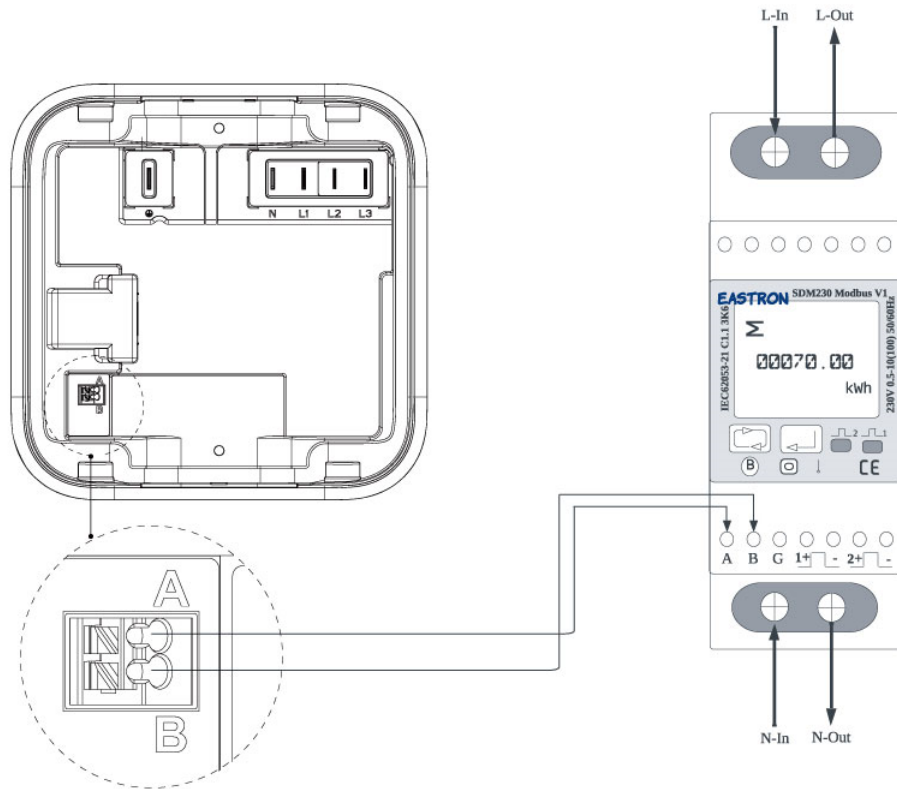

SDM230-Modbus V1 Energy Meter and Autel Charger Wiring Diagram

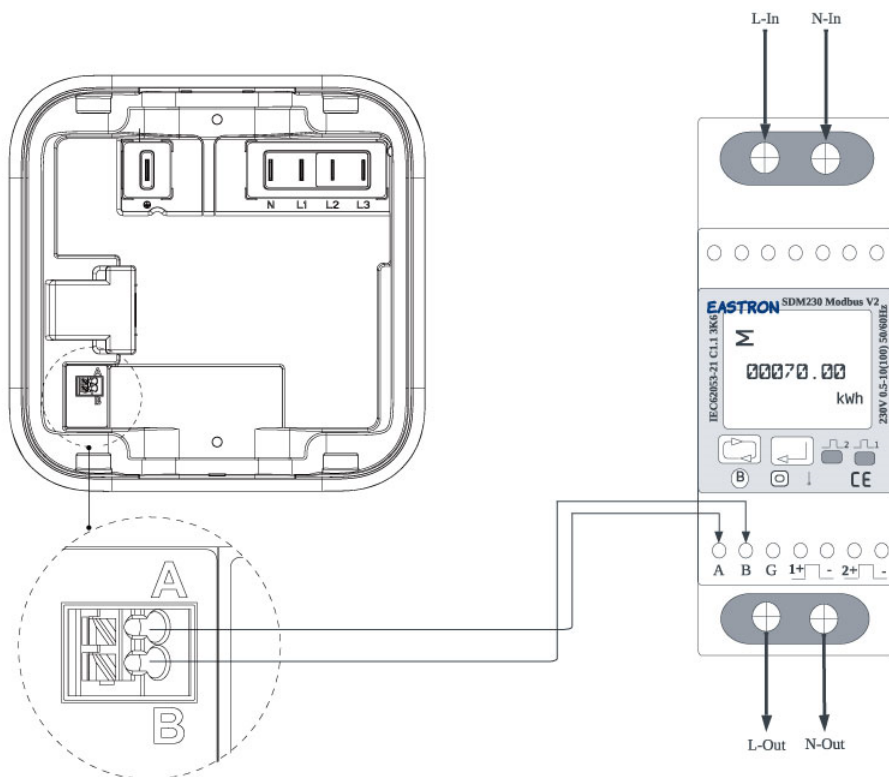

SDM230-Modbus V2 Energy Meter and Autel Charger Wiring Diagram

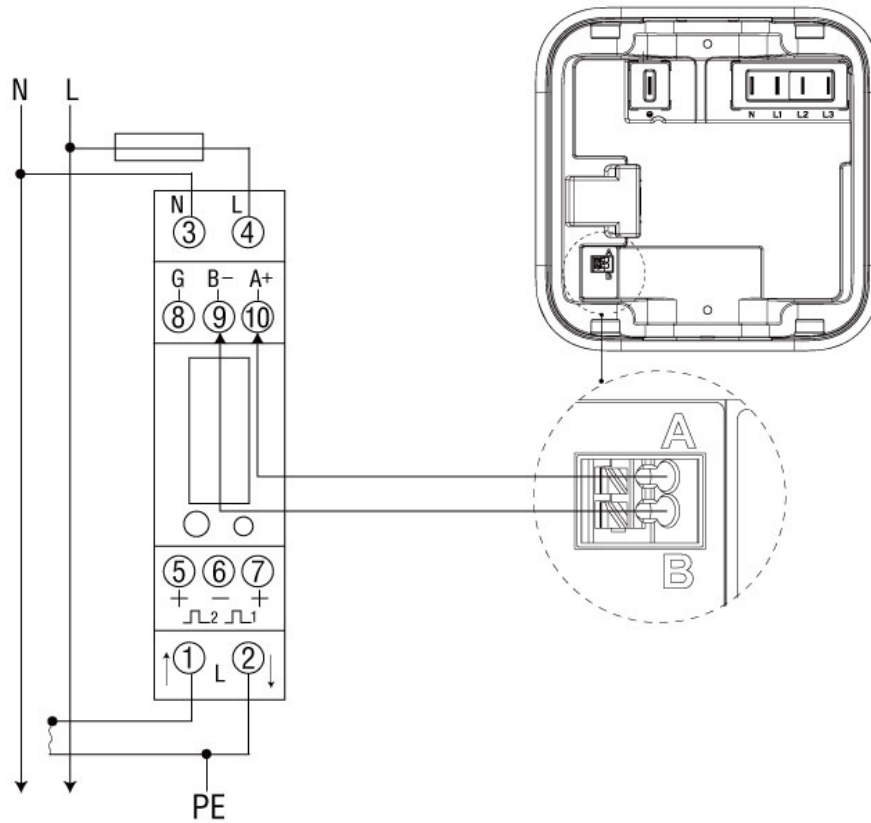

SDM120CTM Energy Meter and Autel Charger Wiring Diagram

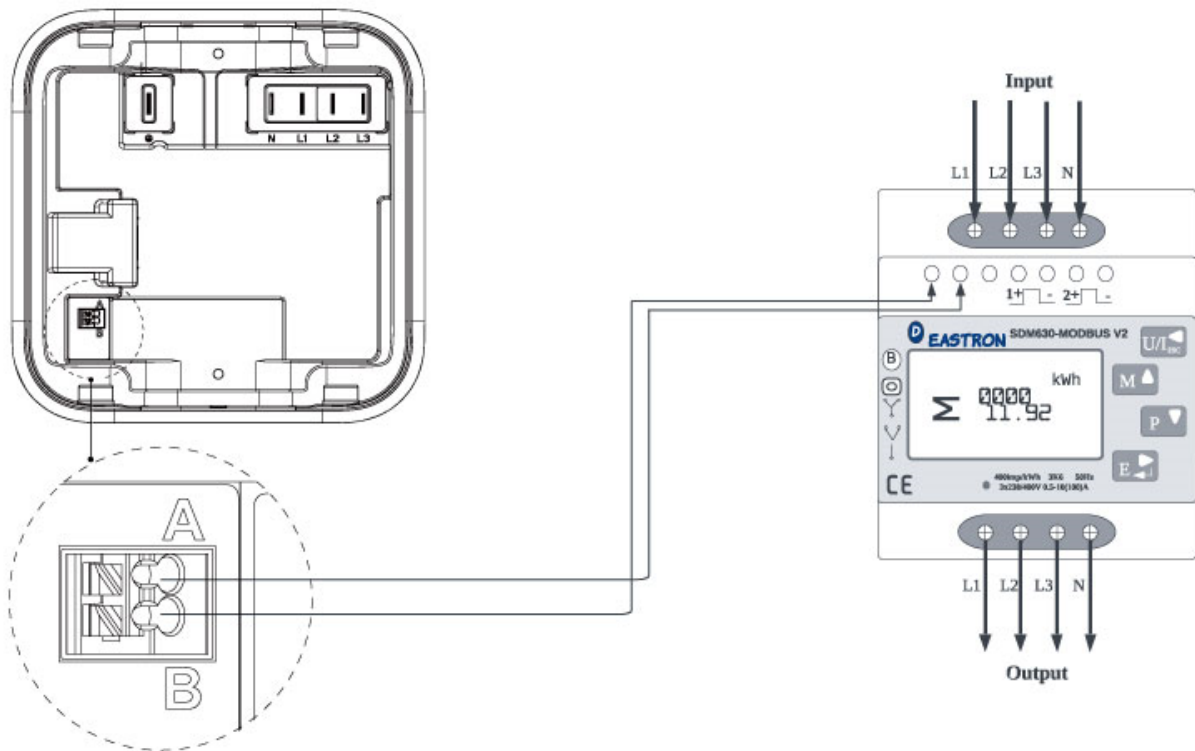

SDM630-Modbus V2 Energy Meter and Autel Charger Wiring Diagram

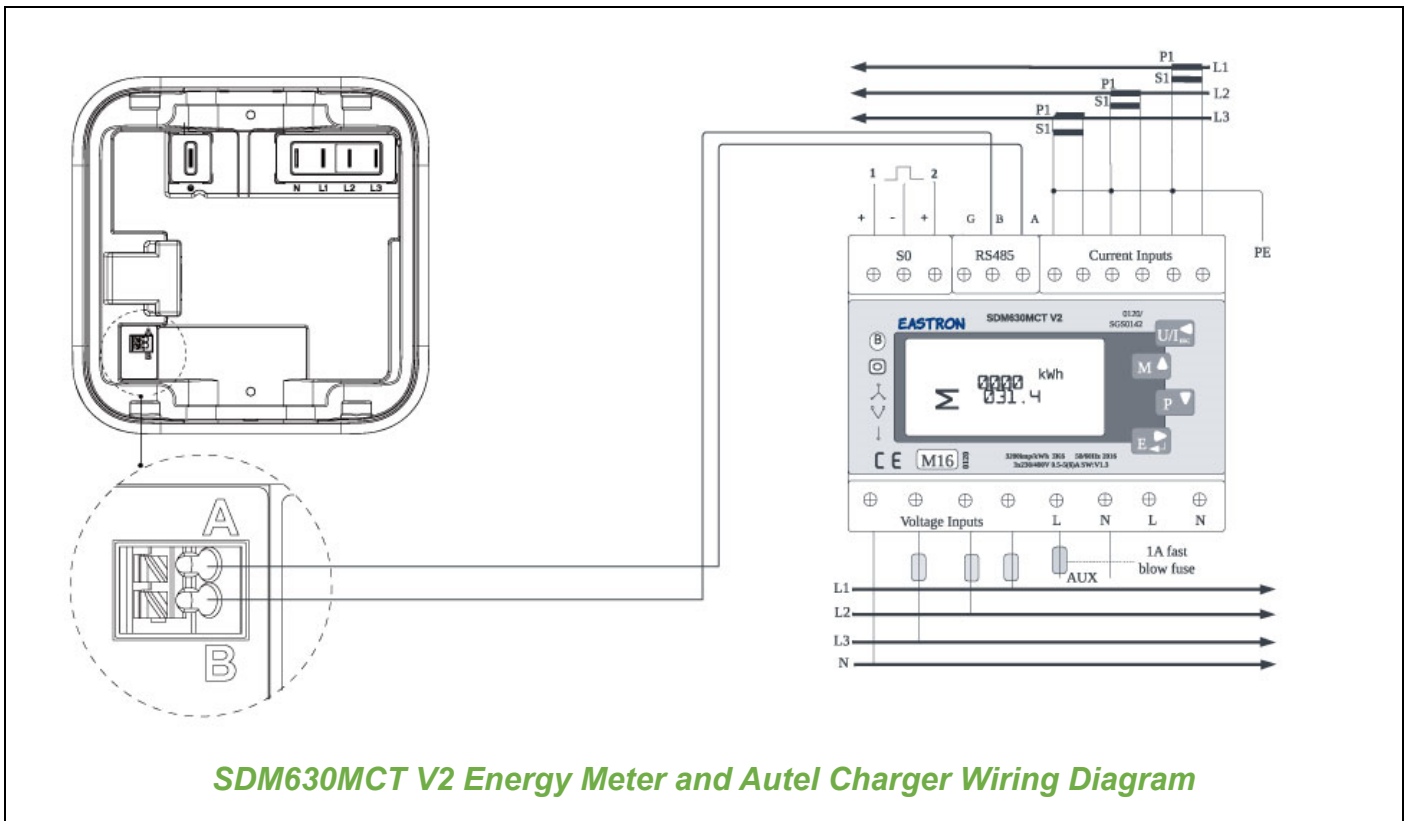

NOTE
 Always keep the power turned off during wiring.

To establish a communication between the primary charger and the Eastron meter, the following settings of the Eastron meter should be completed:

- ◆ **Modbus Address:** 001
- ◆ **Baud Rate:** 9600
- ◆ **Parity Bit:** NONE

3.4.4 For AC Ultra

To save time in purchasing an appropriate energy meter, the recommended energy meters are listed below, which can be purchased from local distributors.

Phase	Current Range	Part	Meter Type (Recommended)	CT Type (Recommended)
Three-phase	≤ 100 A	Meter	SDM630-Modbus V2	/
	> 100 A	Meter + CT	SDM630MCT V2	ESCT-T24 250A/5A

After the meter is properly installed and connected to upstream MCB/RCBO, wire an RS-485 cable between the charger and meter.

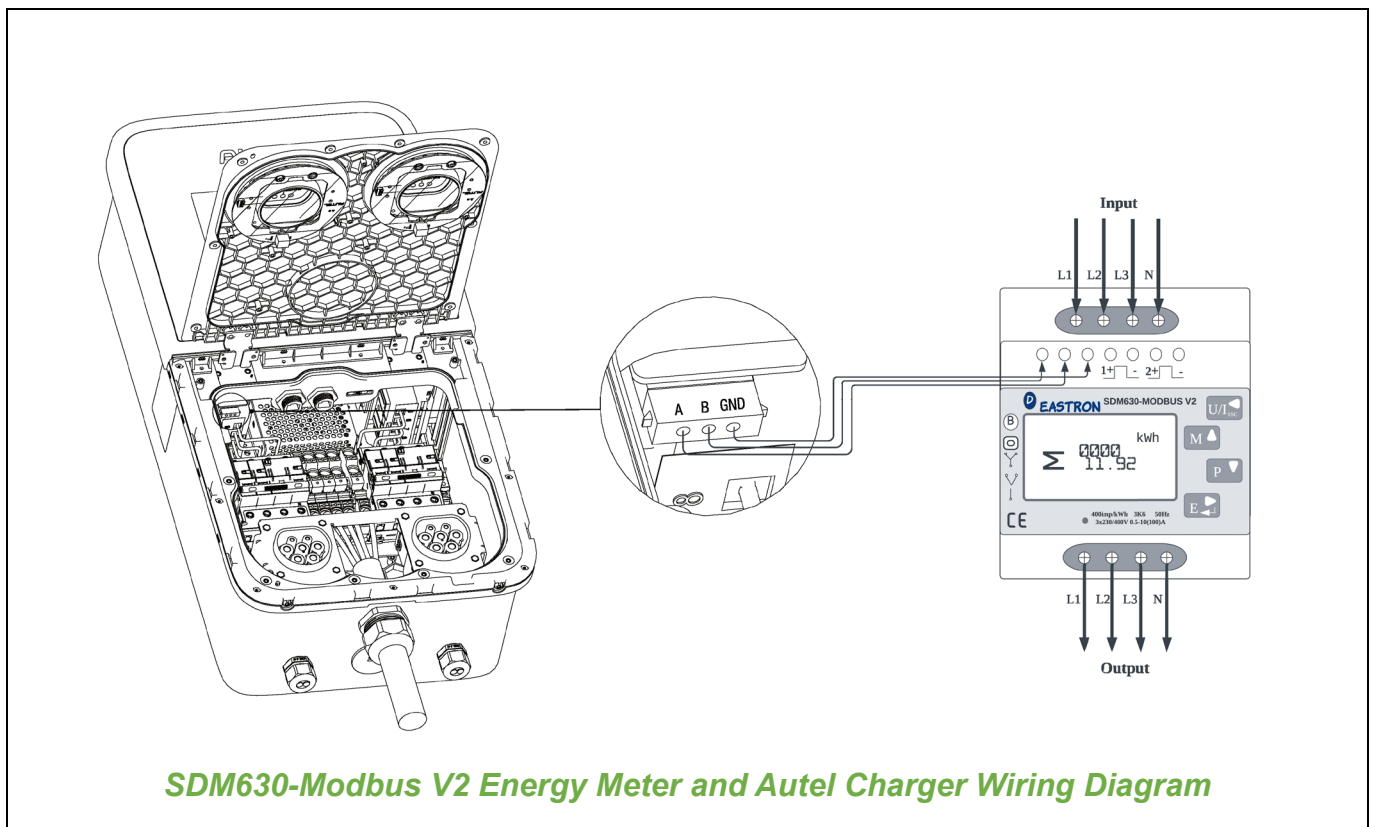

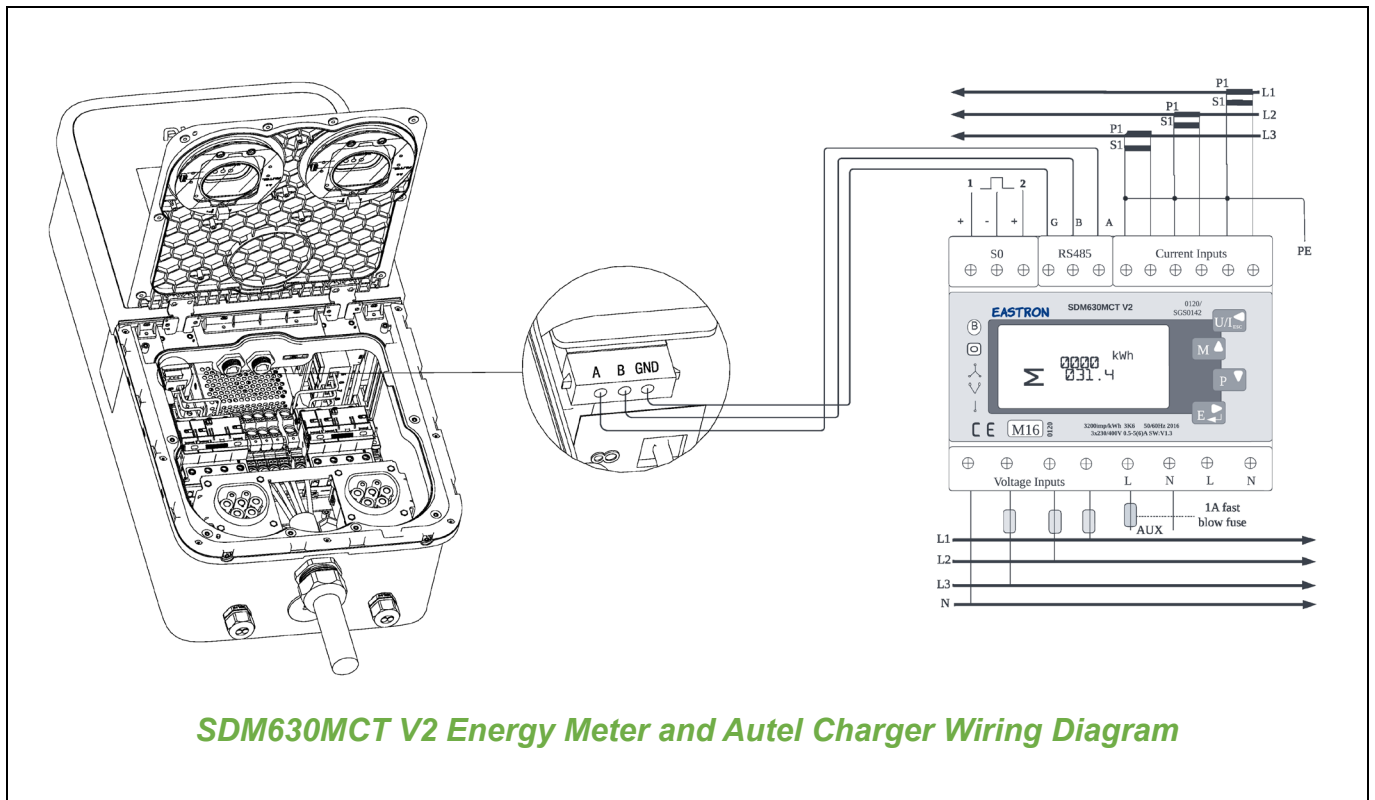

NOTE
Always keep the power turned off during wiring.

To establish a communication between the primary charger and the meter, the following settings of the meter should be completed:

- ◆ **Modbus Address:** 003
- ◆ **Baud Rate:** 9600
- ◆ **Parity Bit:** EVEN
- ◆ **Stop Bit:** 1





Entering Set-up Menu

Power up the meter. All the display segments will light up on the screen of the meter. The Set-up Menu is password-protected, so password verification is required before proceeding. The default password is 1000.

➤ **To enter the correct password**

1. Long press the  button for 3 seconds to enter the Password screen — the first digit will be flashing.



2. Short press the  button or the  button to set the digit to the required number. And next, short press the  button to move right. The next digit will be flashing. Repeat the procedures to set the remaining digits.
3. When the password displays 1000, long press the  button to confirm your setting.



4. If the password is correct, users will be authorized to access the Set-up Menu; if the password is incorrect, the screen indicating your entered password is incorrect will appear. And the meter will return to the Password screen in 2 seconds.

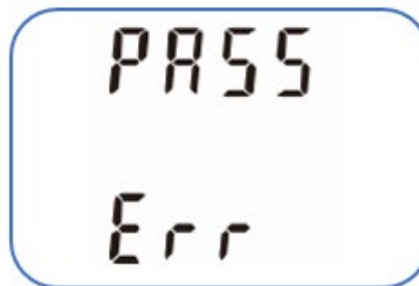

5. Short press the  button to return to the Set-up Menu.





➤ **To set the Modbus Address:**

1. Short press the  button or the  button to select the **Address ID** option.



2. Long press the  button to enter the setting routine — the first digit will be flashing.



3. Short press the  button or the  button to set the digit to the required number. And next, short press the  button to move right. The next digit will be flashing. Repeat the procedures to set the remaining digits.
4. When the Modbus address displays 003, long press the  button to confirm your setting.
5. Once the Modbus address is set properly, short press the  button to return to the Set-up Menu.



➤ **To set the Baud Rate**

1. Short press the  button or the  button to select the **Baud Rate** option.





2. Long press the  button to enter the setting routine — the current setting will be flashing.



3. Short press the  button or the  button to choose 9.6k from the existing values. And next, long press the  button to confirm your selection when 9.6k is displayed on the screen.

NOTE

If the default baud rate has been set as 9.6k, skip the steps above and long press the  button to confirm.

4. Once the baud rate is set to 9.6k, short press the  button to return to the Set-up Menu.

➤ To Set the Parity Bit

1. Short press the  button or the  button to select the **Parity** option.



2. Long press the  button to enter the setting routine — the current setting will be flashing.



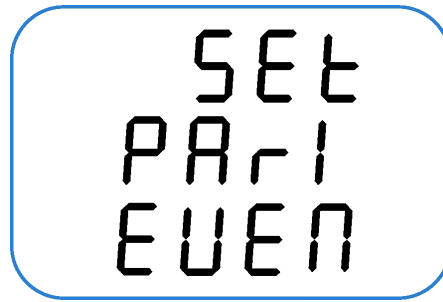

3. Short press the  button or the  button to select **EVEN** from the existing options.



4. Long press the  button to confirm your selection when **EVEN** is displayed on the screen.

NOTE

If the default parity bit has been set as EVEN, skip the steps above and long press the  button to confirm.

5. Once the parity bit is set properly, short press the  button to return to the Set-up Menu.



➤ To set Stop Bit

1. Short press the  button or the  button to select the **Stop Bit** option.





2. Long press the  button to enter the setting page — the current setting will be flashing.



3. Short press the  button or the  button to select 1 from the existing options. And next, long press the  button to confirm your selection when 1 is displayed on the screen.

NOTE

If the default stop bit has been set as 1, skip the steps above and long press the  button to confirm.

4. Once the stop bit is set properly, short press the  button to return to the Set-up Menu.

3.4.5 For DC Compact

To save time in purchasing an appropriate energy meter, the recommended energy meter is listed below, which can be purchased from local distributors.

Phase	Current Range	Part	Meter Type (Recommended)	CT Type (Recommended)
Three-phase	> 100 A	Meter + CT	SDM630MCT V2	ESCT-T24 250A/5A

After the meter is properly installed and connected to upstream MCB/RCBO, wire an RS-485 cable between the charger and meter.

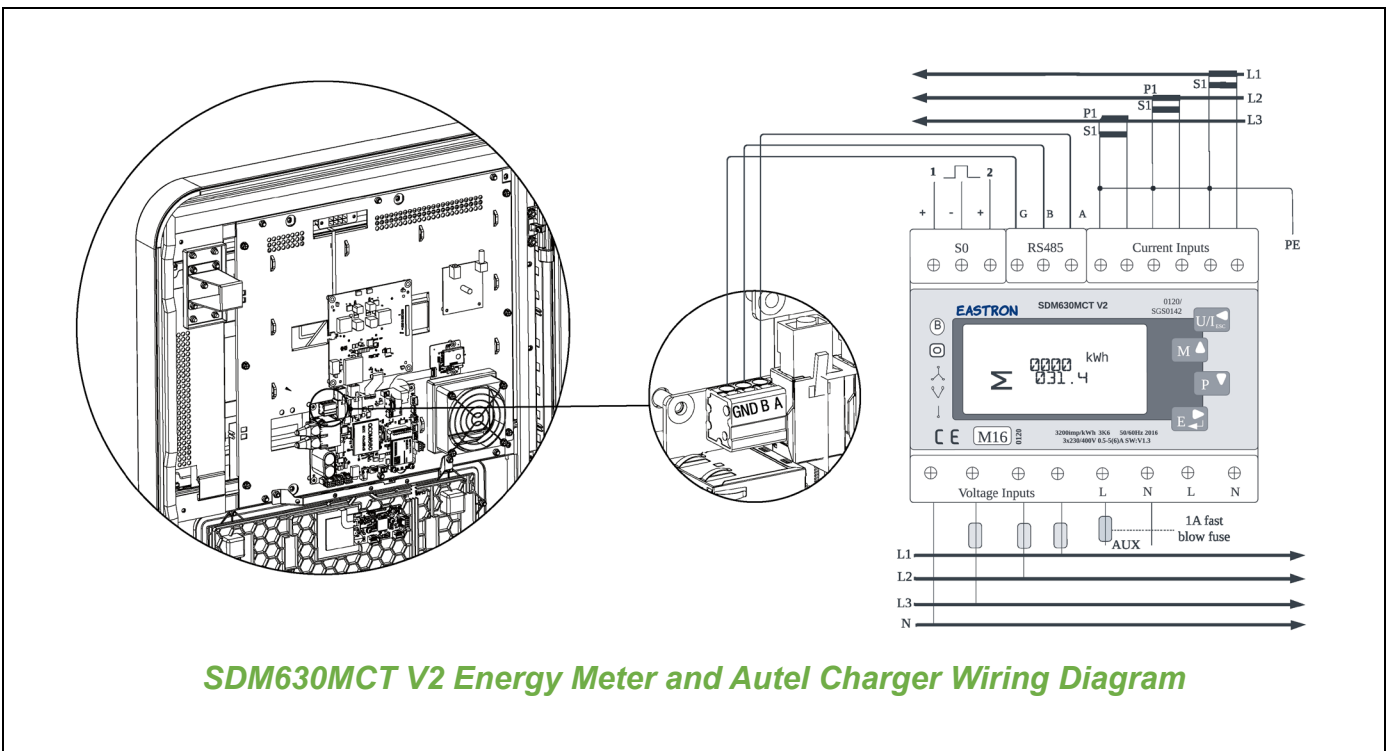

NOTE
Always keep the power turned off during wiring.

To establish a communication between the primary charger and the meter, the following settings of the meter should be completed:

- ◆ **Modbus Address:** 003
- ◆ **Baud Rate:** 9600
- ◆ **Parity Bit:** EVEN
- ◆ **Stop Bit:** 1

Refer to [3.4.4](#) to operate.

3.4.6 For DC Fast

To save time in purchasing an appropriate energy meter, the recommended energy meter is listed below, which can be purchased from local distributors.

Phase	Current Range	Part	Meter Type (Recommended)	CT Type (Recommended)
Three-phase	> 100 A	Meter + CT	SDM630MCT V2	ESCT-T24 250A/5A

After the meter is properly installed and connected to upstream MCB/RCBO, wire an RS-485 cable between the charger and meter.

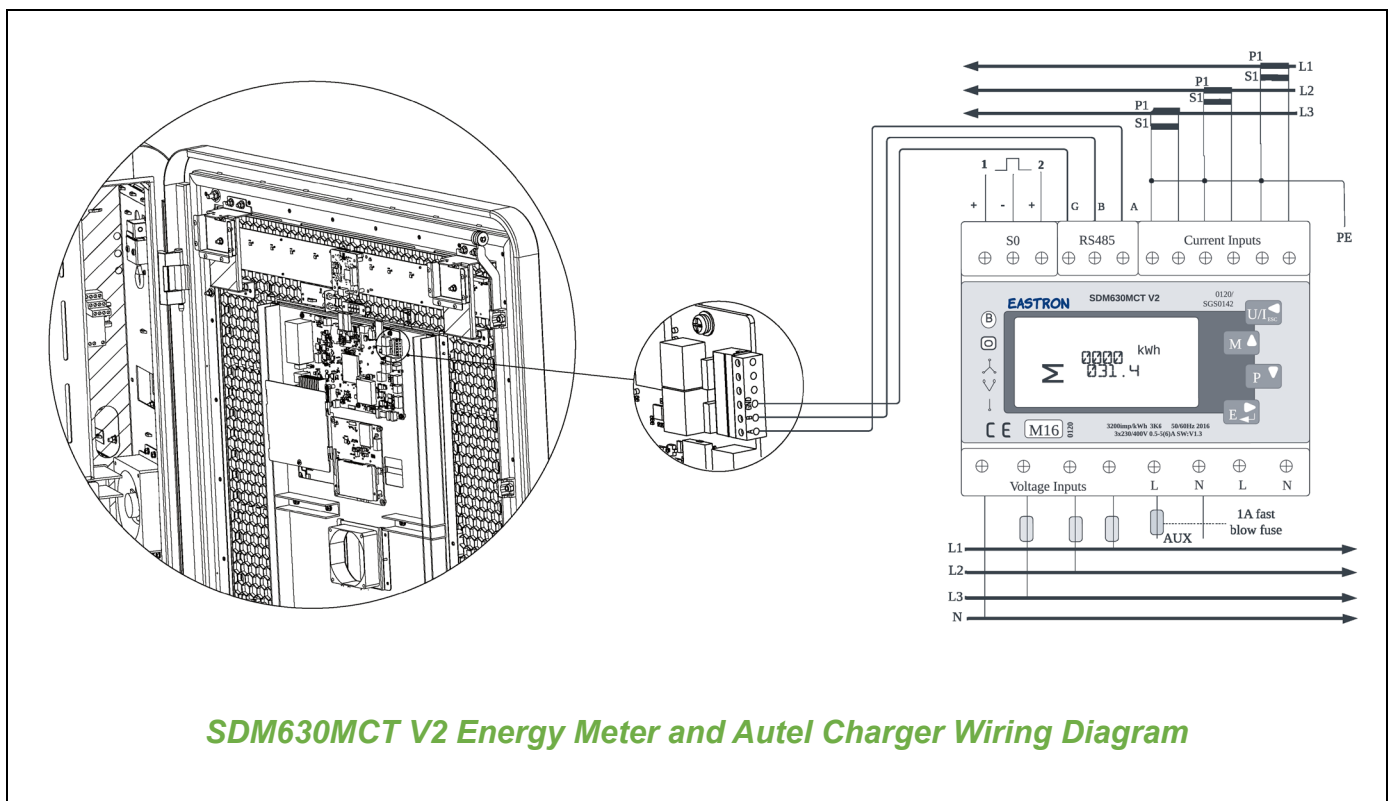

NOTE
Always keep the power turned off during wiring.

To establish a communication between the primary charger and the meter, the following settings of the meter should be completed:

- ◆ **Modbus Address:** 003
- ◆ **Baud Rate:** 9600
- ◆ **Parity Bit:** EVEN
- ◆ **Stop Bit:** 1

Refer to [3.4.4](#) to operate.

4 Configuration

All the chargers within the site can only be configured using the same method, the corresponding relationship between configuration methods and scenarios is as follows.

Configuration Method	Usage	Scenario
Autel Operation and Maintenance Platform (O&M)	Commercial environments	Single Charger
		Single Charger + AC Ultra/AC Elite(Wallbox)/AC Compact
		SmartBox + Single Charger
		SmartBox + Single Charger/AC Ultra/AC Elite (Wallbox)/AC Compact
		AC Ultra
		DC Compact/DC Fast
		AC Ultra + AC Wallbox/AC Compact
		DC Compact/DC Fast + AC Wallbox/AC Compact
On the Charger	Commercial environments	AC Ultra
		DC Compact/DC Fast
		AC Ultra + AC Wallbox/AC Compact
		DC Compact/DC Fast + AC Wallbox/AC Compact
Autel ChargeAPP	Residential environments	Single Charger
		AC Wallbox/AC Compact

4.1 Configuration through the Web

Follow the steps below to activate the operating modes via <https://omcb-eu.autel.com/> once you have installed and wired all the units according to the system diagram.

NOTE

The prerequisite for operation in this section is that the sites have been created in <https://omcb-eu.autel.com/> and the devices have been added under the sites.

4.1.1 For Scenarios with Commercial Environments

4.1.1.1 Set up DLB Mode

1. Log in to the Autel Operation and Maintenance Platform (O&M) by inputting the account and the password. The URL of the platform is <https://omcb-eu.autel.com/>.

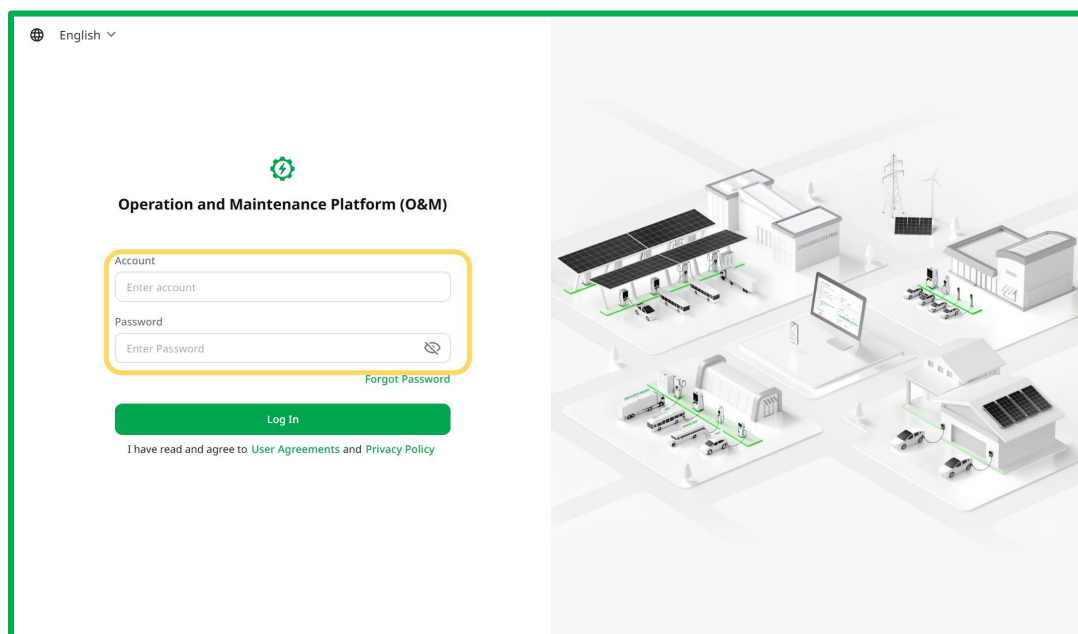

2. Click the site to be configured in the list on the **Sites** page. The corresponding page is opened.

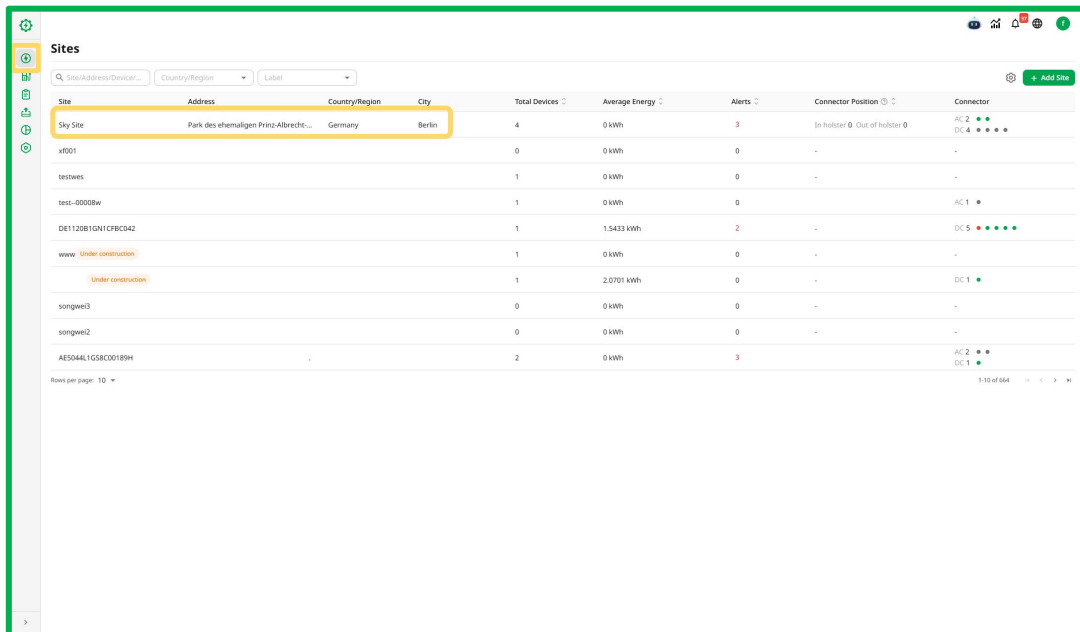

3. Click **Load Balancing**, switch to the **Load Balancing** tab.

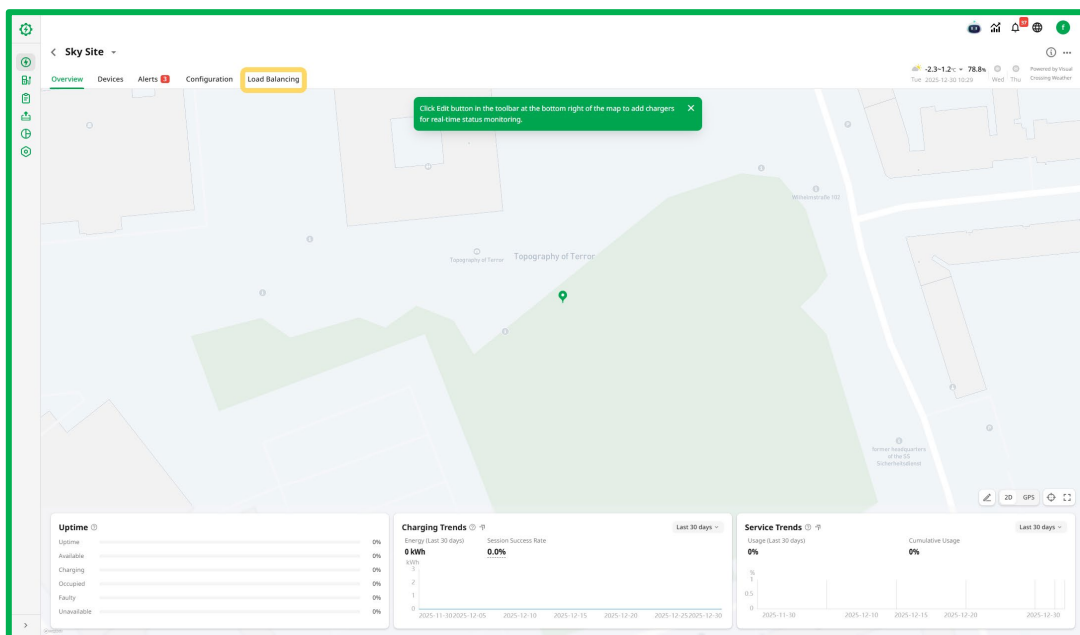

4. Click **Start Configuration** in the **Load Balancing** tab.

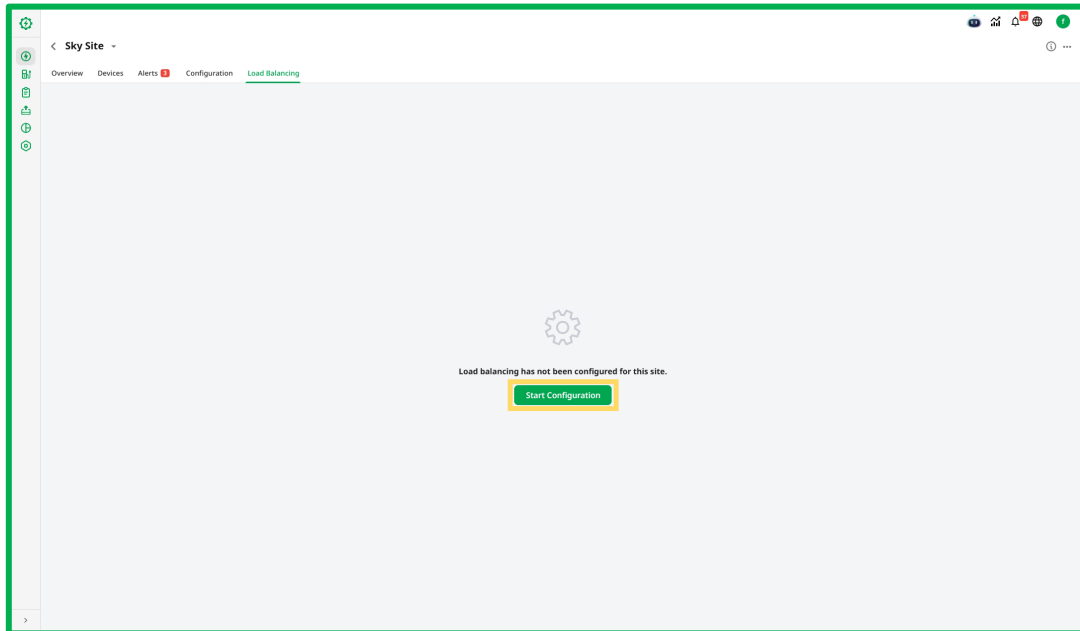

5. Setting the site attributes related to Load Balancing.

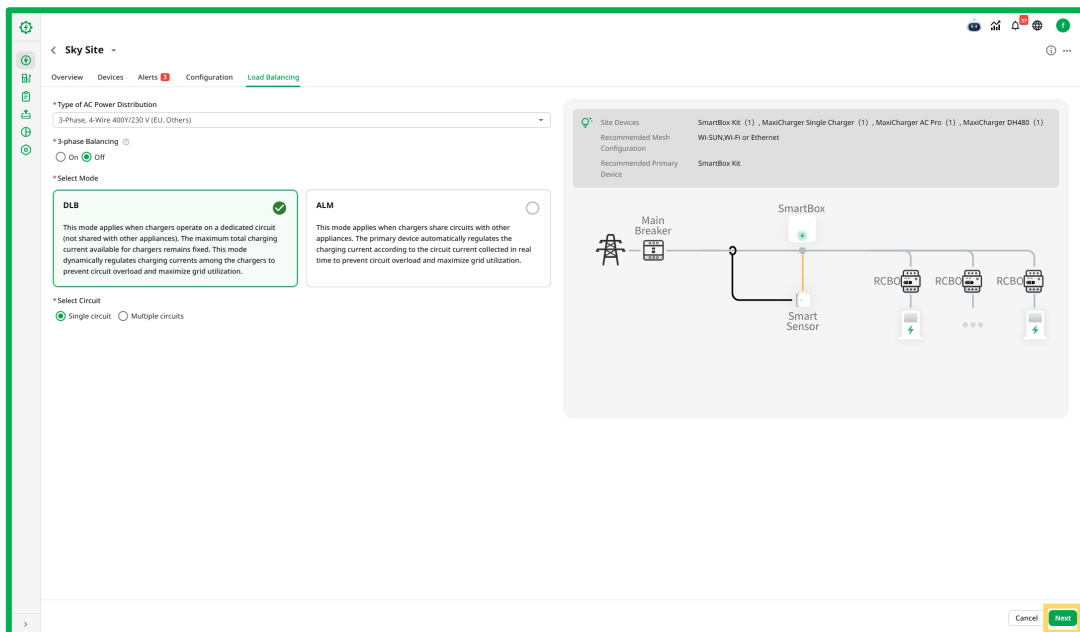

- ✓ **Types of AC Power Distribution:** select based on the actual type of AC power distribution for the site.
- ✓ **3-phase Balancing:** select **On** or **Off** based on requirements.
 - ◆ When **On** is selected, it means the primary device can monitor three-phase grid currents and single-phase vehicle demand, and dynamically select the optimal phase for power supply.
 - ◆ Configuration is allowed only when **Types of AC Power Distribution** is 3-phase and there are second-generation chargers equipped with diverter switches in the site.
- ✓ **Select Mode:** select **DLB**.
- ✓ **Select Circuit:** select based on the actual conditions of the site. The topology diagram is

updated in real-time on the right side of the **Load Balancing** tab according to changes in parameter configurations.

Click **Next**.

6. Configure the **Configuring Main Circuit Parameters** tab.

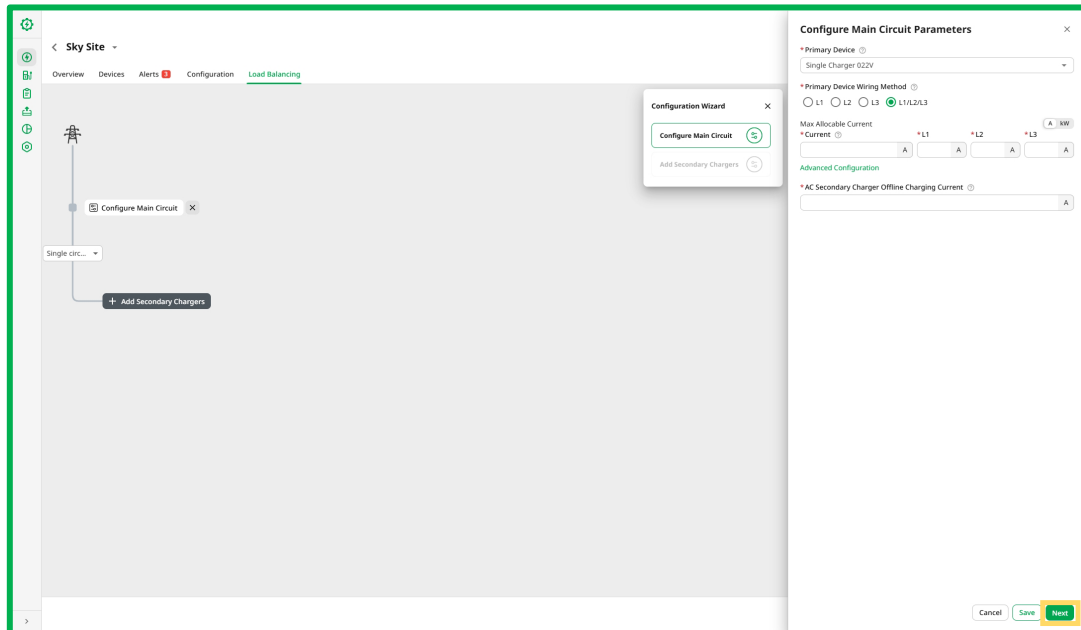

- ✓ **Primary Device:** Select either a SmartBox or a charger based on the actual conditions.
 - ◆ When the **Primary Device** is a SmartBox, the secondary chargers can be AC chargers, DC chargers or a mix of both.
 - ◆ When the **Primary Device** is an AC charger, the secondary chargers must be AC chargers, the same rule applies to DC chargers.
- ✓ **Primary Device Wiring Method:** configure based on the actual conditions.
- ✓ **Max Allocable Current:** configure based on the actual conditions.
- ✓ **Advanced Configuration:** optional configuration. Configure the mode for Maximum Allocable Current and the specific current settings.
- ✓ **Secondary Chargers Offline Current:** configure based on the actual conditions.

When there are multiple circuits in the site, configure the remaining circuits according to the **Configuration Wizard**.

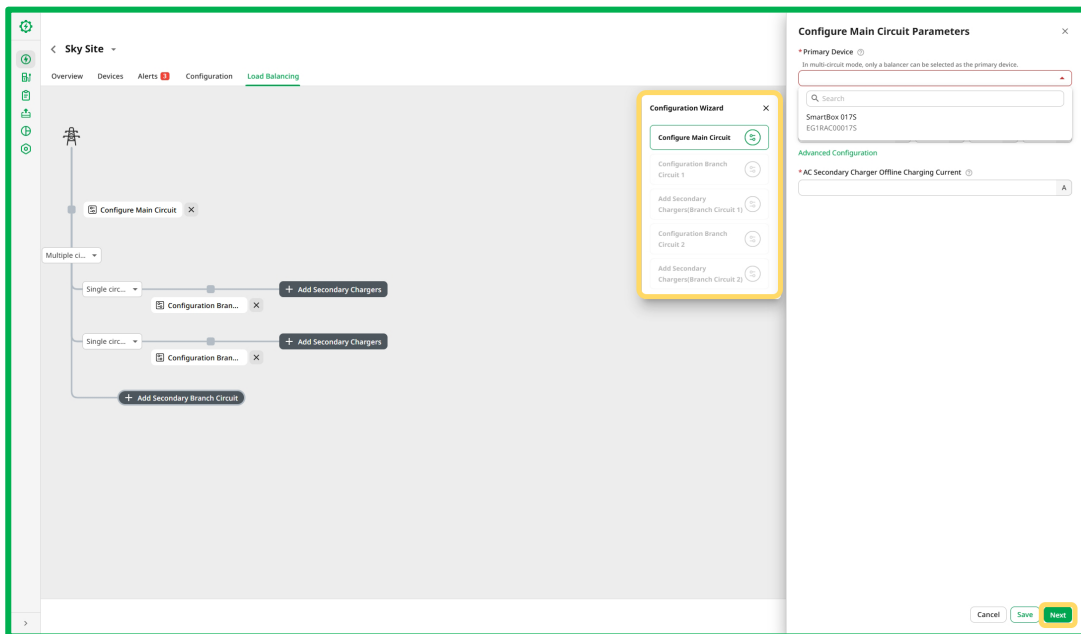

Click **Next**.

NOTE
 You can temporarily save the current configuration by clicking **Save** to resume configuration later.

7. **Add secondary chargers.** Add secondary chargers in batches by entering the device SNs or manually select secondary chargers from the **Device** list.

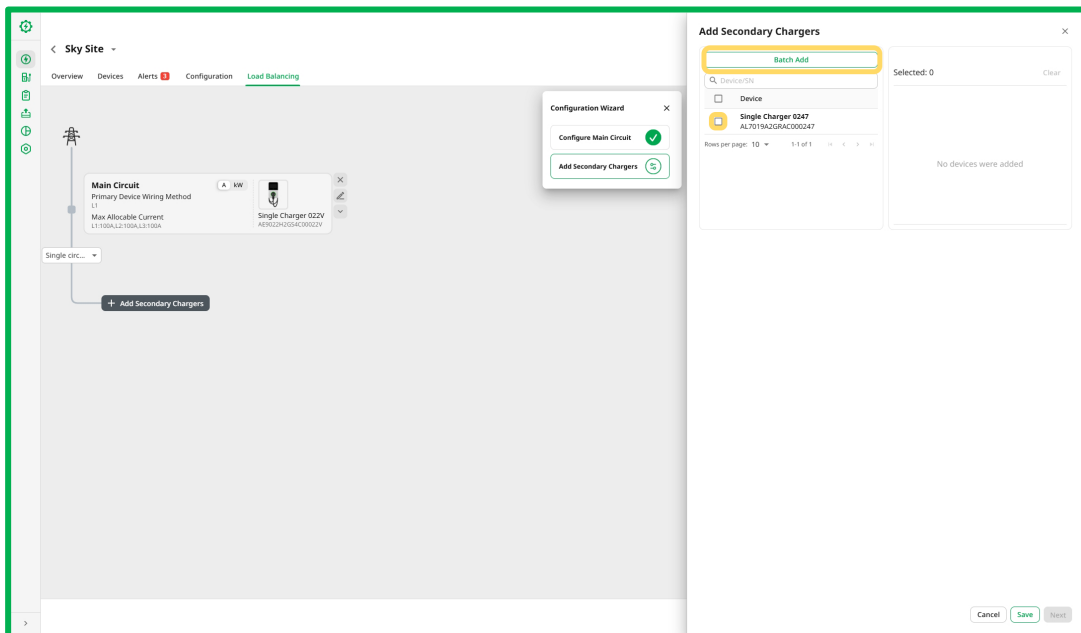

Click **Next**.

8. **Configure wiring method.** Manually check wiring method (L1/L2/L3) for each secondary charger (single-phase chargers can be wired to different phases). The topology diagram is updated in real-time on the left side of the current page according to configuration changes.

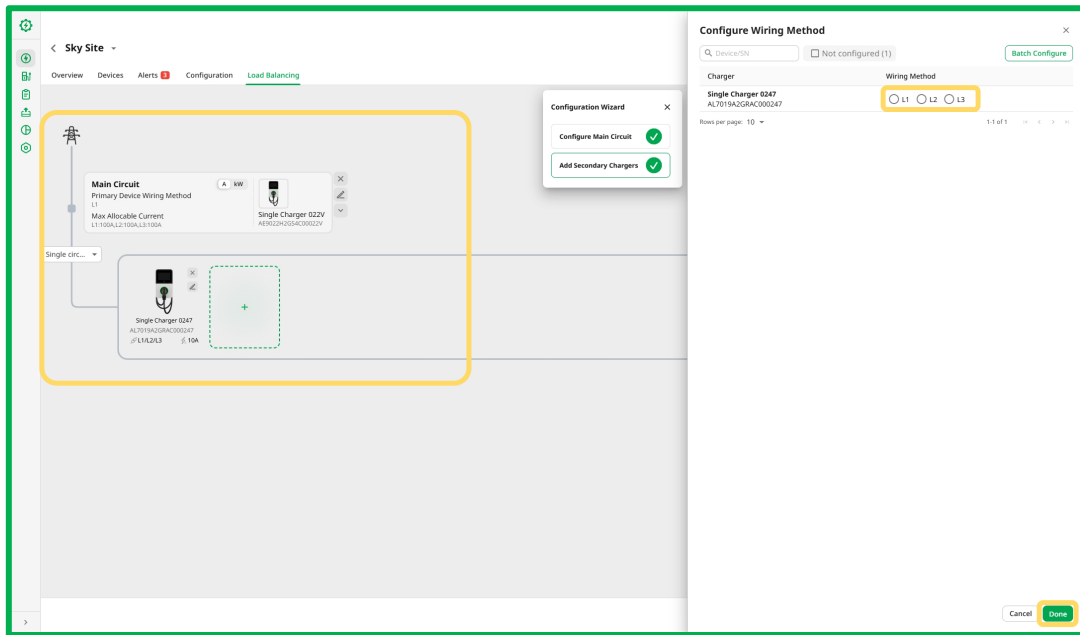

Click **Done**.

9. Perform a final check and modification of the configuration. Click **Submit**.

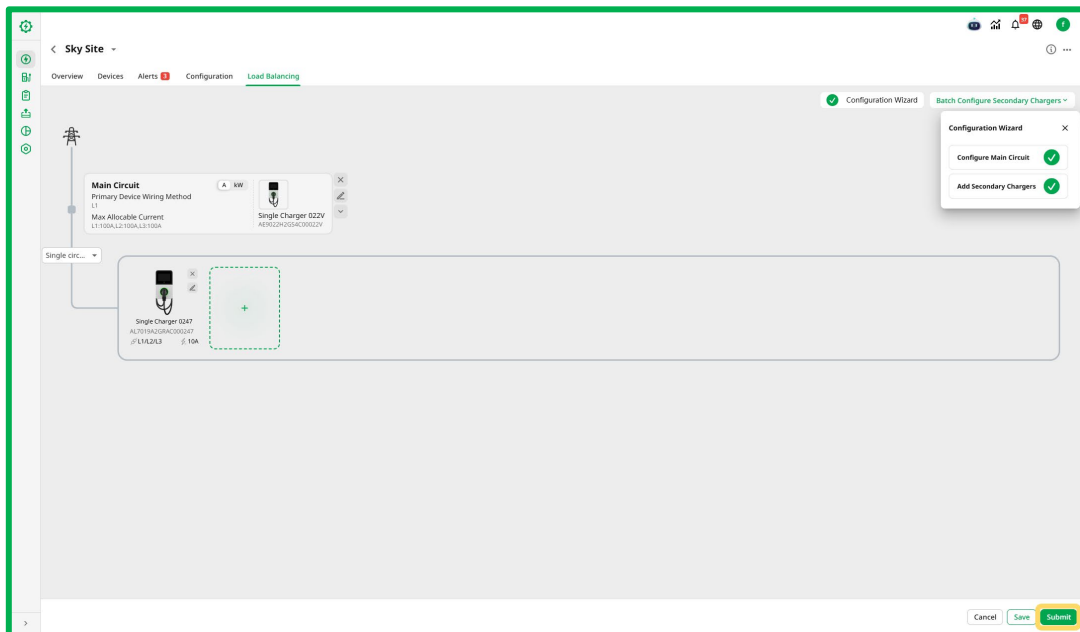

NOTE

You can temporarily save the current configuration by clicking **Save** to resume configuration later.

4.1.1.2 Set up ALM Mode

1. Log in to the Autel Operation and Maintenance Platform (O&M) by inputting the account and the password. The URL of the platform is <https://omcb-eu.autel.com/>.

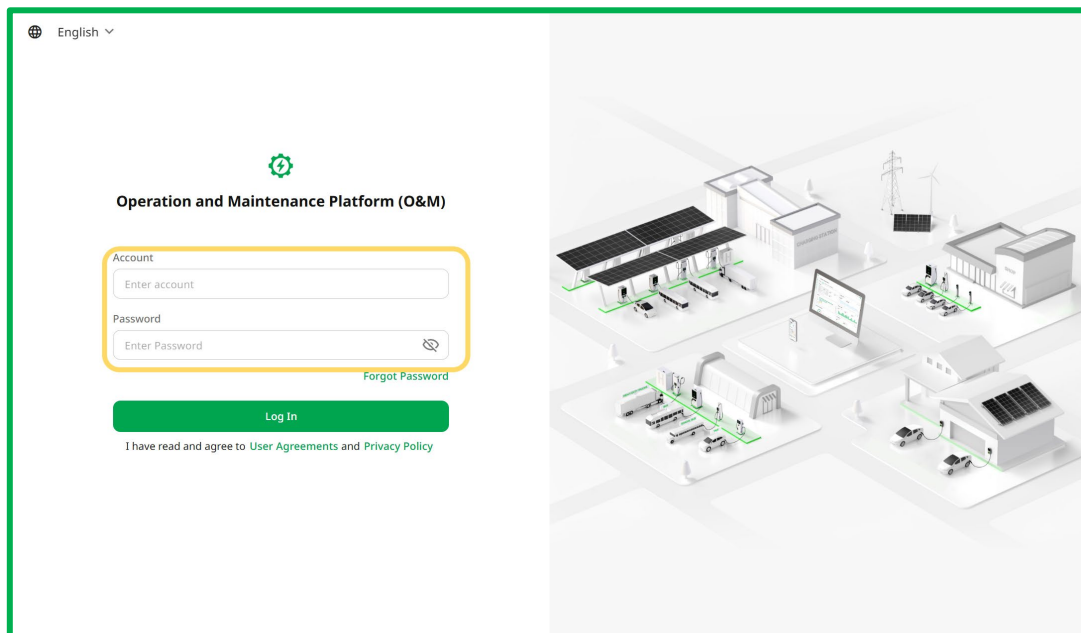

2. Click the site to be configured in the list on the **Sites** page. The corresponding page is opened.

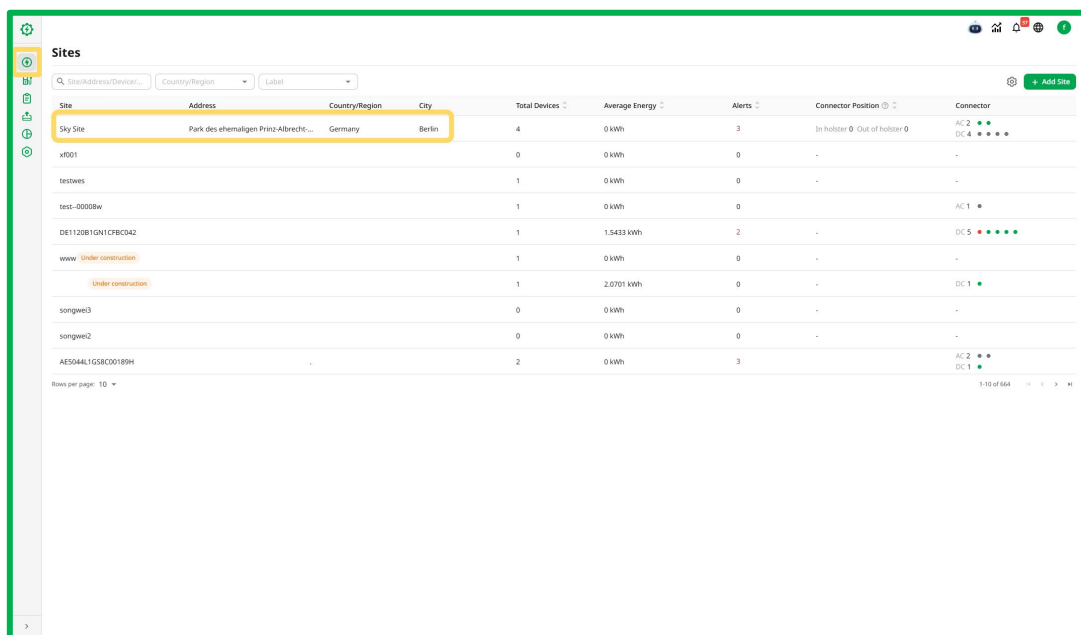

Site	Address	Country/Region	City	Total Devices	Average Energy	Alerts	Connector Position	Connector
Sky Site	Park des ehemaligen Prinz-Albrecht...	Germany	Berlin	4	0 kWh	3	In holster 0 Out of holster 0	AC 2 DC 4
x001				0	0 kWh	0	-	-
testwes				1	0 kWh	0	-	-
test--0008w				1	0 kWh	0	-	AC 1
DE112081GN1CFBC042				1	1.5433 kWh	2	-	DC 5
www	Under construction			1	0 kWh	0	-	-
	Under construction			1	2.0701 kWh	0	-	DC 1
songwe3				0	0 kWh	0	-	-
songwe2				0	0 kWh	0	-	-
AES0441G58C00189H				2	0 kWh	3	-	AC 2 DC 1

3. Click **Load Balancing**, switch to the **Load Balancing** tab.

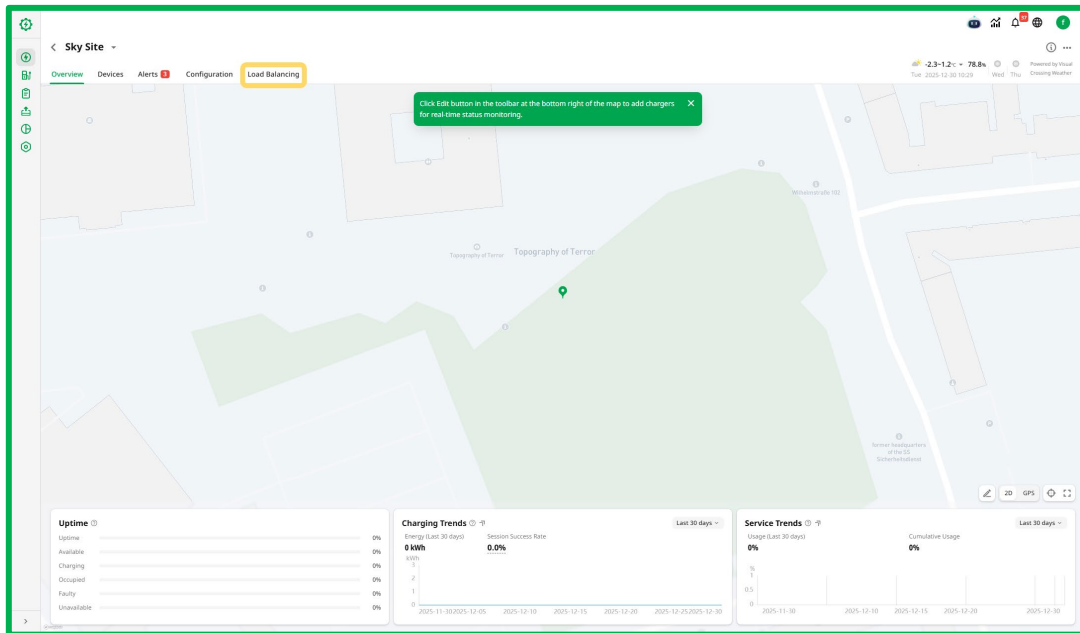

4. Click **Start Configuration** in the **Load Balancing** tab.

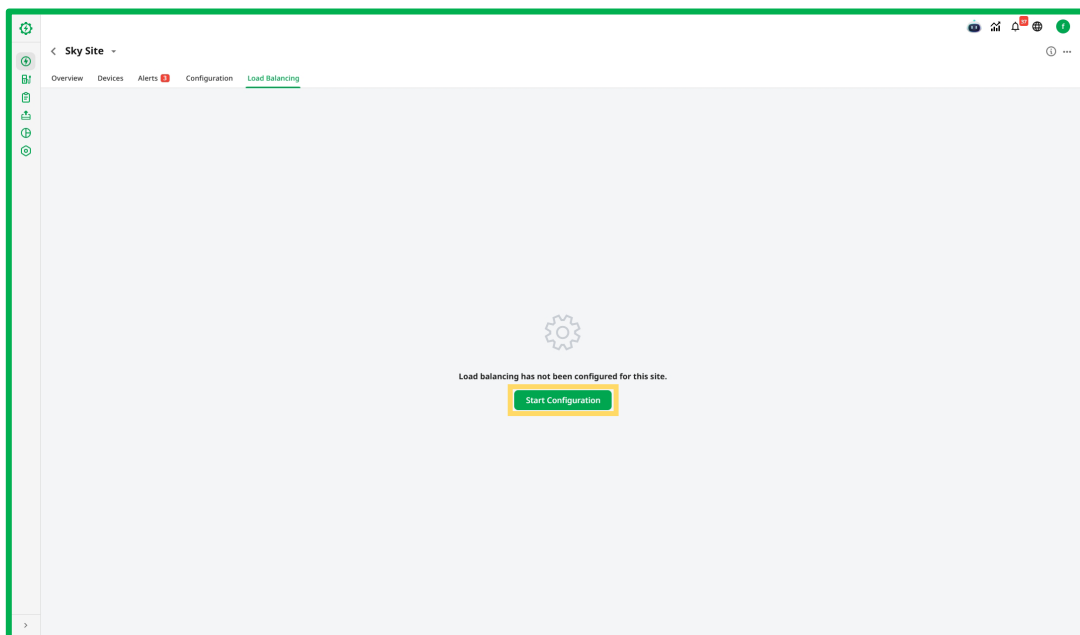

5. Setting the site attributes related to Load Balancing.

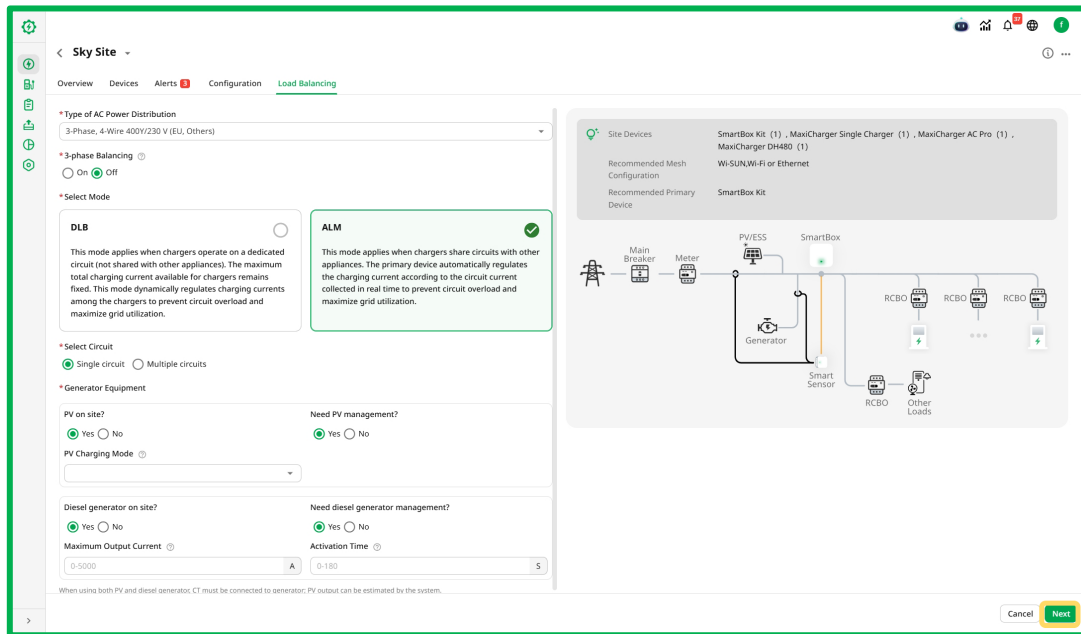

- ✓ **Types of AC Power Distribution:** select based on the actual type of AC power distribution for the site.
- ✓ **3-phase Balancing:** select **On** or **Off** based on requirements.
 - ◆ When **On** is selected, it means the primary device can monitor three-phase grid currents and single-phase vehicle demand, and dynamically select the optimal phase for power supply.
 - ◆ Configuration is allowed only when **Types of AC Power Distribution** is 3-phase and there are second-generation chargers equipped with diverter switches on the site.
- ✓ **Select Mode:** select **ALM**.
- ✓ **Select Circuit:** select based on the actual conditions. The topology diagram is updated in real-time on the right side of the **Load Balancing** tab according to changes in parameter configurations.
- ✓ **PV on site?:** select based on the actual conditions. When there is no PV on the site, set **PV on site?** as **No**. When **PV on site?** is selected as **Yes**, you can further set whether PV management is required.
- ✓ **Diesel generator on site?:** select based on the actual conditions. When there is no diesel generator on the site, set **Diesel generator on site?** as **No**. When **Diesel generator on site?** is selected as **Yes**, you can further set whether diesel generator management is required.

Click **Next**.

6. Switch to the **Configuring Main Circuit Parameters** tab.

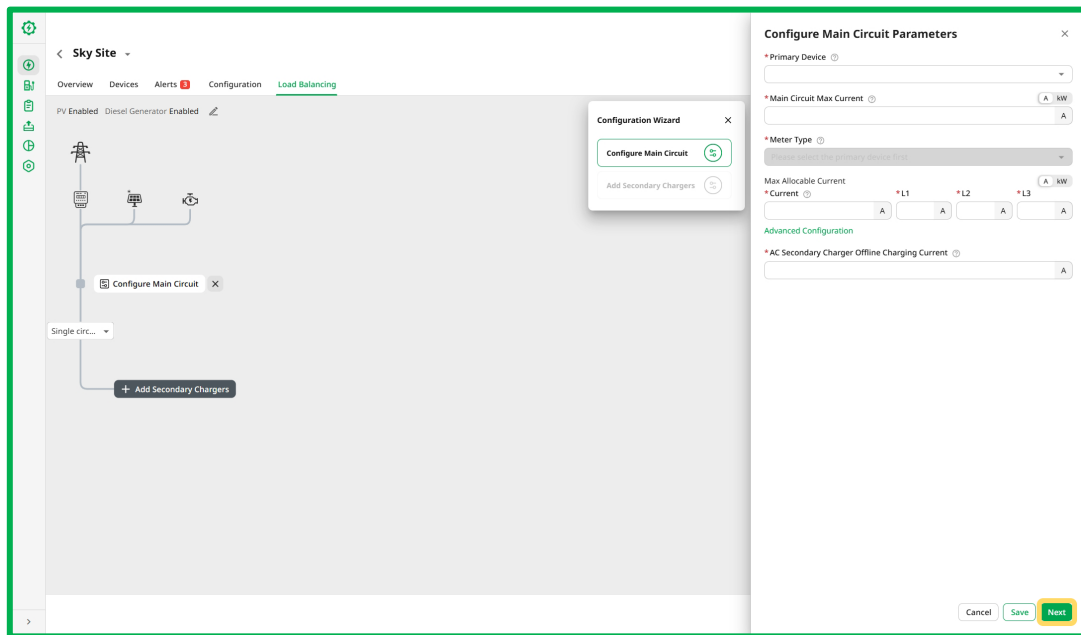

- ✓ **Primary Device:** select either a SmartBox or a charger based on the actual conditions.
 - ◆ When the **Primary Device** is a SmartBox, the secondary chargers can be AC chargers, DC chargers or a mix of both.
 - ◆ When the **Primary Device** is an AC charger, the secondary chargers must be AC chargers, the same rule applies to DC chargers.
- ✓ **Meter Type:** select the type of device used by the primary device to collect the real-time current of the main circuit.
- ✓ **Primary Device Wiring Method:** configure based on the actual conditions.
- ✓ **Max Allocable Current:** configure based on the actual conditions.
- ✓ **Advanced Configuration:** optional configuration. Configure the mode for Maximum Allocable Current and the specific current settings.
- ✓ **Secondary Chargers Offline Current:** configure based on the actual conditions.

When there are multiple circuits in the site, configure the remaining circuits according to the **Configuration Wizard**.

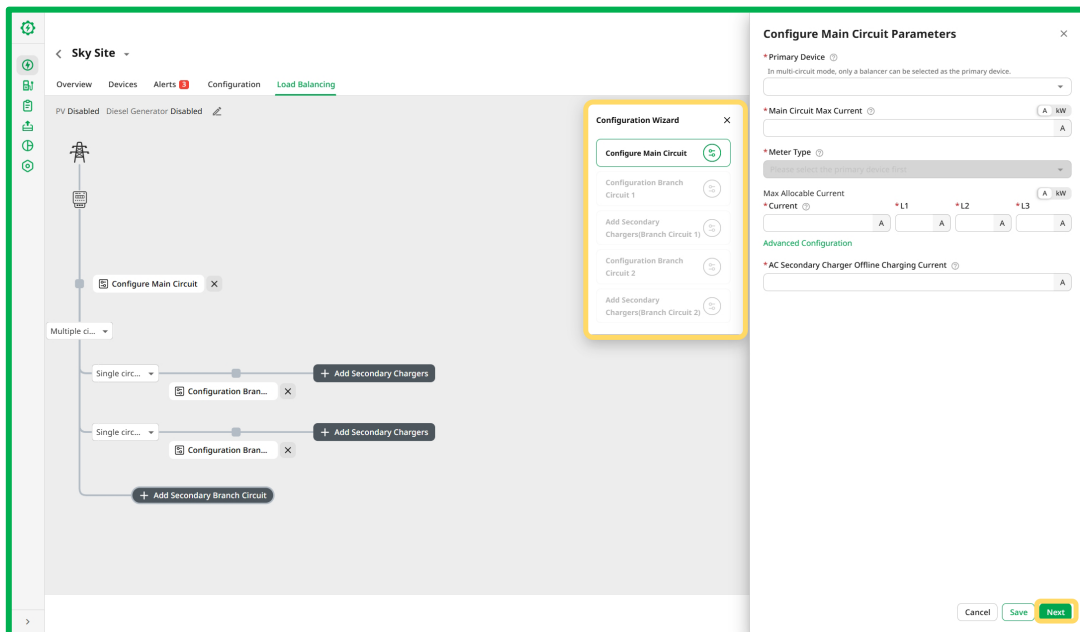

Click **Next**.

NOTE
You can temporarily save the current configuration by clicking **Save** to resume configuration later.

7. **Add secondary chargers.** Add secondary chargers in batches by entering the device SNs or manually select secondary chargers from the **Device** list.

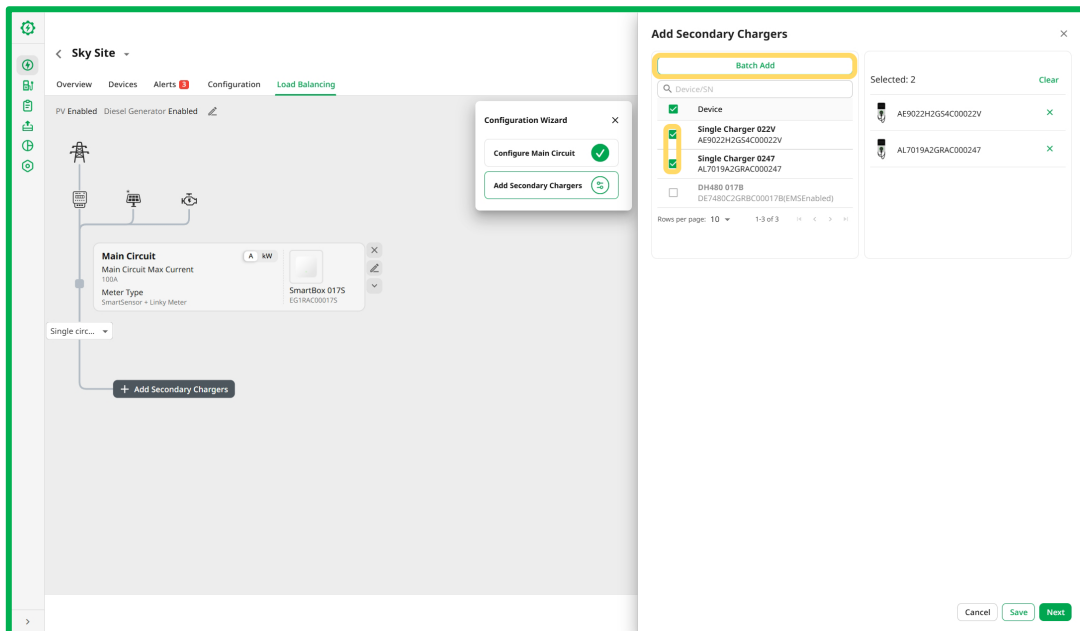

Click **Next**.

8. **Configure wiring method.** Manually check wiring method (L1/L2/L3) for each secondary charger (single-phase chargers can be wired to different phases). The topology diagram is updated in real-time on the left side of the current page according to configuration changes.

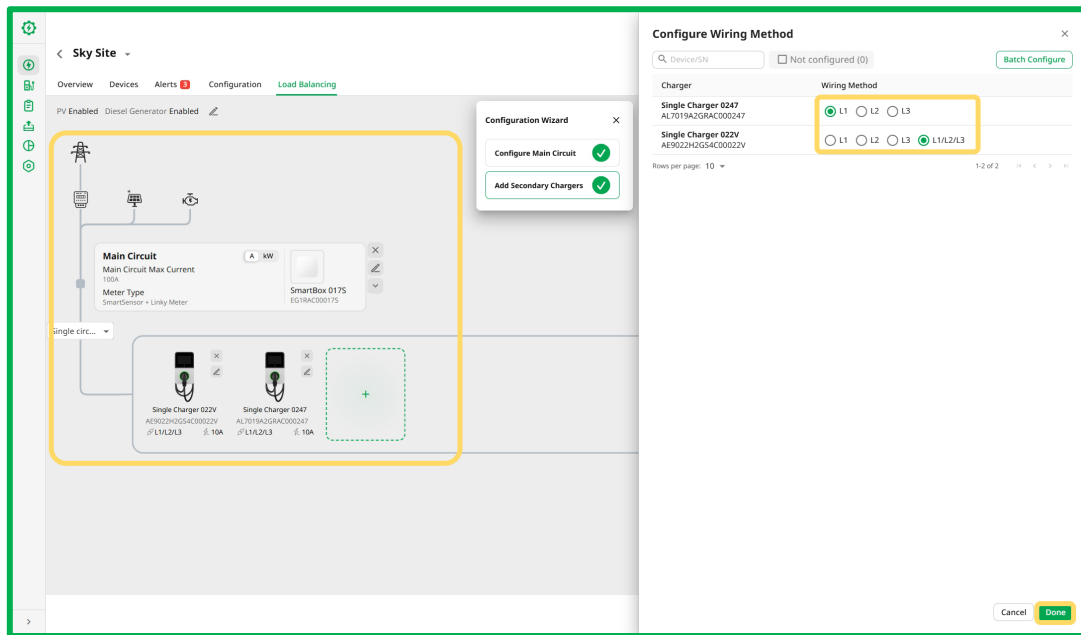

Click **Done**.

9. Perform a final check and modification of the configuration. Click **Submit**.

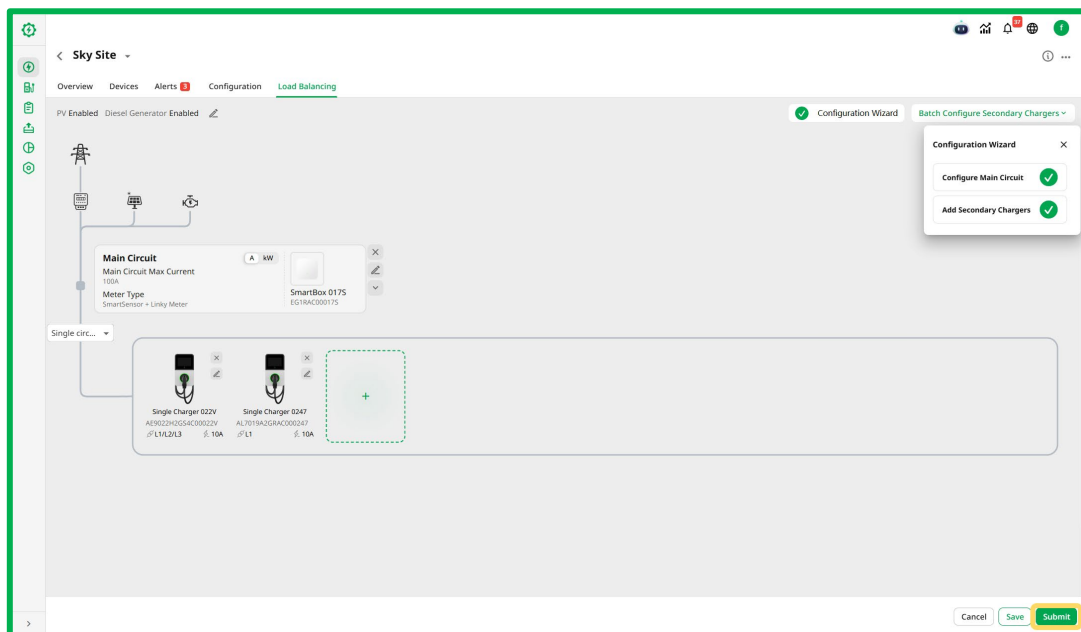

NOTE

You can temporarily save the current configuration by clicking **Save** to resume configuration later.

4.2 Configuration on the Charger

Follow the steps below to activate the operating modes on the charger once you have installed and wired all the units according to the system diagram.

4.2.1 For Scenario with AC Ultra/DC Compact/DC Fast

4.2.1.1 Set up DLB mode

1. Refer to **STEP 1-4** in [3.3.4](#) to enter the **Device Maintenance** screen. Then select **ALM-DLB**.

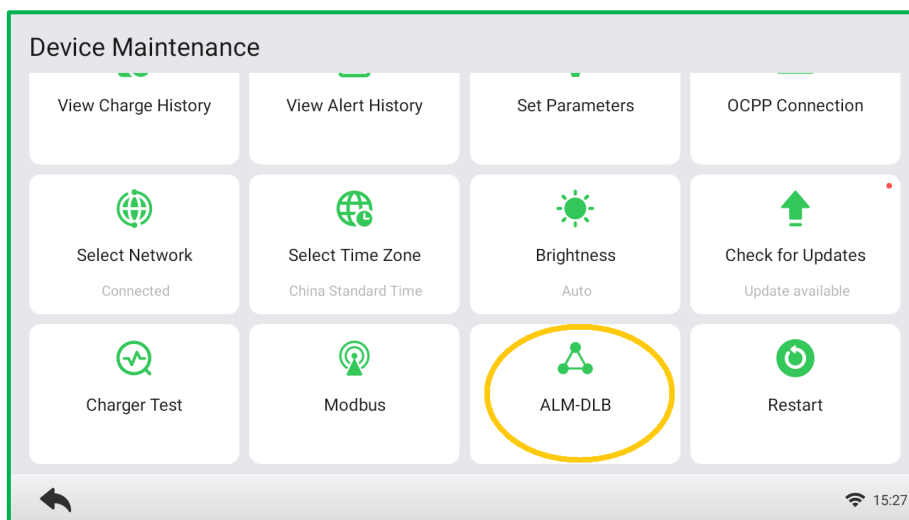

2. Set secondary charger.

- 1) Enable **ALM-DLB Switch** as shown below.
- 2) Click on ">" to the right of the **Role** and select **Secondary charger**.
- 3) Configure the parameters of **Maximum Charging Power of Charger** and **Charging Power of Offline Charger**.
 - ✓ **Maximum Charging Power of Charger (kW)**: lower than the rated power of the charger.
 - ✓ **Charging Power of Offline Charger (kW)**: this value is 0 by default.

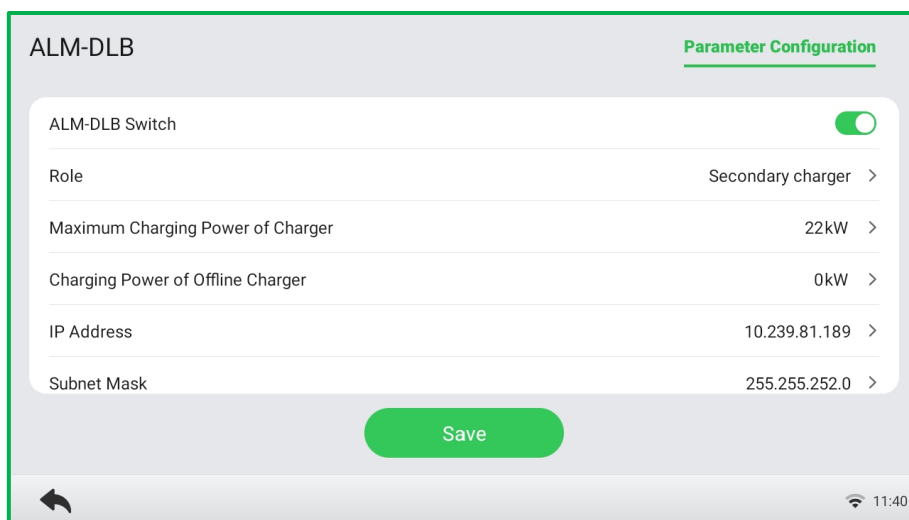

- 4) **Record the IP Address** for the follow-up configuration and click on the **Save** button to save the setup.
- 5) Set the remaining secondary chargers and configure their parameters successively according to the previous steps.

3. Set primary charger.

- 1) Refer to **STEP 1** to enter the **Device Maintenance** screen and select **ALM-DLB**.
- 2) Enable **ALM-DLB Switch** as shown below.
- 3) Click on ">" to the right of the **Role** and select **Primary charger**.

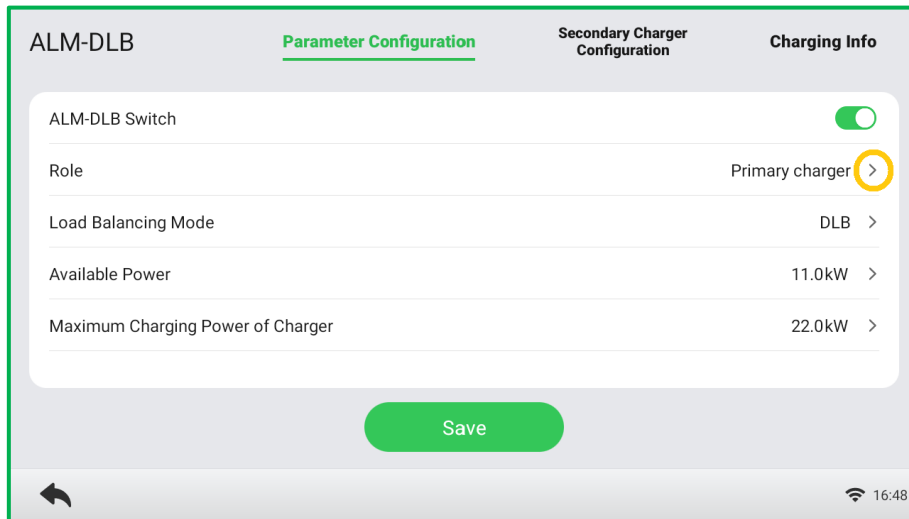

4. Set up DLB mode.

- 1) Click on ">" to the right of the **Load Balancing Mode** and select **DLB**.

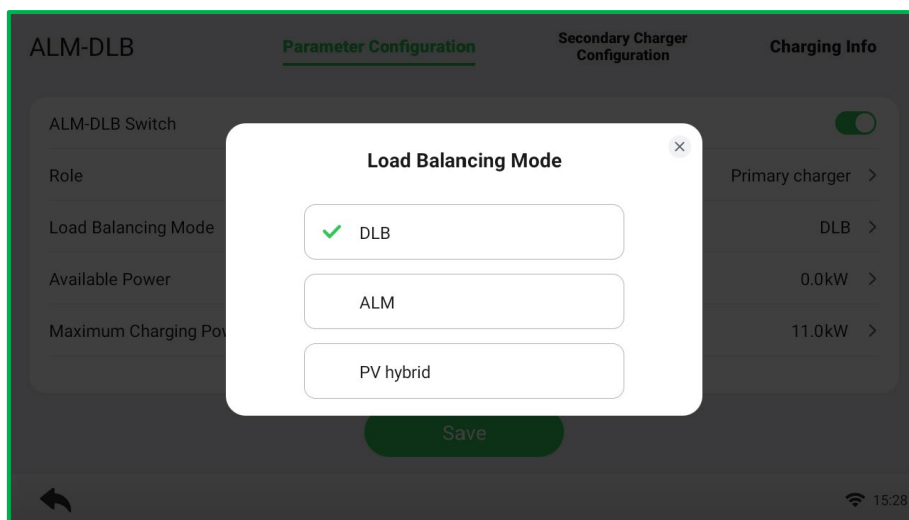

- 2) Configure the parameters of **Available Power** and **Maximum Charging Power of Charger**.

- ✓ **Available Power (kW):** You must enter the available power that the system can supply to the chargers. This value must be expressed as a whole number.

The value of the available power should be within the following range:

- ◆ Maximum Value: lower than the upstream MCB/RCBO rated power.
- ◆ Minimum Value: higher than the minimum power of one charger (1.4 kW for single-phase, 4.2 kW for three-phase) x N (N represents the number of chargers in the device group).

✓ **Maximum Charging Power of Charger:** lower than the rated power of the charger.

Click on the **Save** button to save the settings.

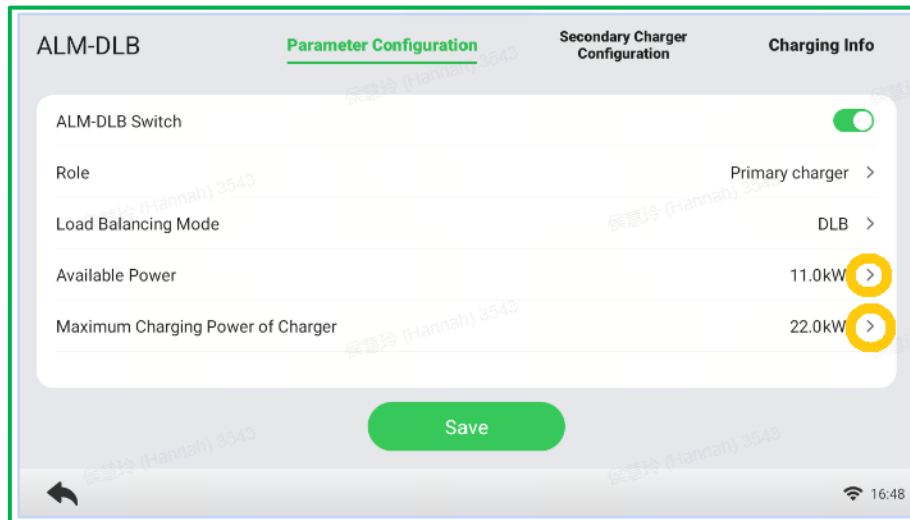

5. **Add secondary charger.** Tap on **Secondary Charger Configuration** and click on **Add Secondary Charger**. Add the secondary charger by inputting the recorded IP address and click on the **Save** button to save the setup.

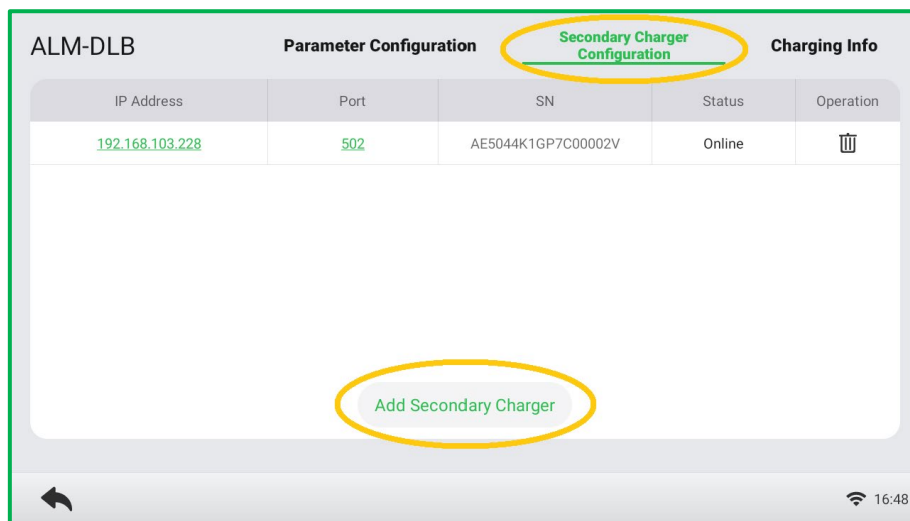

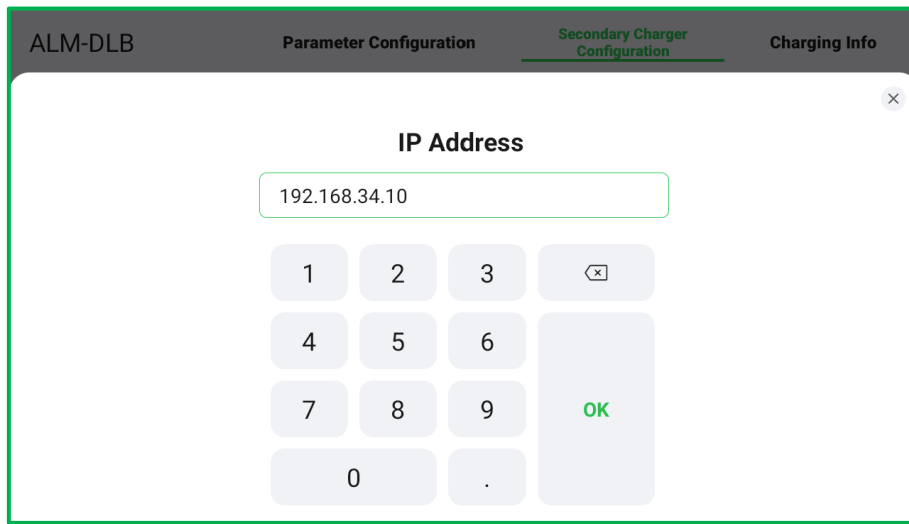

6. **Confirm configuration.** After all the setups above are completed, tap on **Charging Information** to confirm the configuration of the selected operating mode.

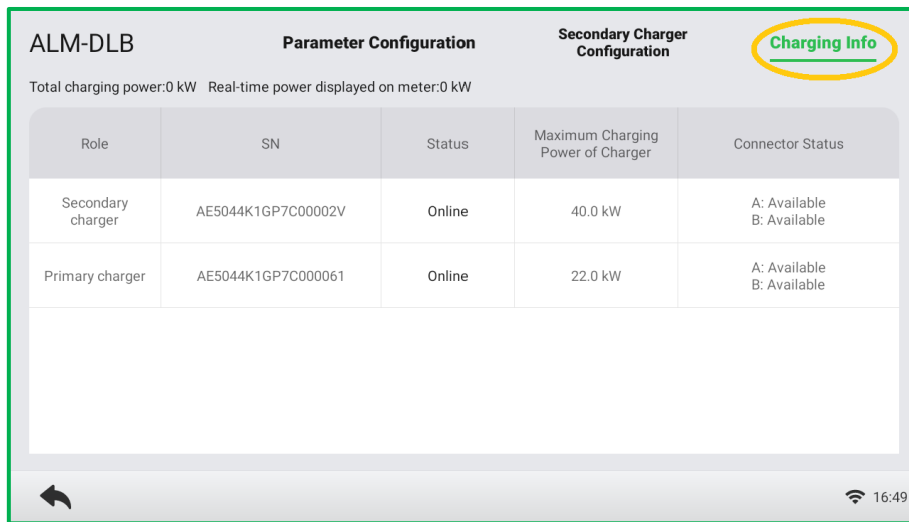

4.2.1.2 Set up ALM Mode w/Individual Charger

1. Refer to **STEP 1-4** in [3.3.4](#) to enter the **Device Maintenance** screen and select **ALM-DLB**.

2. **Set primary charger.** Enable **ALM-DLB Switch** as shown below. Then click on “>” to the right of the **Role** and select **Primary charger**.

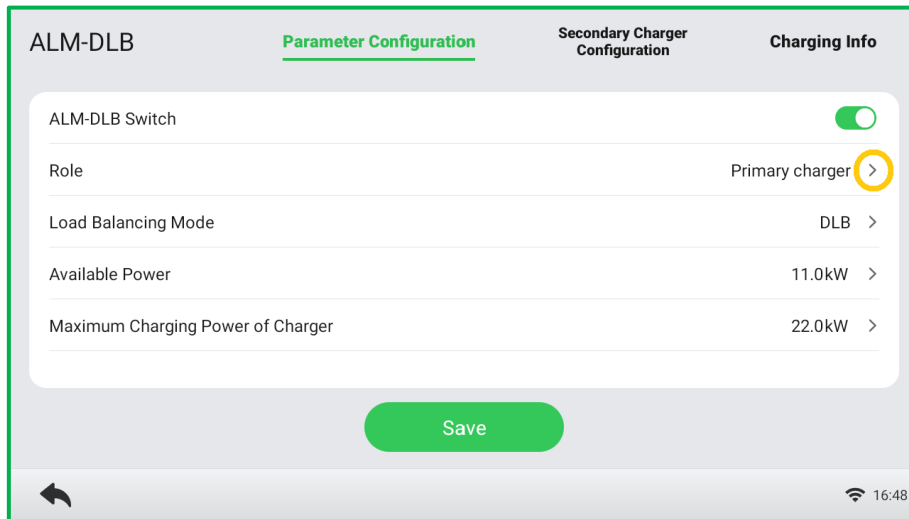

3. **Set up ALM mode.** On the same screen, click on “>” to the right of the **Load Balancing Mode** and select **ALM**.

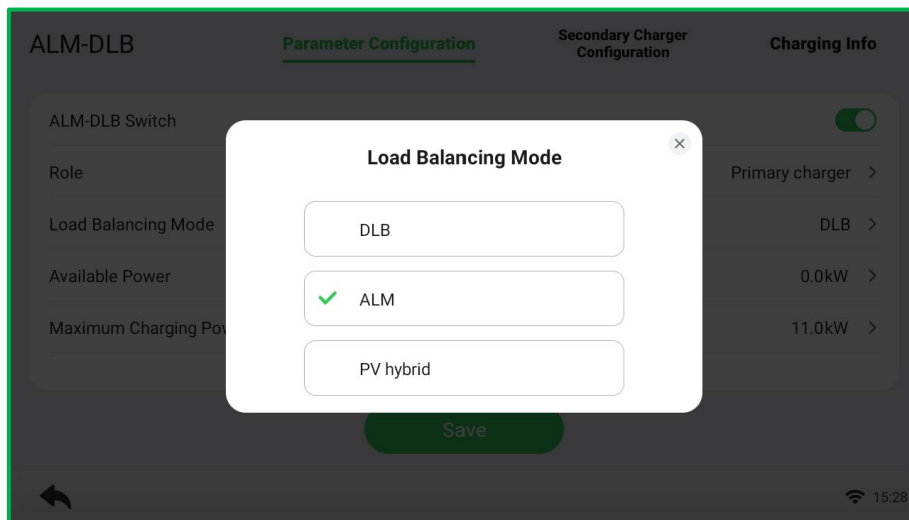

- 1) Click on “>” to the right of the **Meter Type** and select the meter.

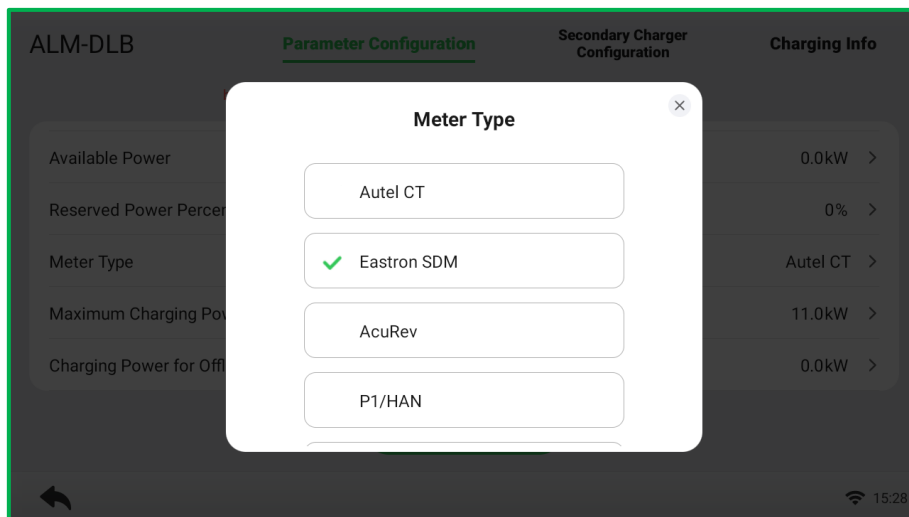

2) Configure the parameters of **Available Power**, **Reserved Power Percentage**, **Maximum Charging Power of Charger**, and **Charging Power for Offline Meter**.

- ✓ **Available Power (kW):** you need to enter the available power that the system can supply to the chargers. You must enter a whole number.

The value of the available power should be within the following range:

- ◆ **Maximum Value:** lower than the upstream MCB/RCBO rated power.
- ◆ **Minimum Value:** higher than the minimum power of one charger (1.4 kW for single-phase, 4.2 kW for three-phase) x N (N represents the number of chargers in the device group).

- ✓ **Reserved Power Percentage:** you must enter the power reserve for the charger, namely the reserved power not used for charging.

- ◆ The range of the power reserve is from 0–50%. The maximum reserved power that can be entered is 50% of the total home power.
- ◆ The default setting of the power reserve is 10%, which is used for the dynamic power change caused by load switching in and out.

- ✓ **Maximum Charging Power of Charger:** lower than the rated power of the charger.

- ✓ **Charging Power for Offline Meter:** the default charging power for offline meter is 10% of the available power.

Tap **Save** once you have completed the settings.

The screenshot shows a mobile application interface for configuring parameters. At the top, there are four tabs: 'ALM-DLB', 'Parameter Configuration' (which is selected and underlined in green), 'Secondary Charger Configuration', and 'Charging Info'. Below the tabs is a list of five settings, each with a value and a right-pointing arrow: 'Available Power' (0.0kW), 'Reserved Power Percentage' (0%), 'Meter Type' (Autel CT), 'Maximum Charging Power of Charger' (11.0kW), and 'Charging Power for Offline Meter' (0.0kW). At the bottom center of the list is a green rounded rectangular button labeled 'Save'. The bottom of the screen features a navigation bar with a back arrow on the left and a Wi-Fi signal icon and the time '15:28' on the right.

4. **Confirm configuration.** After all the setups above are completed, tap on **Charging Information** to confirm the configuration of the selected operating mode.

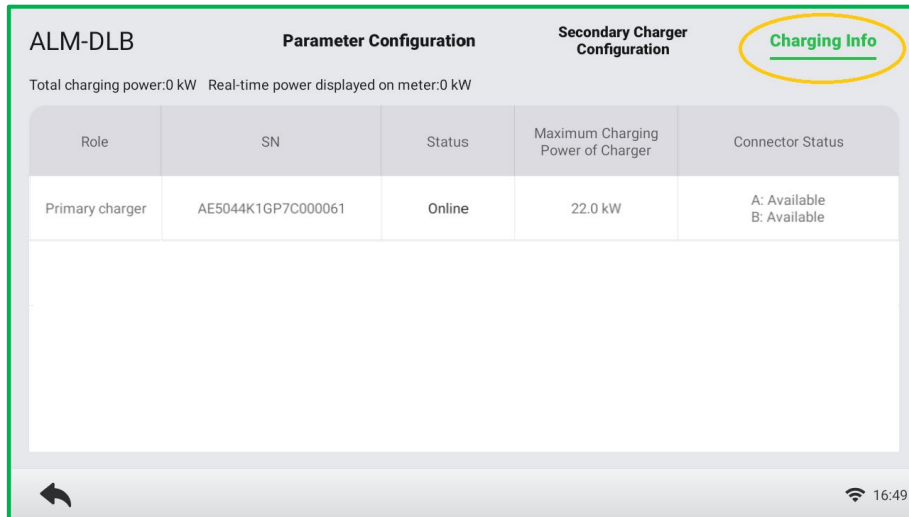

4.2.1.3 Set up ALM Mode w/Multiple Chargers

1. Refer to **STEP 1-4** in [3.3.4](#) to enter the **Device Maintenance** screen and select **ALM-DLB**.
2. **Set secondary charger.**
 - 1) Enable **ALM-DLB Switch** as shown below.
 - 2) Click on “>” to the right of the **Role** and select **Secondary charger**.

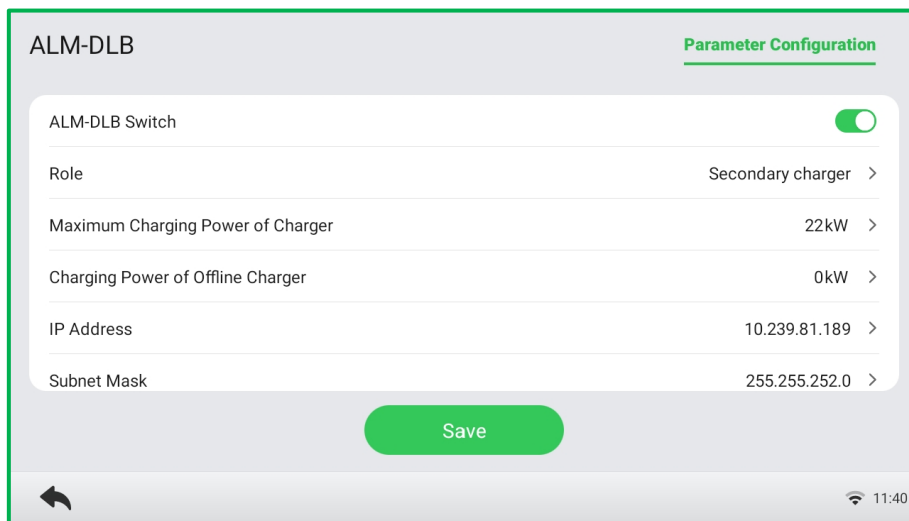

3) Configure the parameters of **Maximum Charging Power of Charger** and **Charging Power of Offline Charger**.

- ✓ **Maximum Charging Power of Charger (kW)**: lower than the rated power of the charger.
- ✓ **Charging Power of Offline Charger (kW)**: this value is 0 by default.

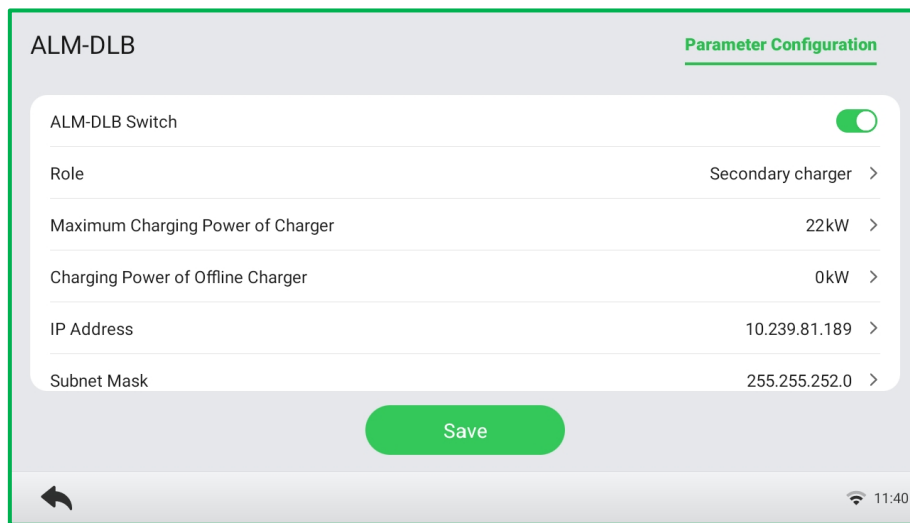

4) **Record the IP Address** for the follow-up configuration and click on the **Save** button to save the setup.

5) Set the remaining secondary chargers and configure their parameters successively according to the previous steps.

3. Set primary charger.

- 1) Refer to **STEP 1-4** in [3.3.4](#) to enter the **Device Maintenance** screen and select **ALM-DLB**.
- 2) Enable **ALM-DLB Switch** as shown below.
- 3) Click on ">" to the right of the **Role** and select **Primary charger**.

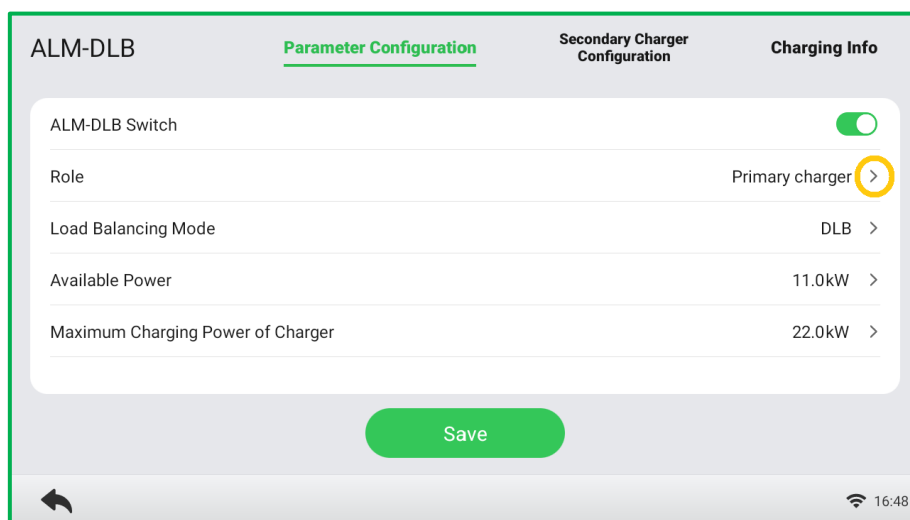

4. Set up ALM mode.

- 1) Click on “>” to the right of the **Load Balancing Mode** and select **ALM**.

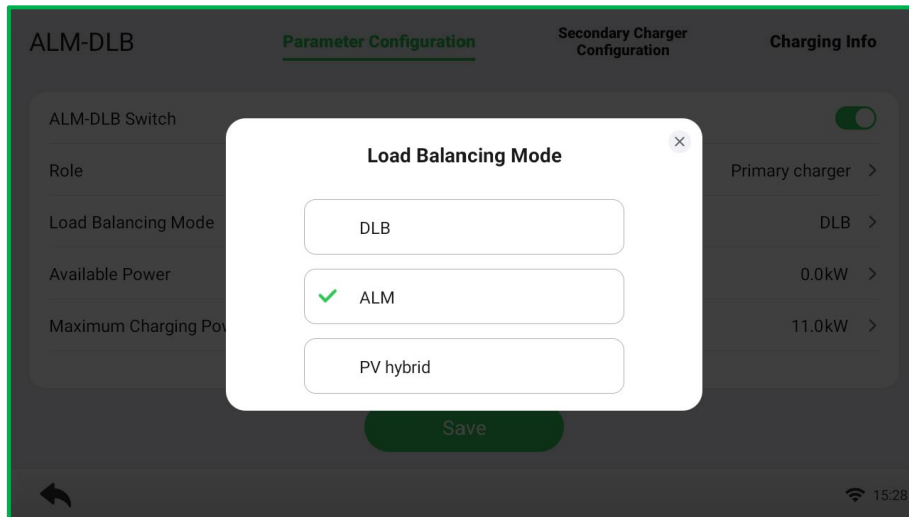

- 2) Click on “>” to the right of the **Meter Type** and select the meter.

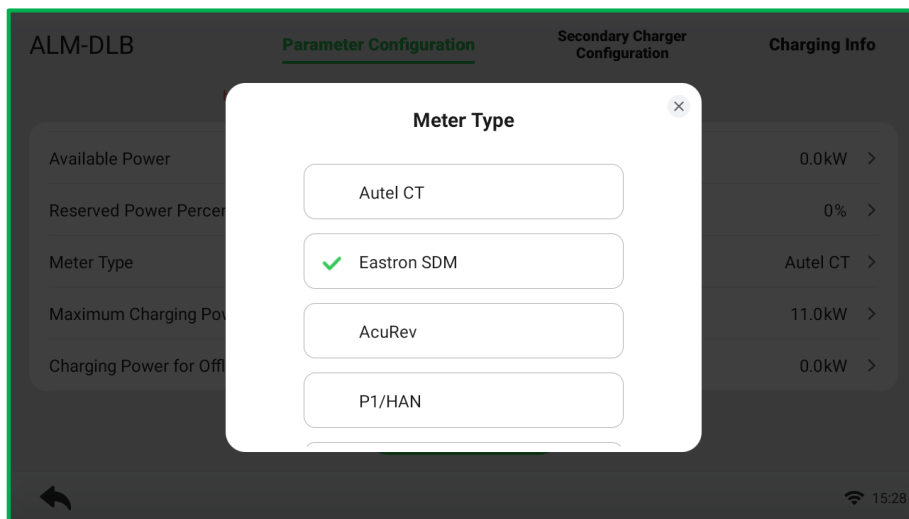

- 3) Configure the parameters of **Available Power**, **Reserved Power Percentage**, **Maximum Charging Power of Charger** and **Charging Power for Offline Meter**.

- ✓ **Available Power (kW)**: you need to enter the available power that the system can supply to the chargers. You must enter a whole number.

The value of the available power should be within the following range:

- ◆ **Maximum Value**: lower than the upstream MCB/RCBO rated power.
- ◆ **Minimum Value**: higher than the minimum power of one charger (1.4 kW for single-phase, 4.2 kW for three-phase) x N (N represents the number of chargers in the device group).

- ✓ **Reserved Power Percentage:** you must enter the power reserve for the charger, namely the reserved power not used for charging.
 - ◆ The range of the power reserve is from 0–50%. The maximum reserved power that can be entered is 50% of the total home power.
 - ◆ The default setting of the power reserve is 10%, which is used for the dynamic power change caused by load switching in and out.
- ✓ **Maximum Charging Power of Charger:** lower than the rated power of the charger.
- ✓ **Charging Power for Offline Meter:** the default charging power for offline meter is 10% of the available power.

Click on the **Save** button to save the settings.

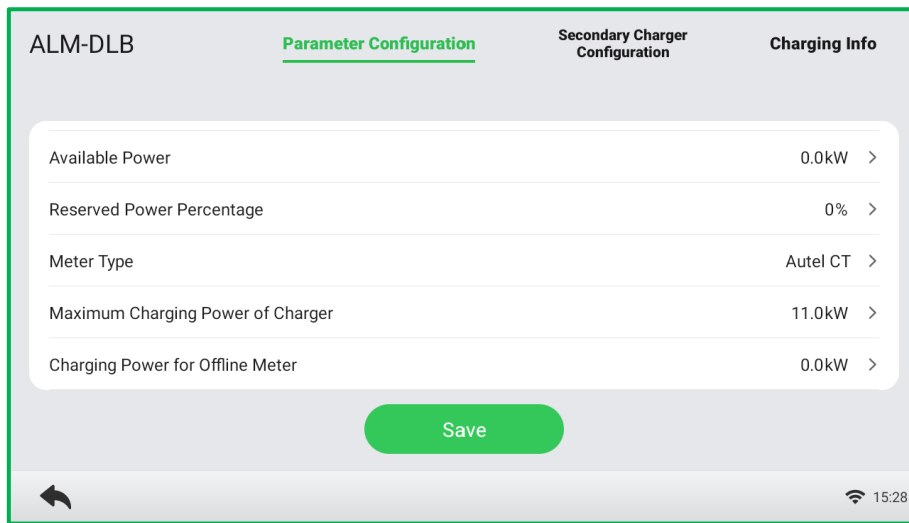

5. **Add secondary charger.** Tap on **Secondary Charger Configuration** and click on **Add Secondary Charger**. Add the secondary charger by inputting the recorded IP address and click on the **Save** button to save the setup.

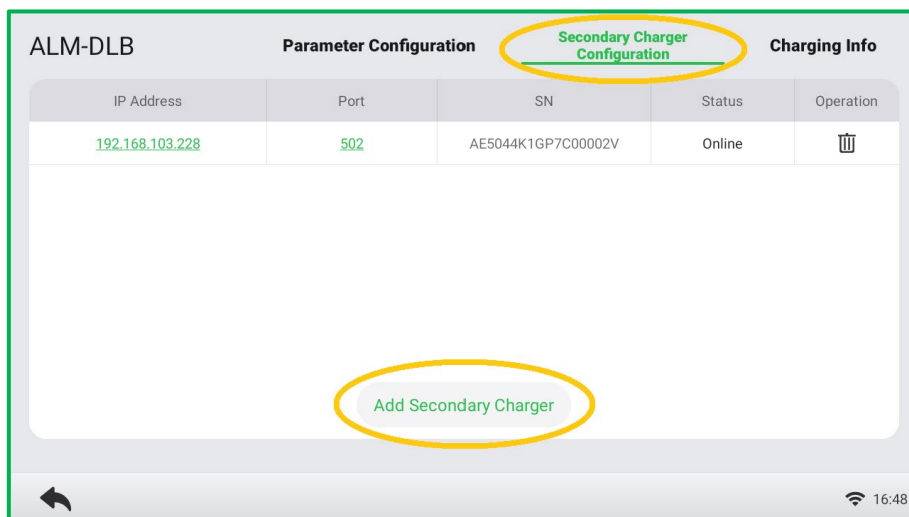

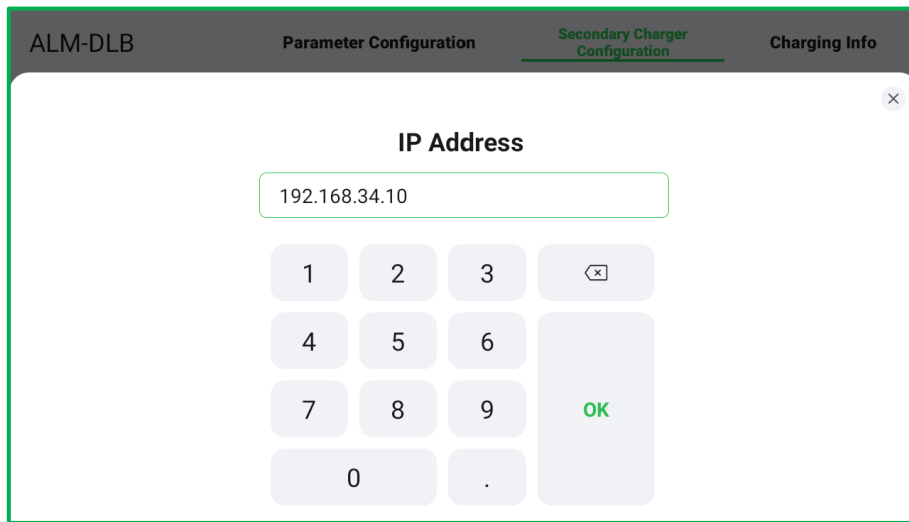

6. **Confirm configuration.** After all the setups above are completed, tap on **Charging Information** to confirm the configuration of the selected operating mode.

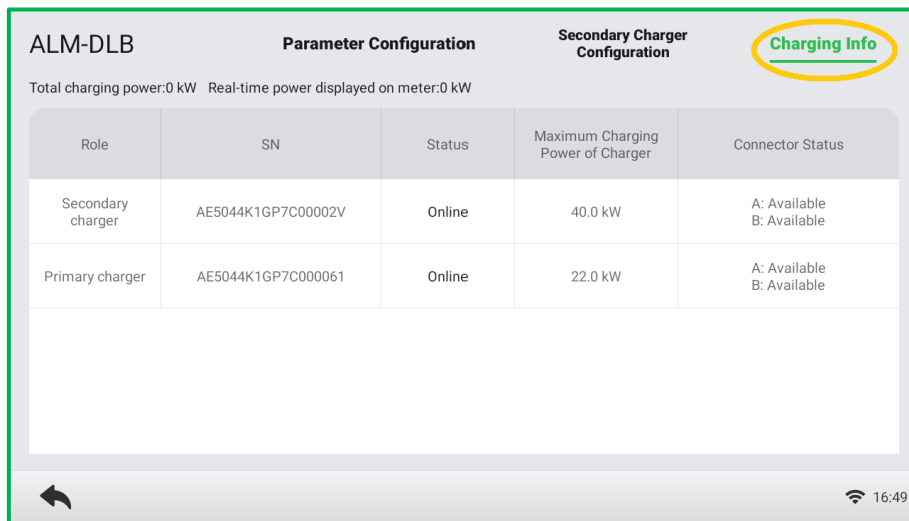

4.2.1.4 Set up PV Hybrid Mode w/Individual Charger

1. Refer to **STEP 1-4** in [3.3.4](#) to enter the **Device Maintenance** screen and select **ALM-DLB**.

2. **Set primary charger.** Enable **ALM-DLB Switch** as shown below. Then click on “>” to the right of the **Role** and select **Primary charger**.

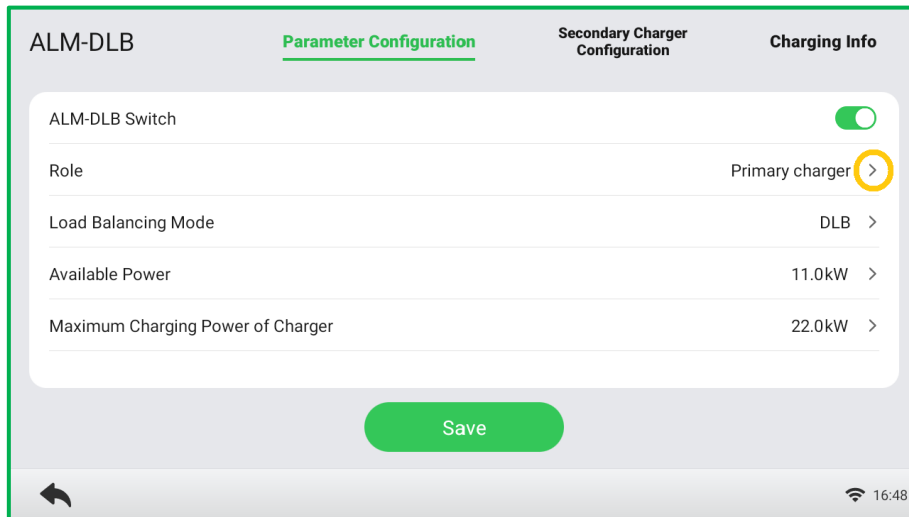

3. **Set up PV hybrid mode.** On the same screen, click on “>” to the right of the **Load Balancing Mode** and select **PV Hybrid**.

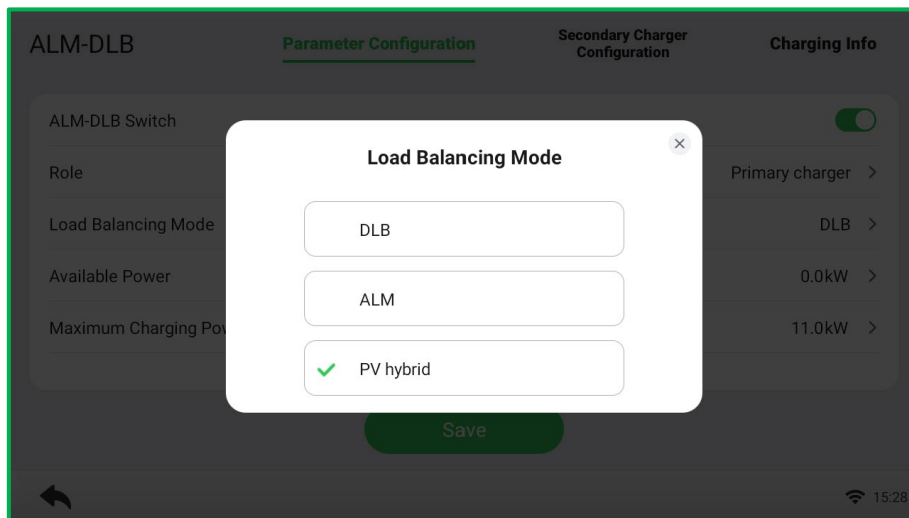

There are three charging modes available. The settings vary depending on the charging modes.

a) Full Green Charging Mode

- ✓ **Charging Mode:** Select **Full Green** from the charging mode options.
- ✓ **Meter Type:** Select the meter from the meter type options.
- ✓ **Maximum Charging Power of Charger:** lower than the rated power of the charger.
- ✓ **Charging Power for Offline Meter:** the default charging power for offline meter is 10% of the available power.

Tap **Save** once you have completed the settings.

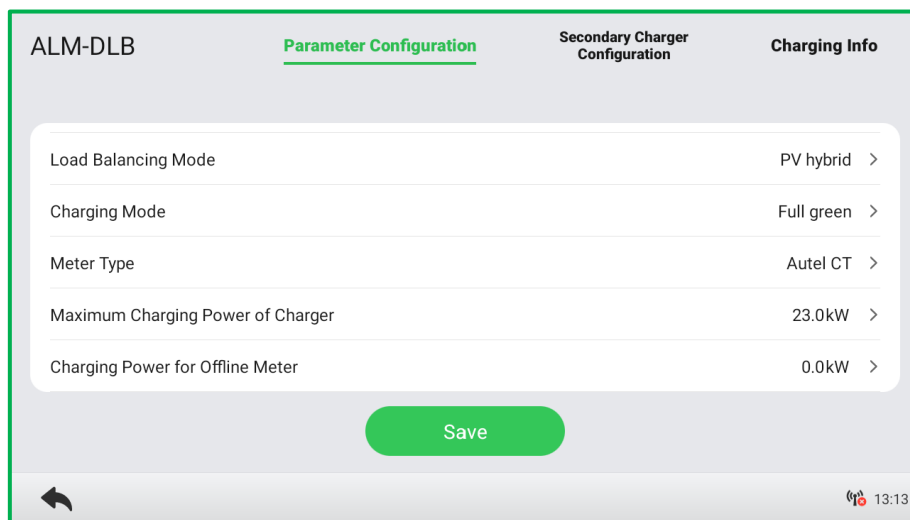
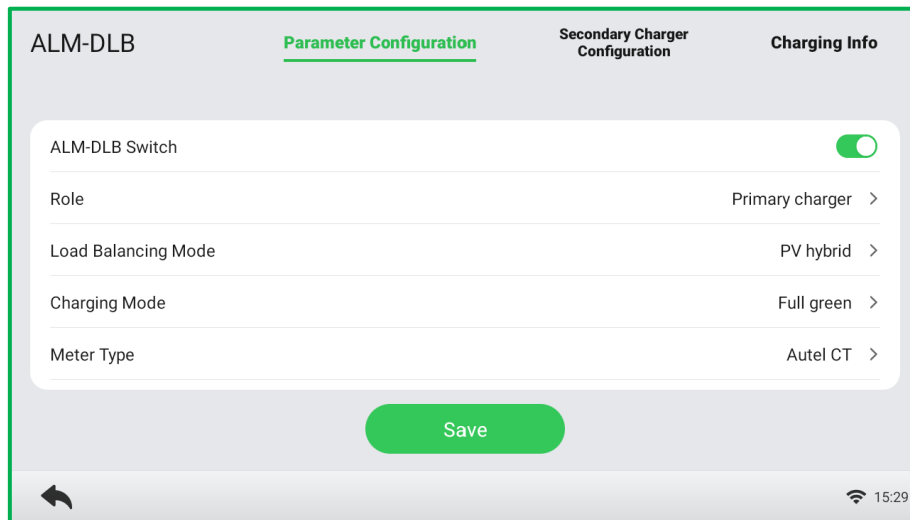

b) Green Priority Charging Mode

- ✓ **Charging Mode:** Select **Green Priority** from the charging mode options.
- ✓ **Available Power (kW):** you need to enter the available power that the system can supply to the chargers. You must enter a whole number.

The value of the available power should be within the following range:

- ◆ **Maximum Value:** lower than the upstream MCB/RCBO rated power.
- ◆ **Minimum Value:** higher than the minimum power of one charger (1.4 kW for single-phase, 4.2 kW for three-phase) x N (N represents the number of chargers in the device group).

- ✓ **Meter Type:** Select the meter from the meter type options.
- ✓ **Maximum Charging Power of Charger (kW):** lower than the rated power of the charger.
- ✓ **Minimum Charging Power (kW):** the sum of the minimum charging power of all chargers.
- ✓ **Charging Power for Offline Meter (kW):** the default charging power for offline meter is 10% of the available power.

Tap **Save** once you have completed the settings.

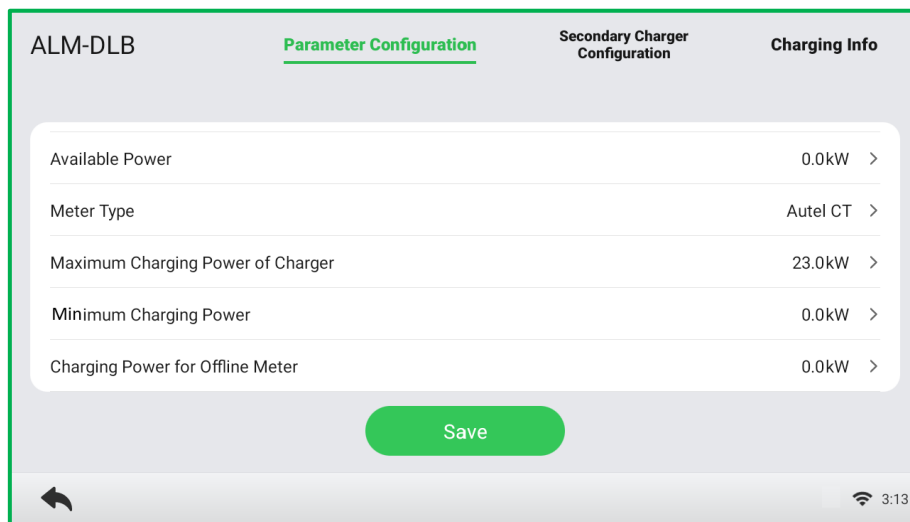
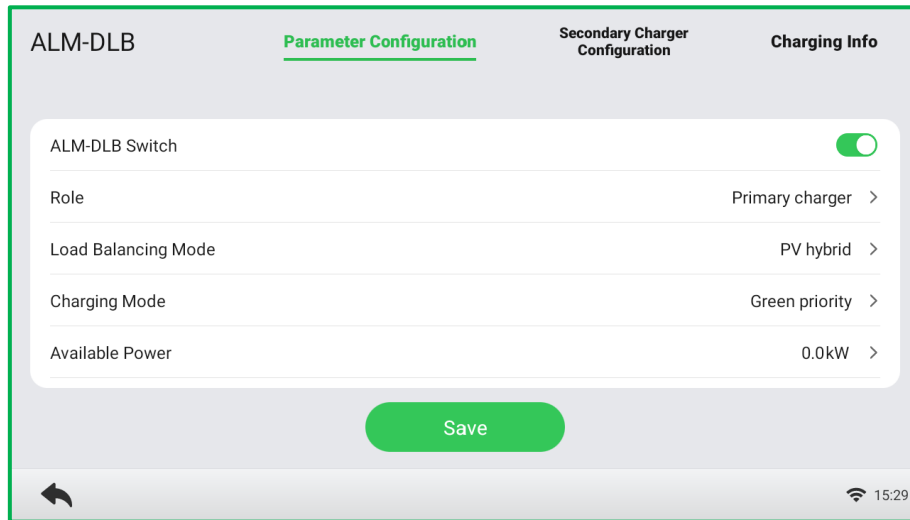

c) Speed Priority Charging Mode

- ✓ **Charging Mode:** Select **Speed Priority** from the charging mode options.
- ✓ **Available Power (kW):** you need to enter the available power that the system can supply to the chargers. You must enter a whole number.

The value of the available power should be within the following range:

- ◆ **Maximum Value:** lower than the upstream MCB/RCBO rated power.
- ◆ **Minimum Value:** higher than the minimum power of one charger (1.4 kW for single-phase, 4.2 kW for three-phase) x N (N represents the number of chargers in the device group).

- ✓ **Meter Type:** Select the meter from the meter type options.
- ✓ **Maximum Charging Power of Charger(kW):** lower than the rated power of the charger.
- ✓ **Charging Power for Offline Meter (kW):** the default charging power for offline meter is 10% of the available power.

Tap **Save** once you have completed the settings.

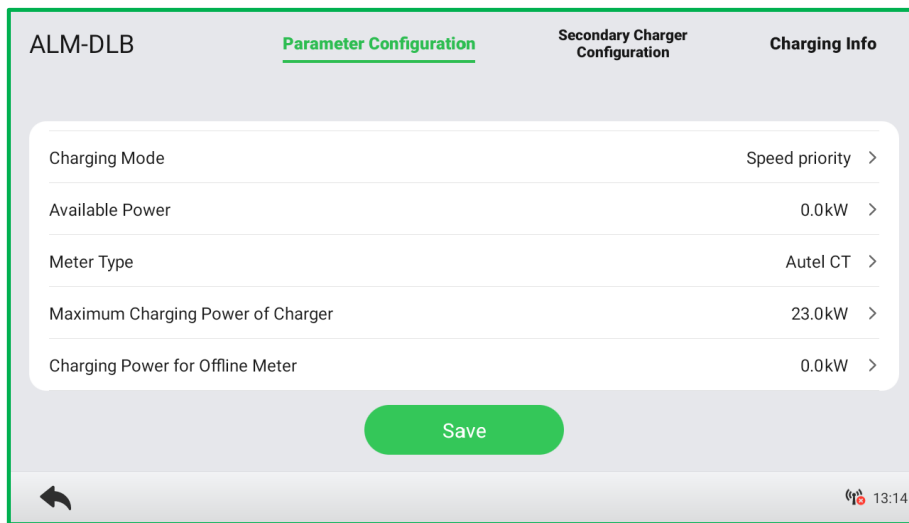
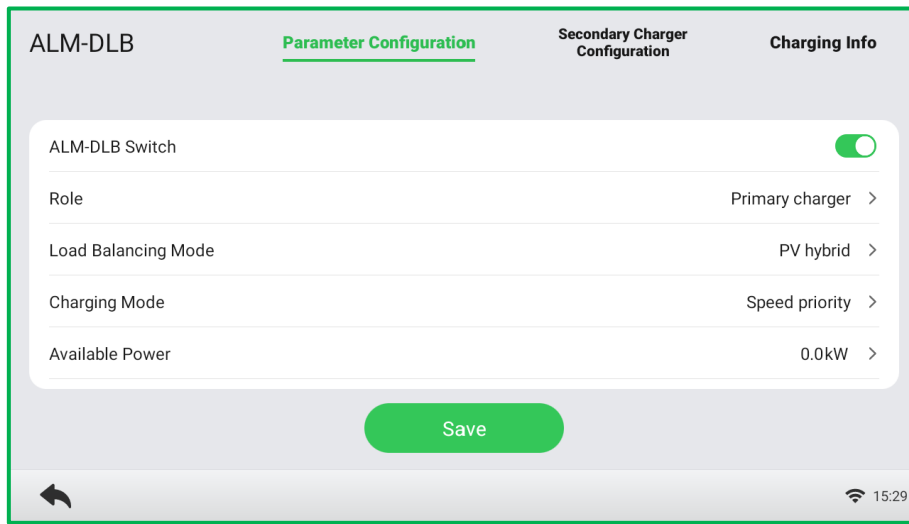

4. **Confirm configuration.** After all the setups above are completed, tap on **Charging Information** to confirm the configuration of the selected operating mode.

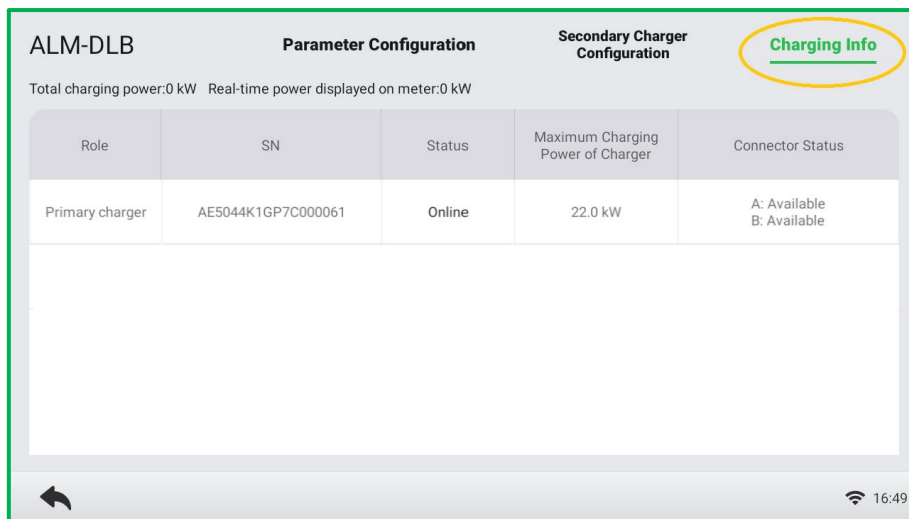

4.2.1.5 Set up PV Hybrid Mode w/Multiple Chargers

1. Refer to **STEP 1-4** in 3.3.4 to enter the **Device Maintenance** screen and select **ALM-DLB**.
2. **Set secondary charger.**
 - 1) Enable **ALM-DLB Switch** as shown below.
 - 2) Click on “>” to the right of the **Role** and select **Secondary charger**.

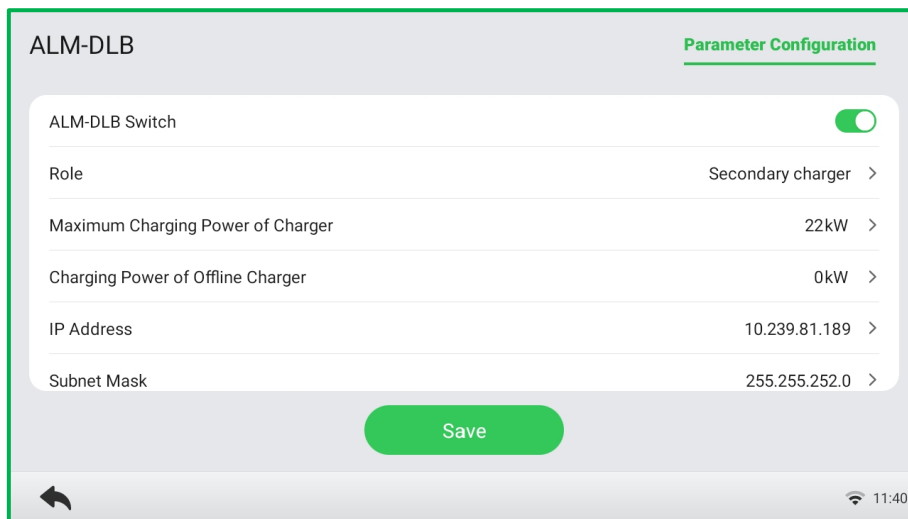

- 3) Configure the parameters of **Maximum Charging Power of Charger** and **Charging Power of Offline Charger**.
 - ✓ **Maximum Charging Power of Charger (kW)**: lower than the rated power of the charger.
 - ✓ **Charging Power of Offline Charger (kW)**: this value is 0 by default.

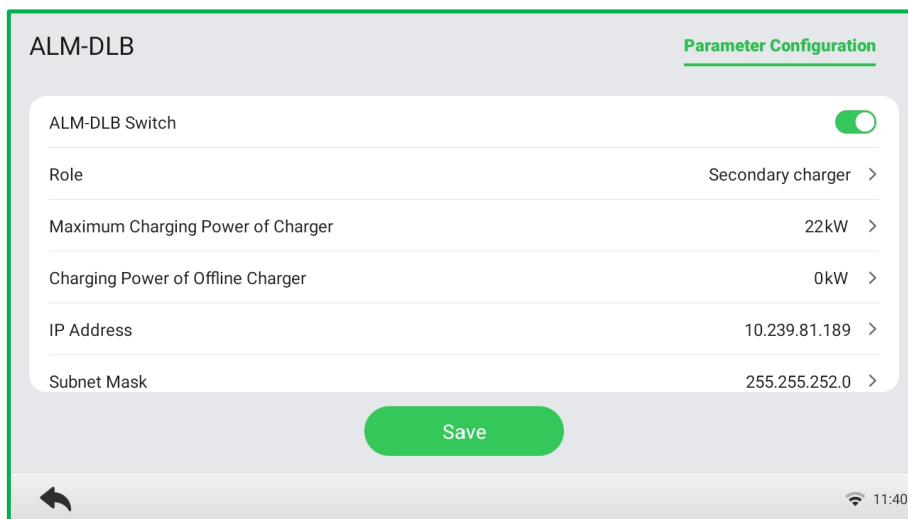

- 4) **Record the IP Address** for the follow-up configuration and click on the **Save** button to save the setup.
- 5) Set the remaining secondary chargers and configure their parameters successively according to the previous steps.

3. Set primary charger.

- 1) Refer to **STEP 1-4** in [3.3.4](#) to enter the **Device Maintenance** screen and select **ALM-DLB**.
- 2) Enable **ALM-DLB Switch** as shown below.
- 3) Click on “>” to the right of the **Role** and select **Primary charger**.

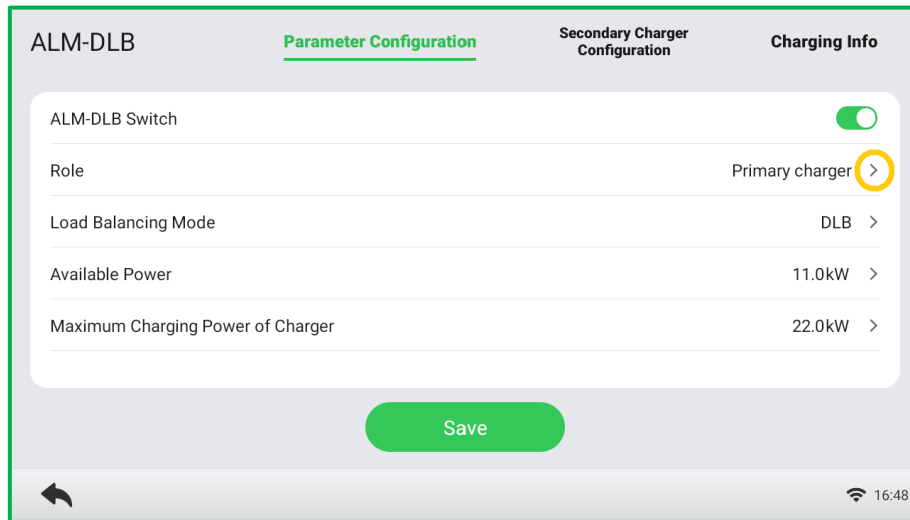

4. Set up PV Hybrid mode. Click on “>” to the right of the Load Balancing Mode and select PV Hybrid.

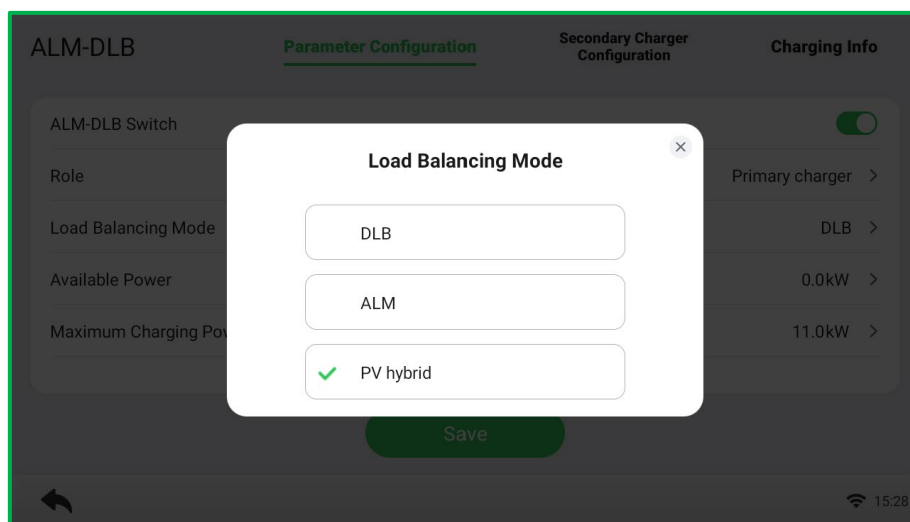

There are three charging modes available. The settings vary depending on the charging modes.

a) Full Green Charging Mode

- ✓ **Charging Mode:** Select **Full Green** from the charging mode options.
- ✓ **Meter Type:** Select the meter from the meter type options.
- ✓ **Maximum Charging Power of Charger:** lower than the rated power of the charger.
- ✓ **Charging Power for Offline Meter:** the default charging power for offline meter is 10% of the available power.

Tap **Save** once you have completed the settings.

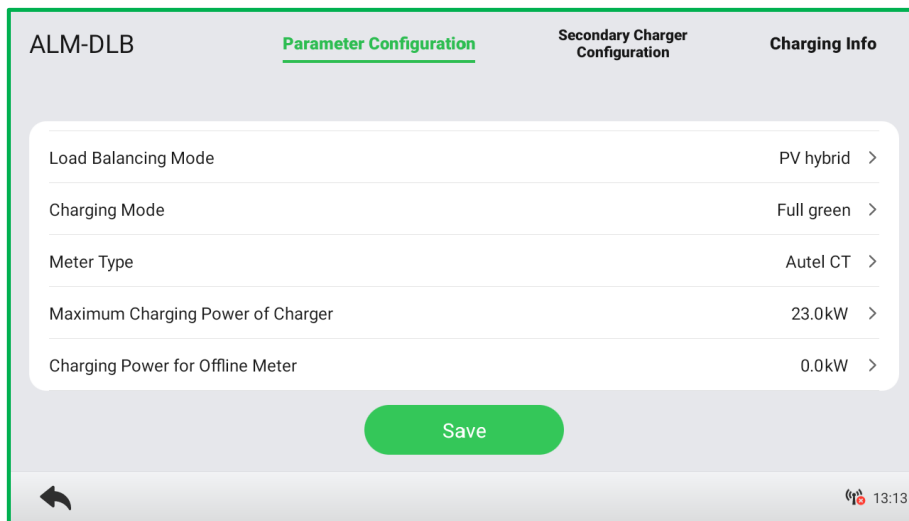
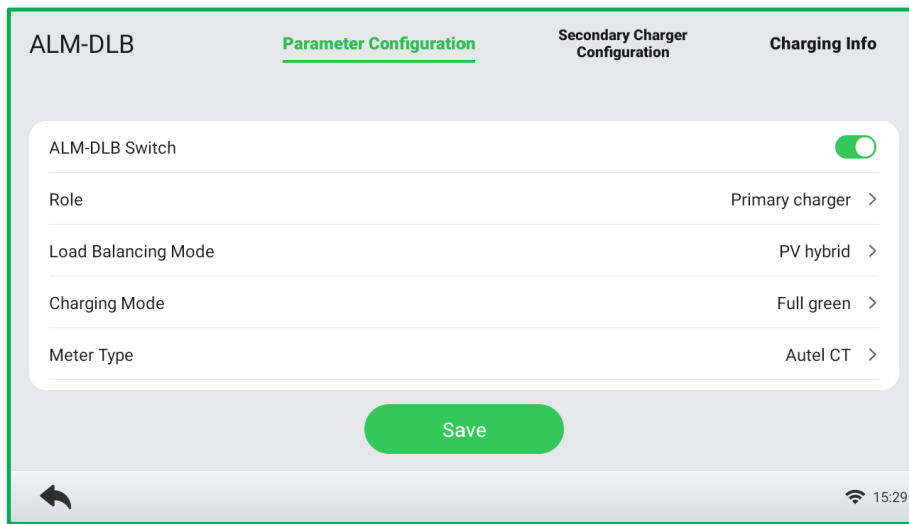

b) Green Priority Charging Mode

- ✓ **Charging Mode:** Select **Green Priority** from the charging mode options.
- ✓ **Available Power (kW):** you need to enter the available power that the system can supply to the chargers. You must enter a whole number.

The value of the available power should be within the following range:

- ◆ **Maximum Value:** lower than the upstream MCB/RCBO rated power.
- ◆ **Minimum Value:** higher than the minimum power of one charger (1.4 kW for single-phase, 4.2 kW for three-phase) x N (N represents the number of chargers in the device group).

- ✓ **Meter Type:** Select the meter from the meter type options.
- ✓ **Maximum Charging Power of Charger (kW):** lower than the rated power of the charger.
- ✓ **Minimum Charging Power (kW):** the sum of the minimum charging power of all chargers.
- ✓ **Charging Power for Offline Meter (kW):** the default charging power for offline meter is 10% of the available power.

Tap **Save** once you have completed the settings.

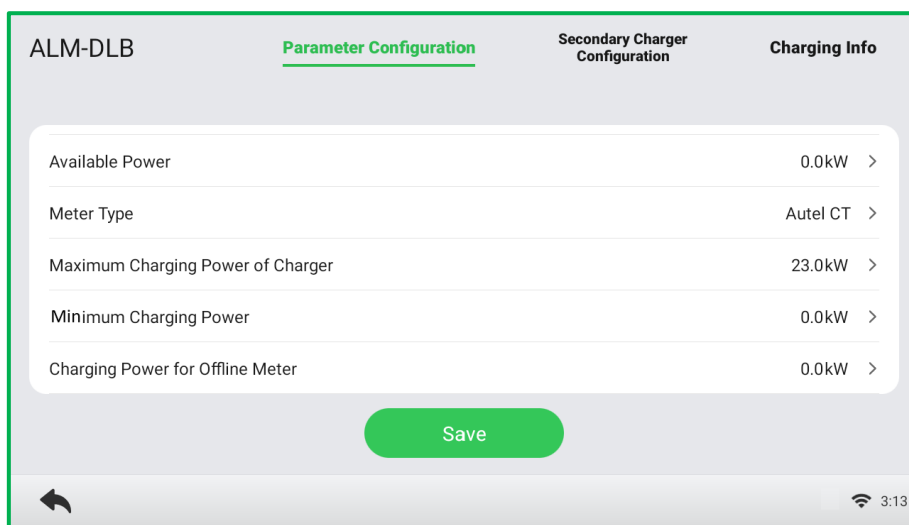
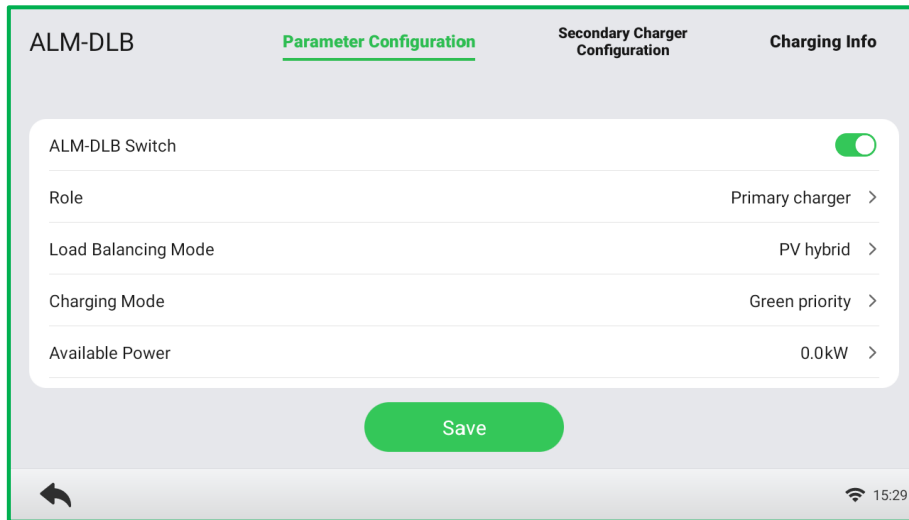

c) Speed Priority Charging Mode

- ✓ **Charging Mode:** Select **Speed Priority** from the charging mode options.
- ✓ **Available Power (kW):** you need to enter the available power that the system can supply to the chargers. You must enter a whole number.

The value of the available power should be within the following range:

- ◆ **Maximum Value:** lower than the upstream MCB/RCBO rated power.
- ◆ **Minimum Value:** higher than the minimum power of one charger (1.4 kW for single-phase, 4.2 kW for three-phase) x N (N represents the number of chargers in the device group).

- ✓ **Meter Type:** Select the meter from the meter type options.
- ✓ **Maximum Charging Power of Charger(kW):** lower than the rated power of the charger.
- ✓ **Charging Power for Offline Meter (kW):** the default charging power for offline meter is 10% of the available power.

Tap **Save** once you have completed the settings.

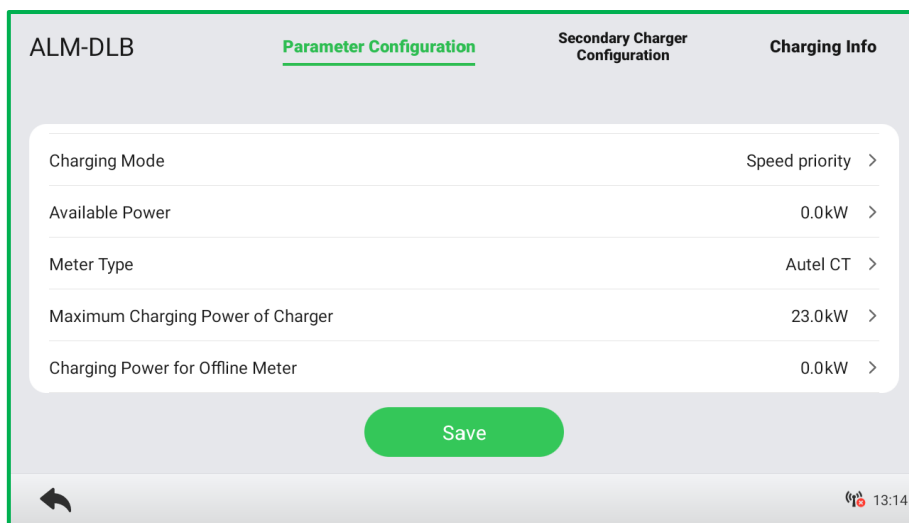
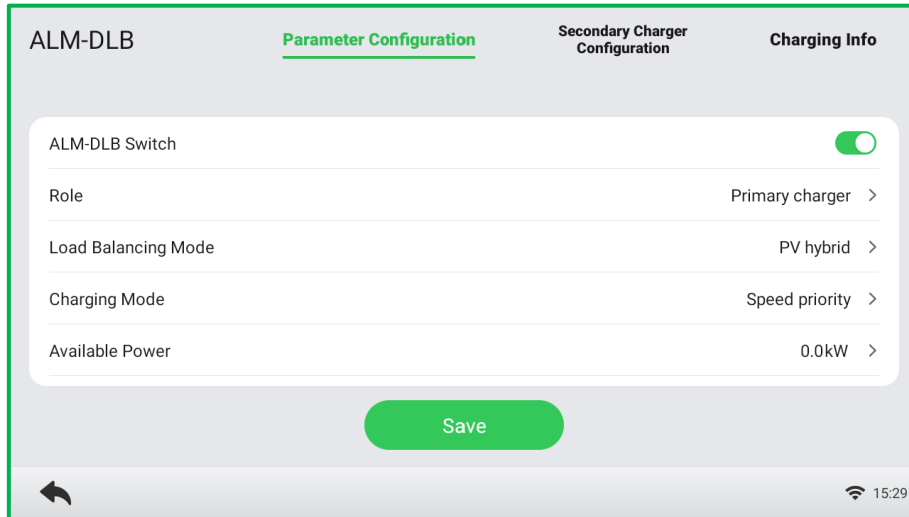

5. **Add secondary charger.** Tap on **Secondary Charger Configuration** and click on **Add Secondary Charger**. Add the secondary charger by inputting the recorded IP address and click on the **Save** button to save the setup.

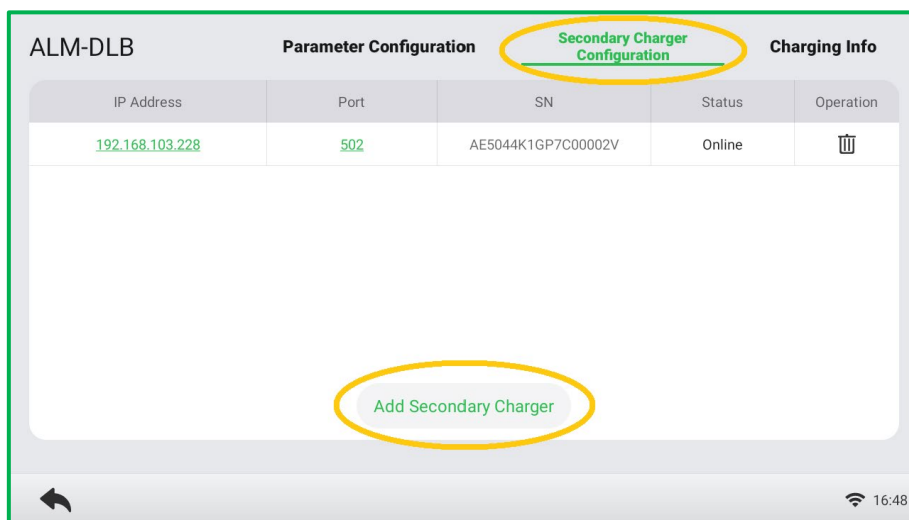

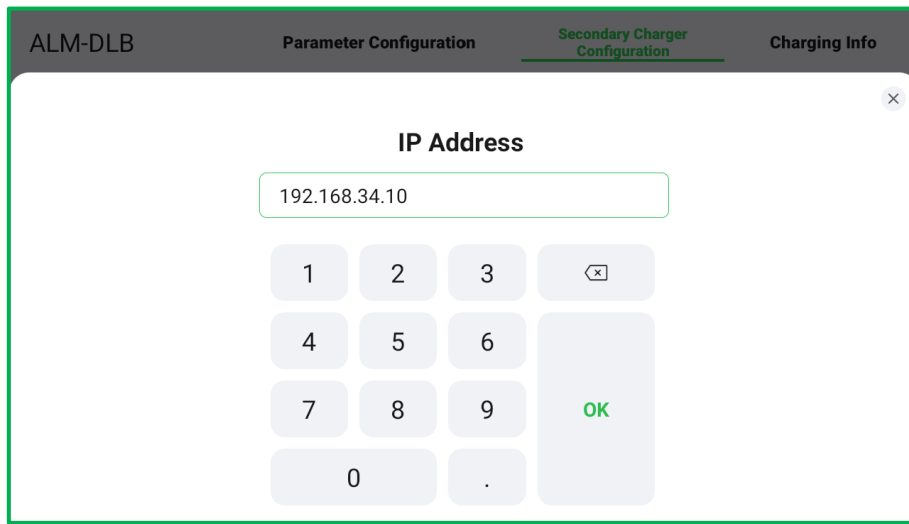

6. **Confirm configuration.** After all the setups above are completed, tap on **Charging Information** to confirm the configuration of the selected operating mode.

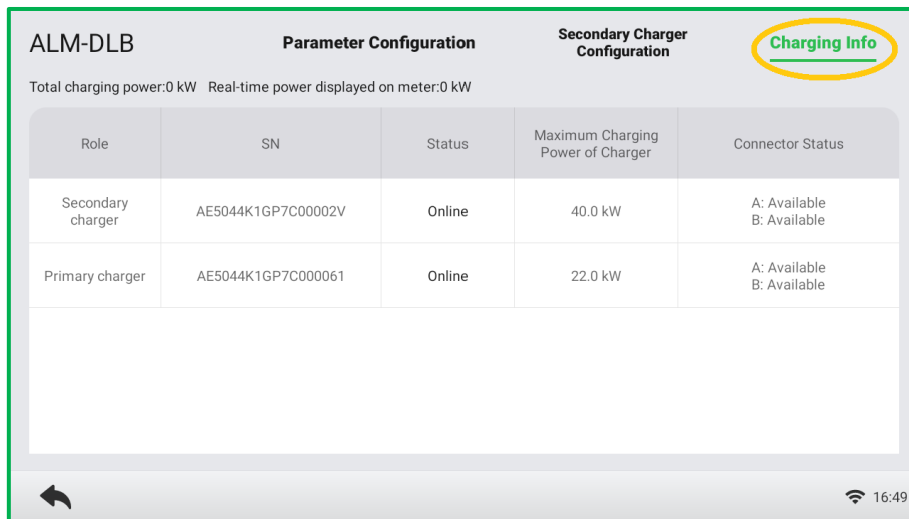

4.2.1.6 Set up EMS Mode

1. Refer to **STEP 1-4** in [3.3.4](#) to enter the **Device Maintenance** screen.
2. On the Device Maintenance screen, select **Modbus**.

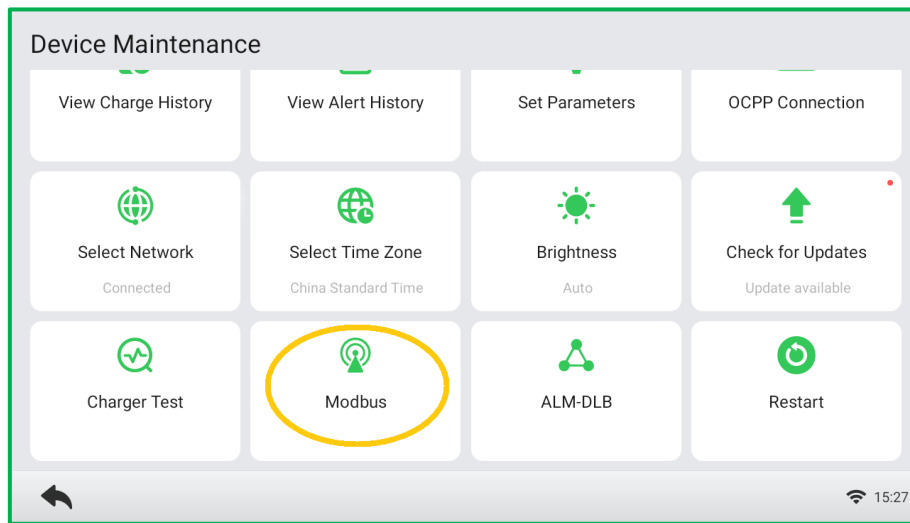

3. Toggle the **Modbus Communication ON**.

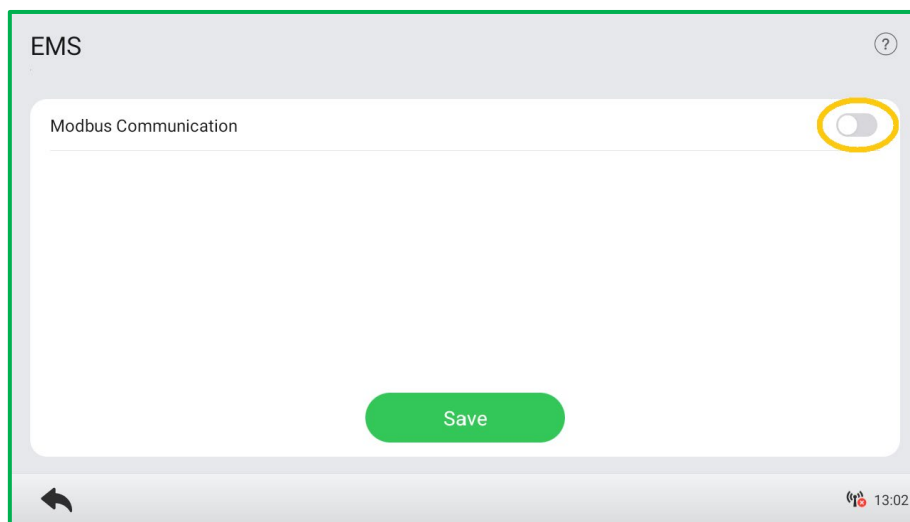

4. **Select a connection mode.** The charger can be connected to the EMS as TCP server or TCP client. Select a connection mode based on the scenarios.

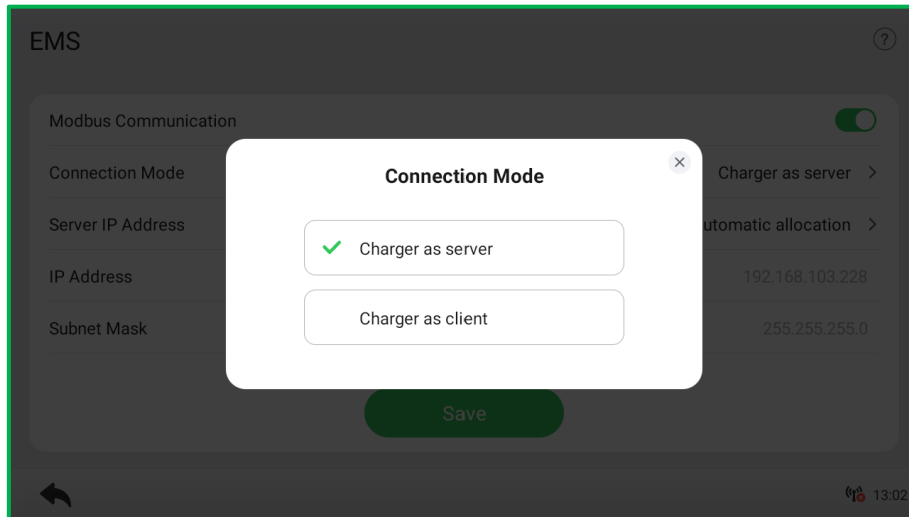

- ✓ If the charger is used as a TCP server, it acts as a host, waiting for the EMS to establish a connection and send requests or data. Select **Charger as server** to continue.
- ◆ Choose the desired method to access the IP address after selecting the Charger as server mode: **automatic** or **manual**. The automatic method allows for automatic retrieval of the IP address, subnet mask, and gateway. On the other hand, the manual method requires manual input of these details.

When choose the manual method, obtain the IP Address, Subnet Mask, and Default Gateway of the charger by following the steps below:

- 1) Connect your personal computer to the Wi-Fi of the router (or connect one end of an Ethernet cable to your personal computer and the other end to the router).
- 2) Launch the browser on the computer and enter the URL of the router to log in to the web console.
- 3) Check and record the IP Address of the charger for the follow-up configuration.

Input the port number and tap **Save** to finish the setup.

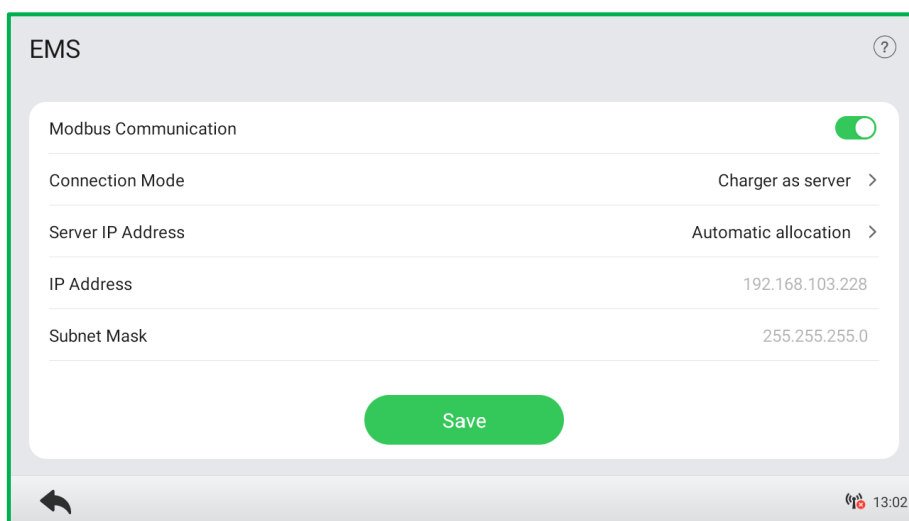

EMS ?

Server IP Address Automatic allocation >

IP Address 192.168.103.228

Subnet Mask 255.255.255.0

Default Gateway 192.168.100.1

Port 502 >

[Save](#)

13:03

EMS ?

Server IP Address Manual setting >

IP Address 192.168.103.228 >

Subnet Mask 255.255.255.0 >

Default Gateway 192.168.100.1 >

Port 502 >

[Save](#)

13:03

- ✓ If the charger is used as a TCP client, it initiates the connection to the EMS. Select **Charger as client** to continue. Input the server IP address and port number, then tap **Save** to finish the setup.

EMS ?

Modbus Communication

Connection Mode Charger as client >

Server IP Address 192.168.1.150 >

Port 502 >

[Save](#)

13:02

NOTE
The Modbus TCP server port is 502 by default.

4.2.2 For Scenarios with Chargers of Different Models

Follow the steps below to activate the operating modes for the following scenarios:

- AC Ultra + AC Wallbox/AC Compact
- DC Compact/DC Fast + AC Wallbox/AC Compact

4.2.2.1 Set up DLB Mode

1. Refer to 3.3.3 to configure secondary chargers (AC Wallbox/AC Compact).
2. **Start setting.** Tap **Account > Charger**. Select the charger from the chargers list, then tap **Load Balancing > Connect to EMS**. A brief description about this mode will appear on the screen. Tap **Start Setting** to continue.

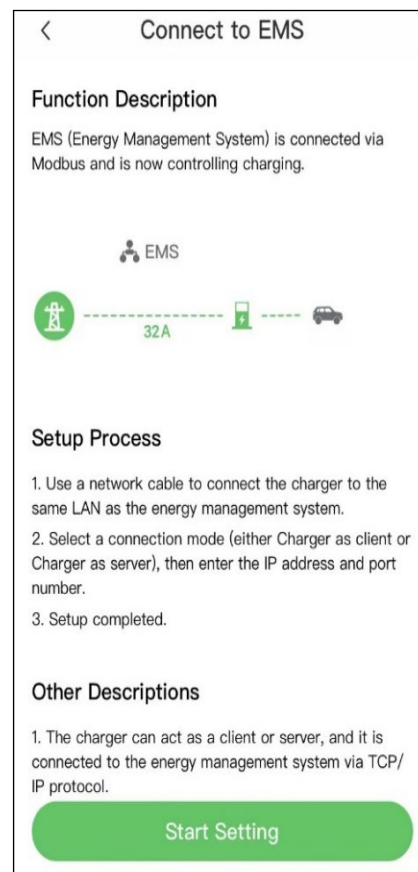
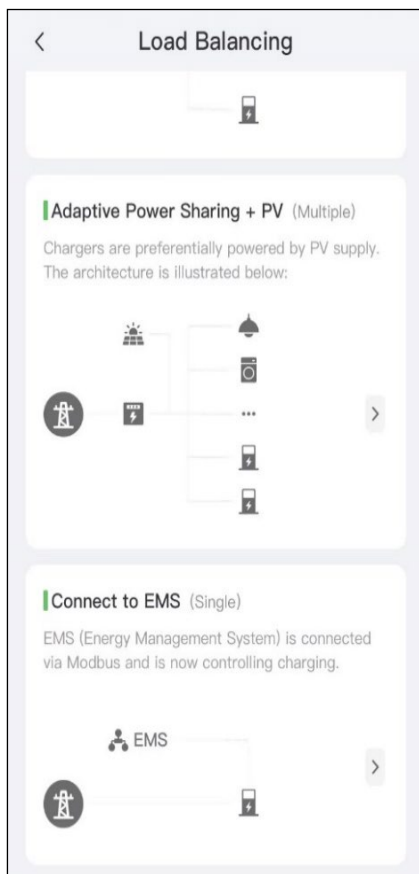

3. Set the Connection Mode to **Charger as server**. Choose **Manual** method to access the IP Address and input the IP Address, Subnet Mask, Default Gateway, and Server Port.

Obtain the IP Address, Subnet Mask, and Default Gateway of the charger by following the steps below:

- 1) Connect your personal computer to the Wi-Fi of the router (or connect one end of an Ethernet cable to your personal computer and the other end to the router).
- 2) Launch the browser on the computer and enter the URL of the router to log in to the web console.
- 3) Check and record the IP Address, Subnet Mask, and Default Gateway of the charger for the follow-up configuration.

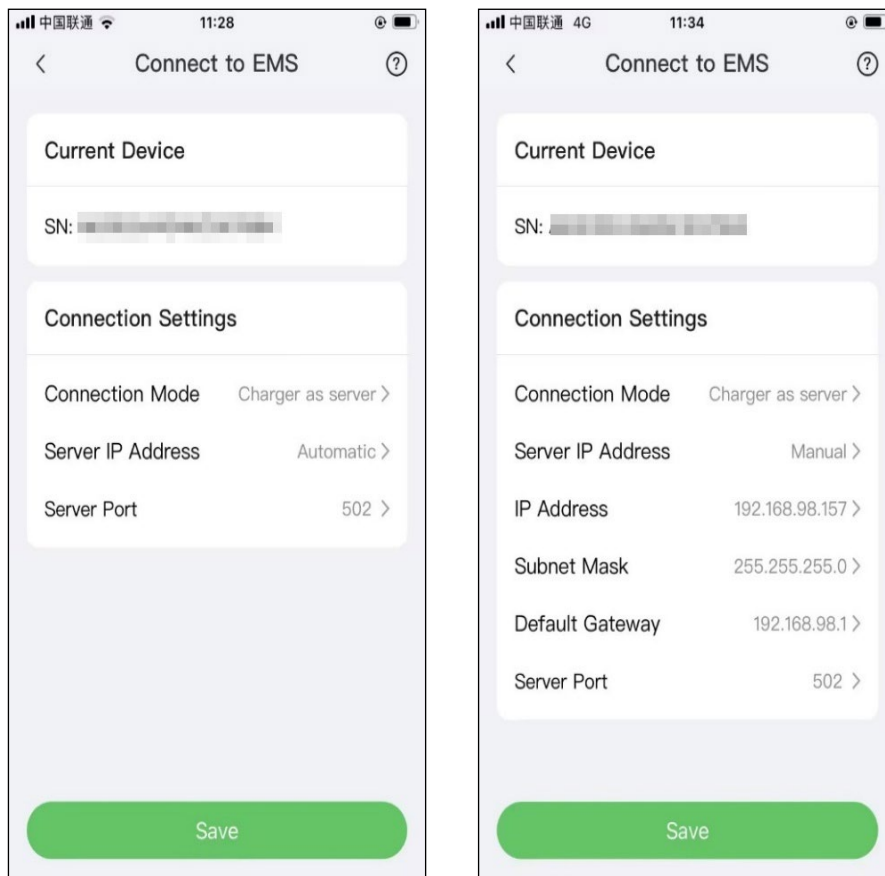

NOTE

The Modbus TCP server port is 502 by default.

4. **Record the IP Address** for the follow-up configuration and tap **Save** to finish the setup.

- Confirm configuration.** Tap the “<” icon on the upper-left corner of the Connect to EMS screen to return to the **Load Balancing** screen. The **Enabled** tag will appear on this mode, indicating that the charger has been successfully connected to the EMS.

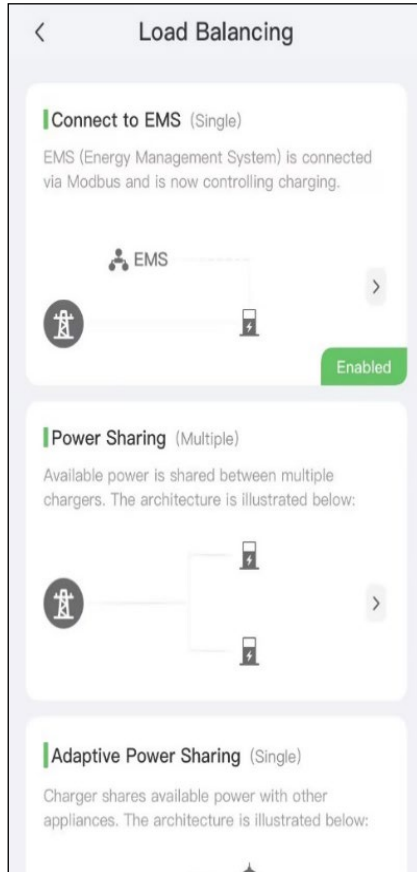

6. Set primary charger.

- 1) Refer to **STEP 1-4** in [3.3.4](#) to enter the **Device Maintenance** screen and select **ALM-DLB**.
- 2) Enable **ALM-DLB Switch** as shown below.
- 3) Click on “>” to the right of the **Role** and select **Primary charger**.

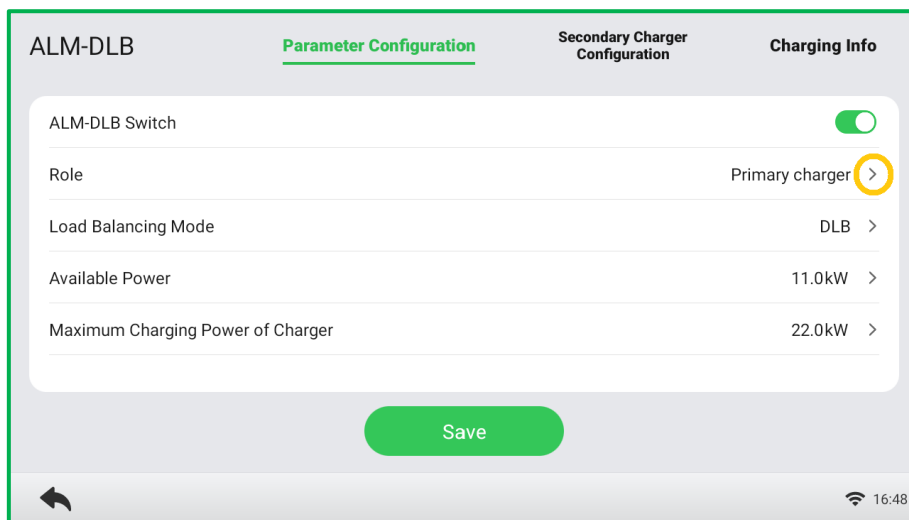

7. Set up DLB mode.

- 1) Click on “>” to the right of the **Load Balancing Mode** and select **DLB**.

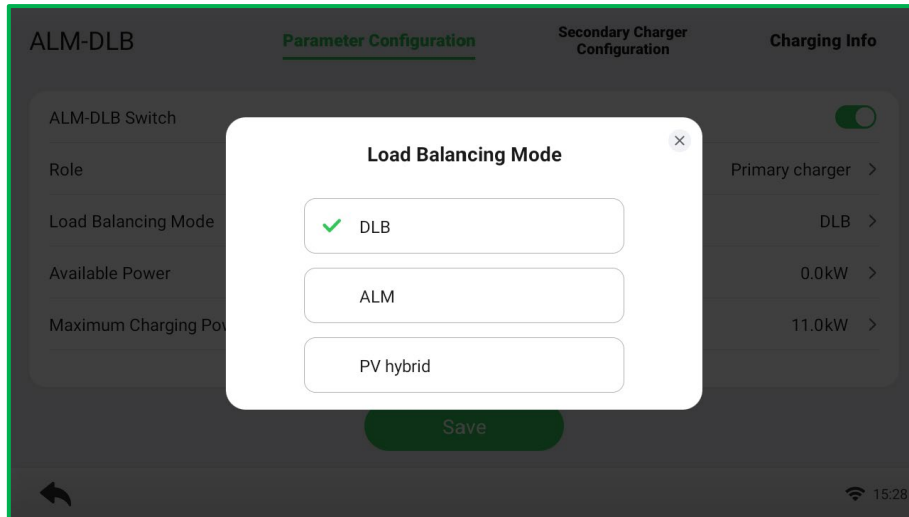

- 2) Configure the parameters of **Available Power** and **Maximum Charging Power of Charger**.

- ✓ **Available Power (kW):** You must enter the available power that the system can supply to the chargers. This value must be expressed as a whole number.

The value of the available power should be within the following range:

- ◆ **Maximum Value:** lower than the upstream MCB/RCBO rated power.
- ◆ **Minimum Value:** higher than the minimum power of one charger (1.4 kW for single-phase, 4.2 kW for three-phase) x N (N represents the number of chargers in the device group).

- ✓ **Maximum Charging Power of Charger:** lower than the rated power of the charger.

Click on the **Save** button to save the settings.

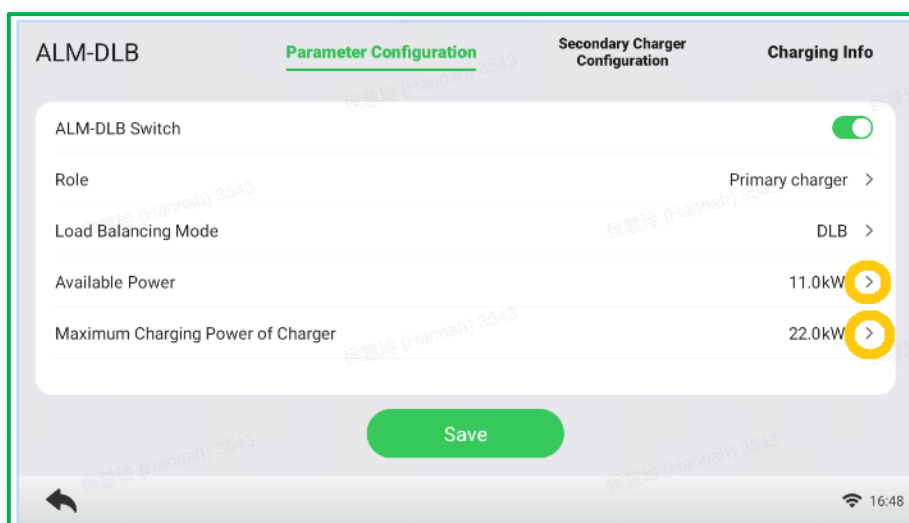

- Add secondary charger.** Tap on **Secondary Charger Configuration** and click on **Add Secondary Charger**. Add the secondary charger by inputting the recorded IP address and click on the **Save** button to save the setup.

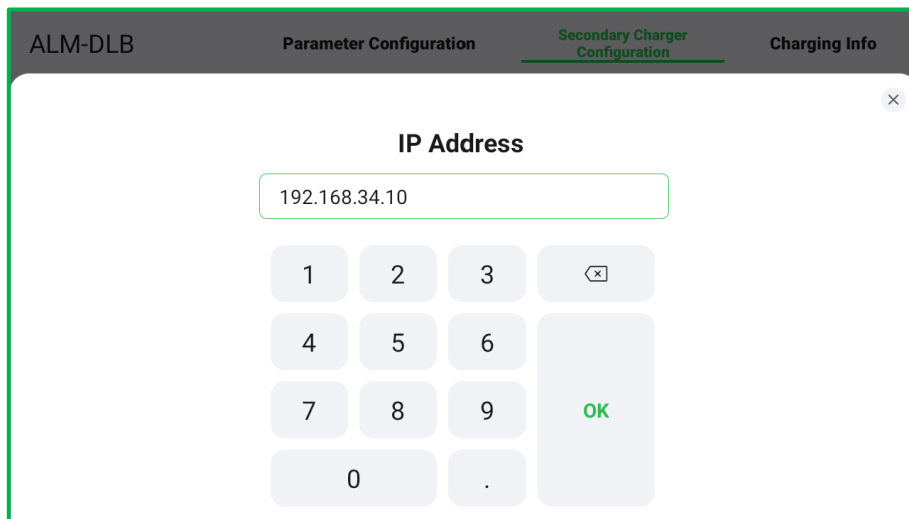
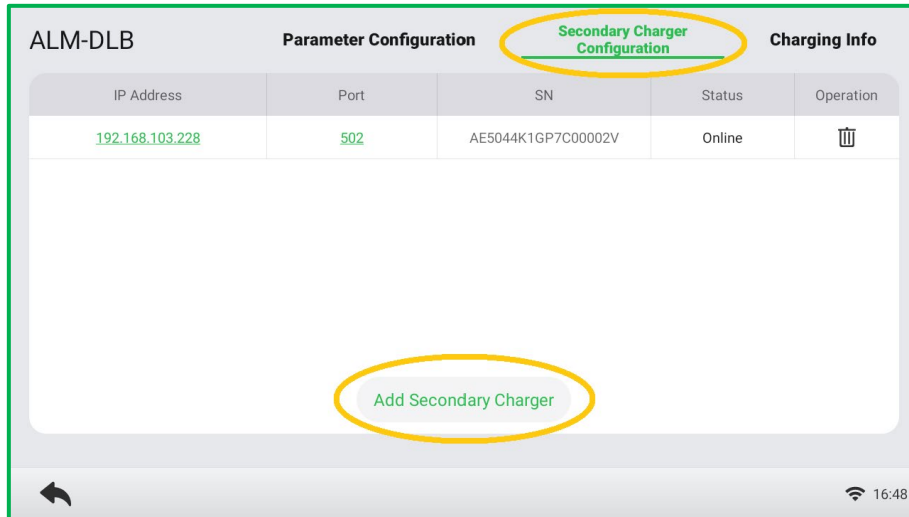

- Confirm configuration.** After all the setups above are completed, tap on **Charging Information** to confirm the configuration of the selected operating mode.

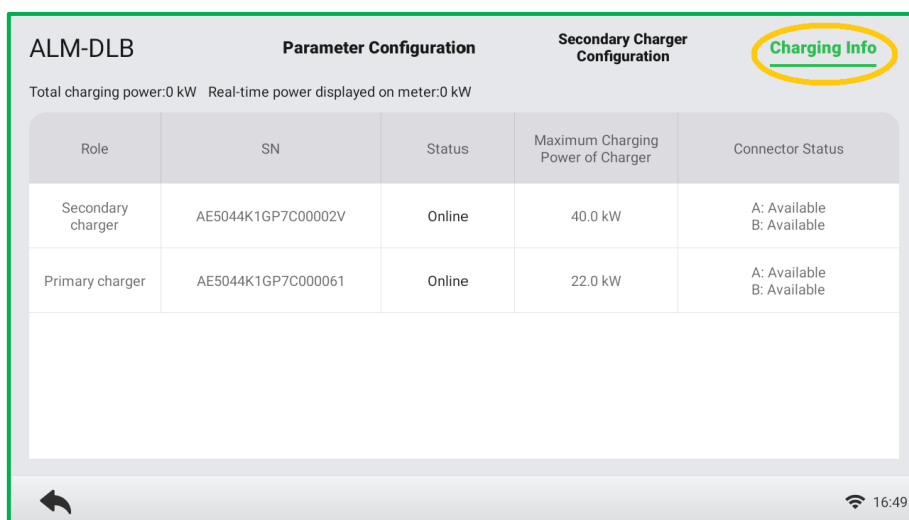

4.2.2.2 Set up ALM Mode w/Multiple Chargers

1. Refer to **STEP 1-5** in [4.2.2.1](#) to configure secondary chargers (AC Wallbox/AC Compact) to EMS mode.
2. Set primary charger.
 - 1) Refer to **STEP 1-4** in [3.3.4](#) to enter the **Device Maintenance** screen and select **ALM-DLB**.
 - 2) Enable **ALM-DLB Switch** as shown below.
 - 3) Click on “>” to the right of the **Role** and select **Primary charger**.

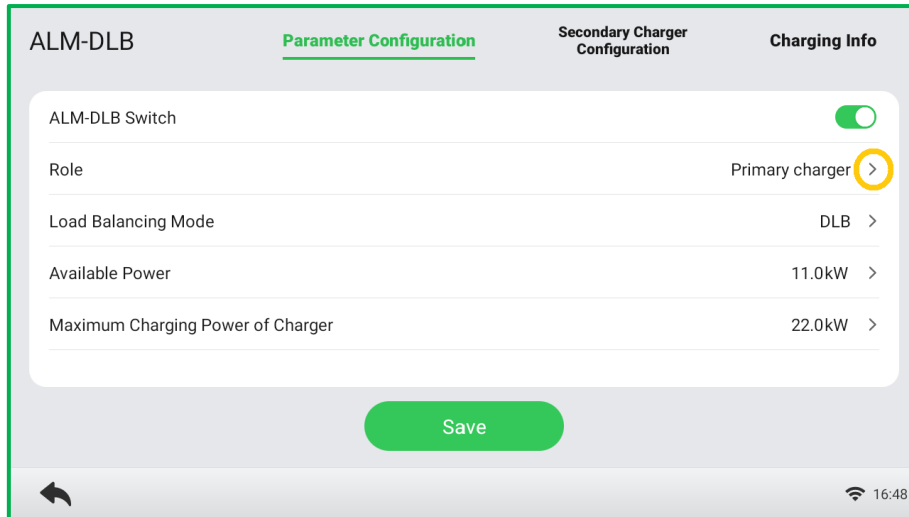

3. Set up ALM mode.

- 1) Click on “>” to the right of the **Load Balancing Mode** and select **ALM**.

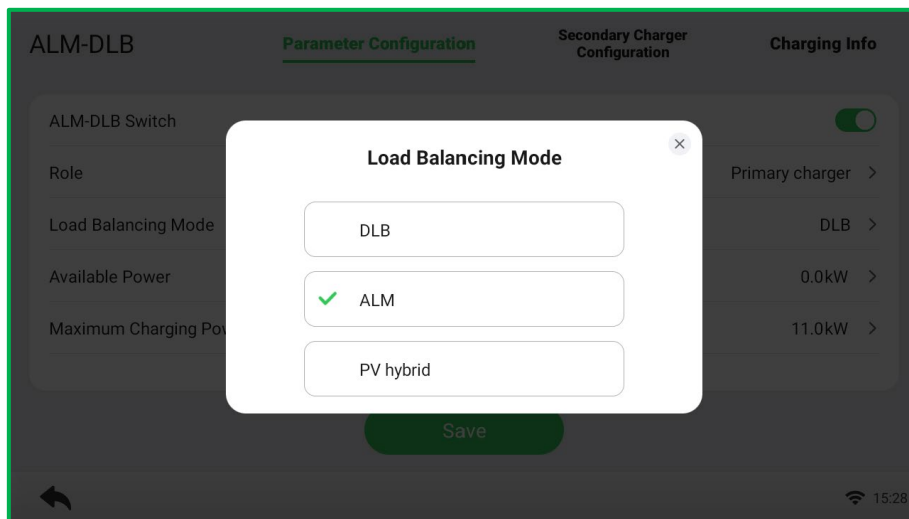

2) Click on “>” to the right of the **Meter Type** and select the meter.

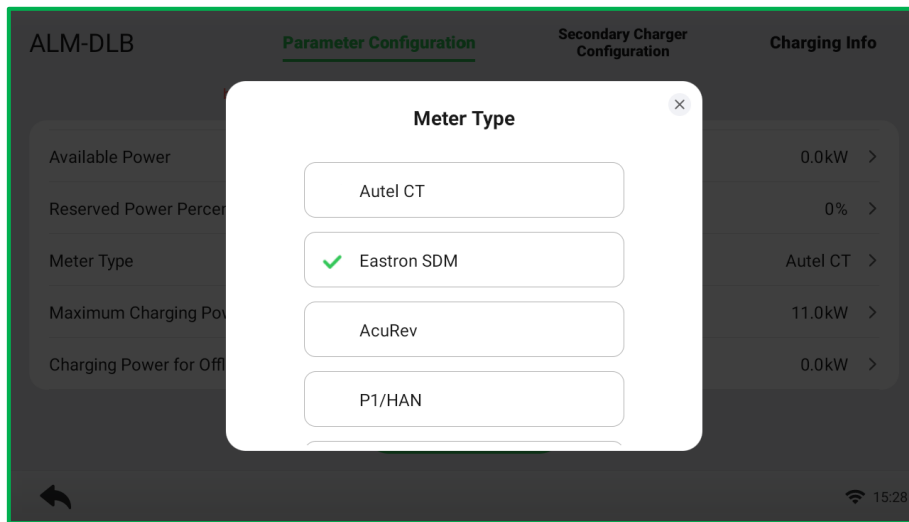

3) Configure the parameters of **Available Power**, **Reserved Power Percentage**, **Maximum Charging Power of Charger**, and **Charging Power for Offline Meter**.

- ✓ **Available Power (kW):** you need to enter the available power that the system can supply to the chargers. You must enter a whole number.

The value of the available power should be within the following range:

- ◆ **Maximum Value:** lower than the upstream MCB/RCBO rated power.
- ◆ **Minimum Value:** higher than the minimum power of one charger (1.4 kW for single-phase, 4.2 kW for three-phase) x N (N represents the number of chargers in the device group).

- ✓ **Reserved Power Percentage:** you must enter the power reserve for the charger, namely the reserved power not used for charging.

- ◆ The range of the power reserve is from 0–50%. The maximum reserved power that can be entered is 50% of the total home power.
- ◆ The default setting of the power reserve is 10%, which is used for the dynamic power change caused by load switching in and out.

- ✓ **Maximum Charging Power of Charger:** lower than the rated power of the charger.
- ✓ **Charging Power for Offline Meter:** the default charging power for offline meter is 10% of the available power.

Click on the **Save** button to save the settings.

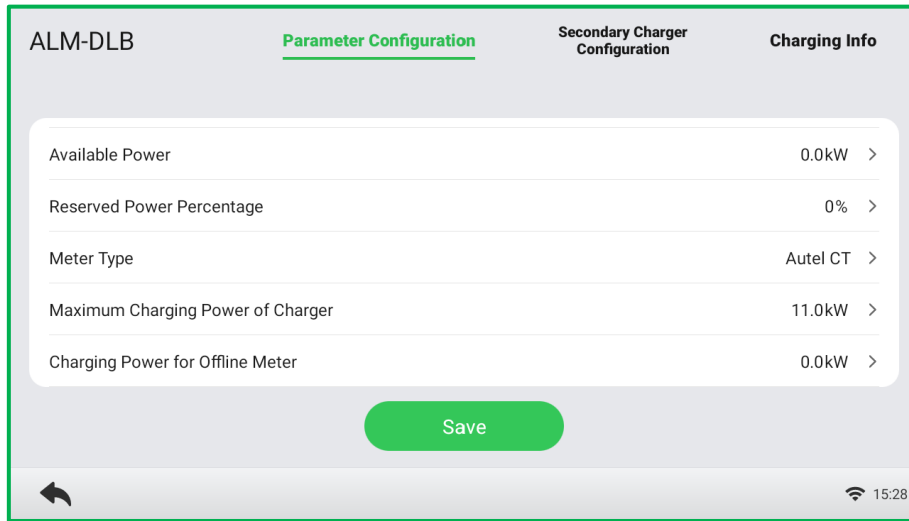

4. **Add secondary charger.** Tap on **Secondary Charger Configuration** and click on **Add Secondary Charger**. Add the secondary charger by inputting the recorded IP address and click on the **Save** button to save the setup.

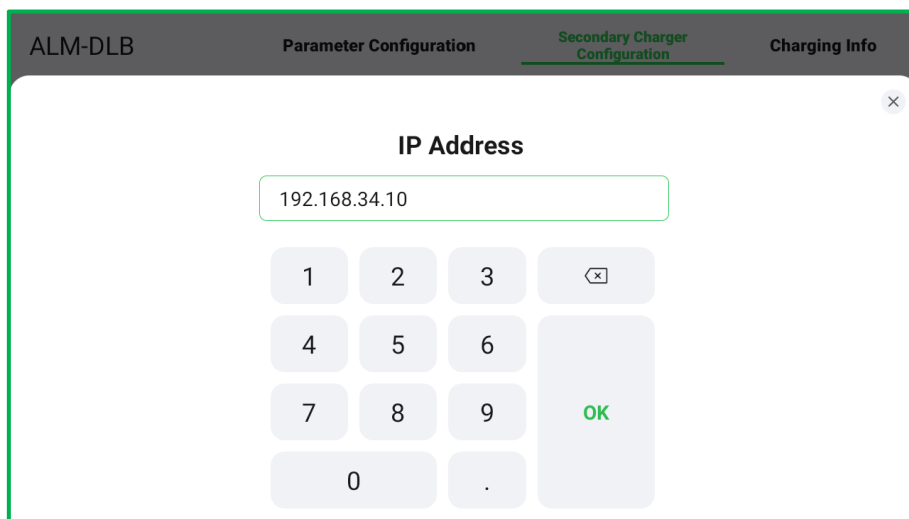
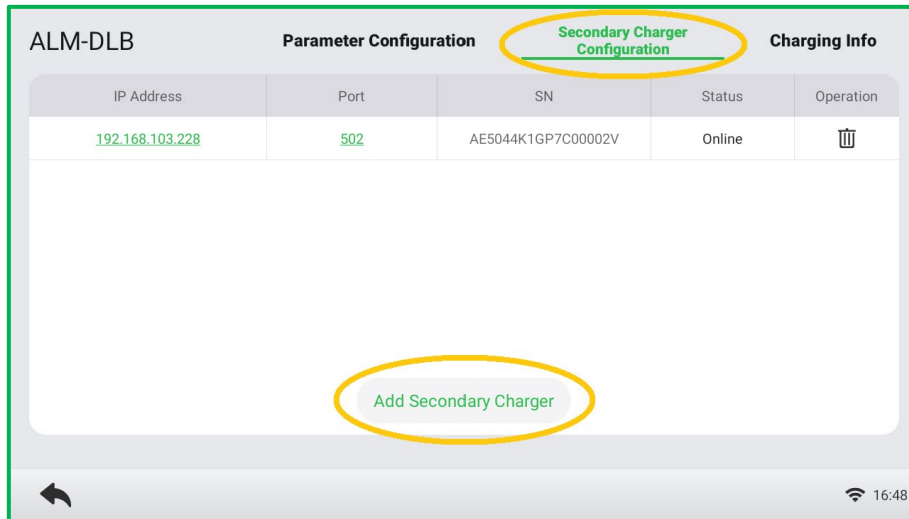

5. **Confirm configuration.** After all the setups above are completed, tap on **Charging Information** to confirm the configuration of the selected operating mode.

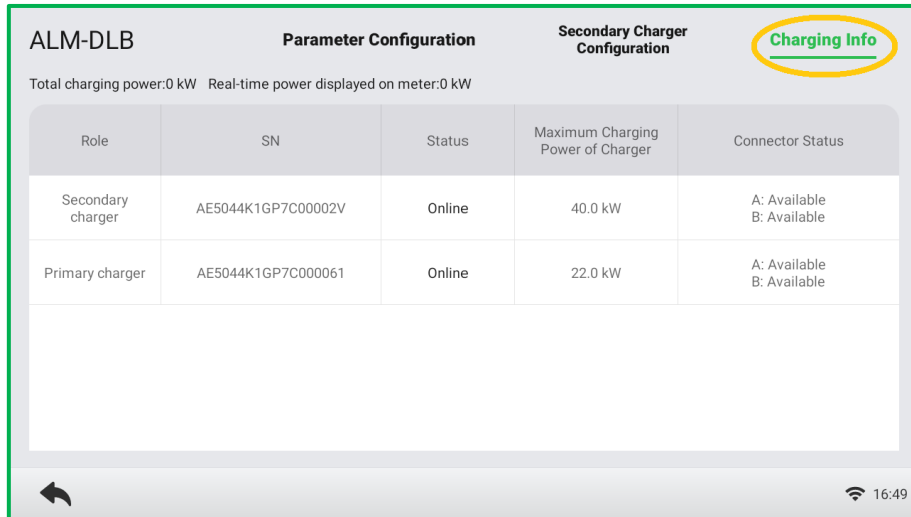

4.2.2.3 Set up PV Hybrid Mode w/Multiple Chargers

1. Refer to **STEP 1-5** in [4.2.2.1](#) to configure secondary chargers (AC Wallbox/AC Compact) to EMS mode.
2. **Set primary charger.**
 - 1) Refer to **STEP 1-4** in [3.3.4](#) to enter the **Device Maintenance** screen and select **ALM-DLB**.
 - 2) Enable **ALM-DLB Switch** as shown below.
 - 3) Click on “>” to the right of the **Role** and select **Primary charger**.

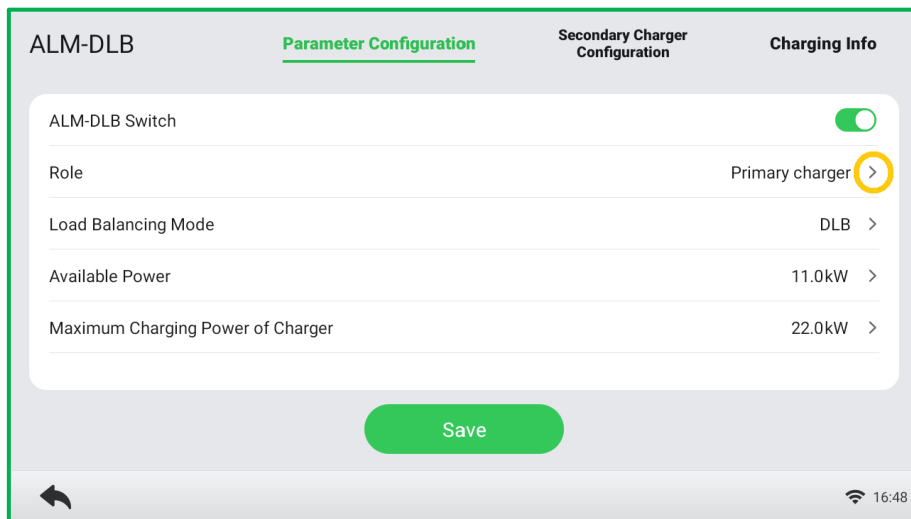

3. **Set up PV Hybrid mode.** Click on “>” to the right of the **Load Balancing Mode** and select **PV Hybrid**.

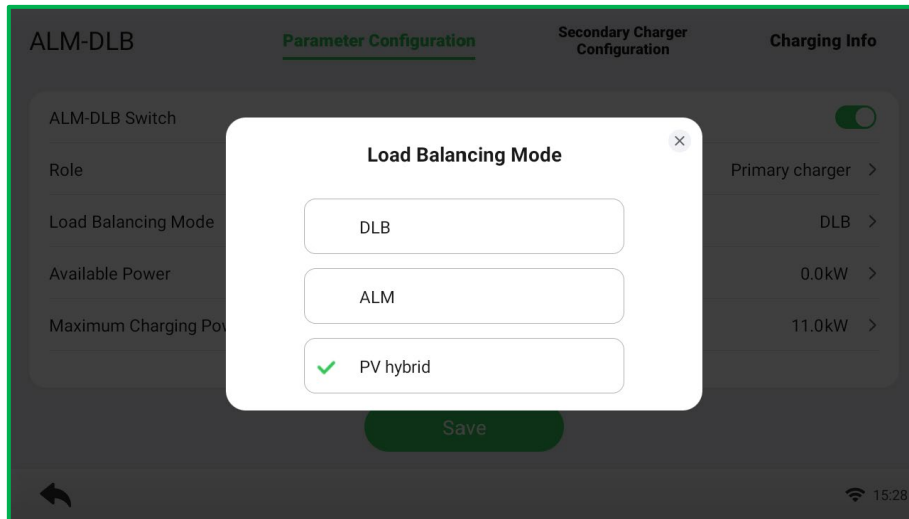

There are three charging modes available. The settings vary depending on the charging modes.

a) **Full Green Charging Mode**

- ✓ **Charging Mode:** Select **Full Green** from the charging mode options.
- ✓ **Meter Type:** Select the meter from the meter type options.
- ✓ **Maximum Charging Power of Charger:** lower than the rated power of the charger.
- ✓ **Charging Power for Offline Meter:** the default charging power for offline meter is 10% of the available power.

Tap **Save** once you have completed the settings.

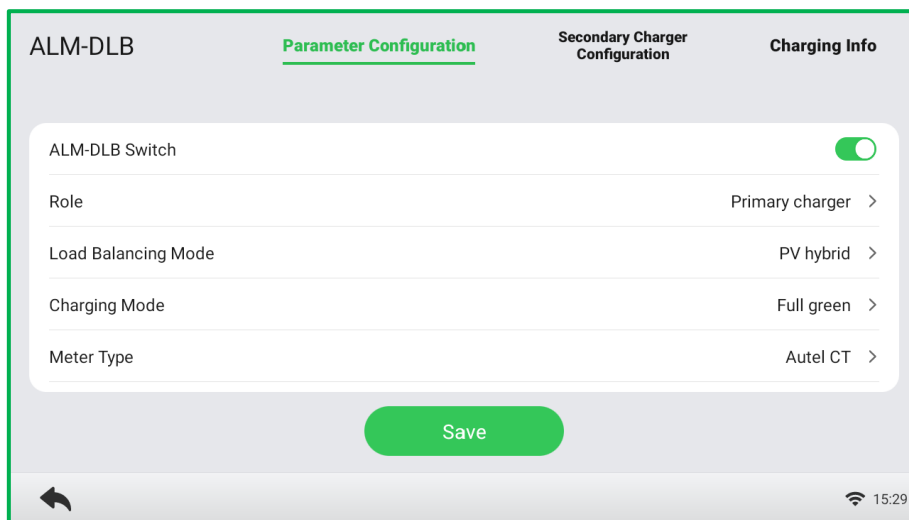

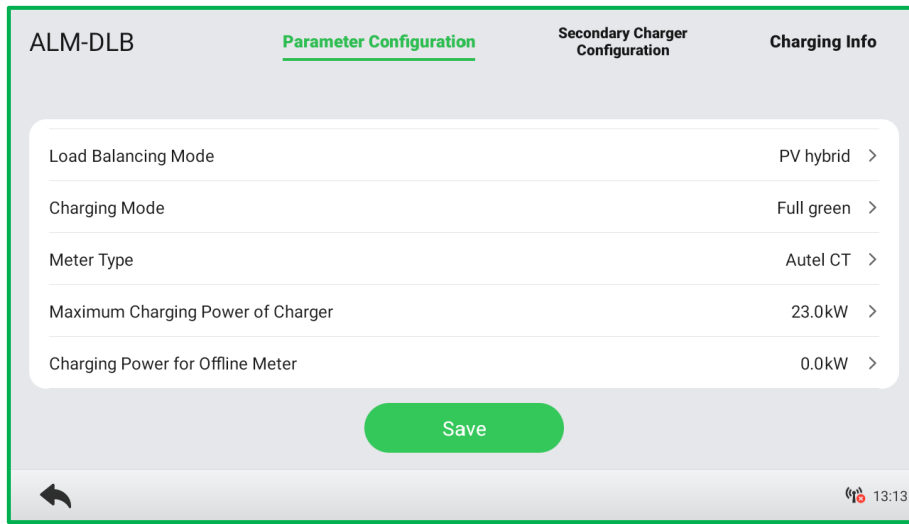

b) Green Priority Charging Mode

- ✓ **Charging Mode:** Select **Green Priority** from the charging mode options.
- ✓ **Available Power (kW):** you need to enter the available power that the system can supply to the chargers. You must enter a whole number.

The value of the available power should be within the following range:

- ◆ **Maximum Value:** lower than the upstream MCB/RCBO rated power.
- ◆ **Minimum Value:** higher than the minimum power of one charger (1.4 kW for single-phase, 4.2 kW for three-phase) x N (N represents the number of chargers in the device group).

- ✓ **Meter Type:** Select the meter from the meter type options.
- ✓ **Maximum Charging Power of Charger (kW):** lower than the rated power of the charger.
- ✓ **Minimum Charging Power (kW):** the sum of the minimum charging power of all chargers.
- ✓ **Charging Power for Offline Meter (kW):** the default charging power for offline meter is 10% of the available power.

Tap **Save** once you have completed the settings.

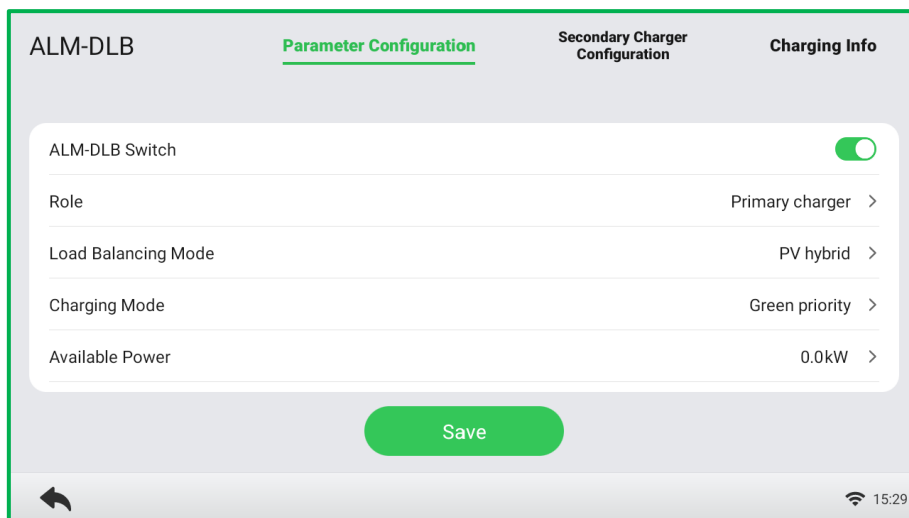

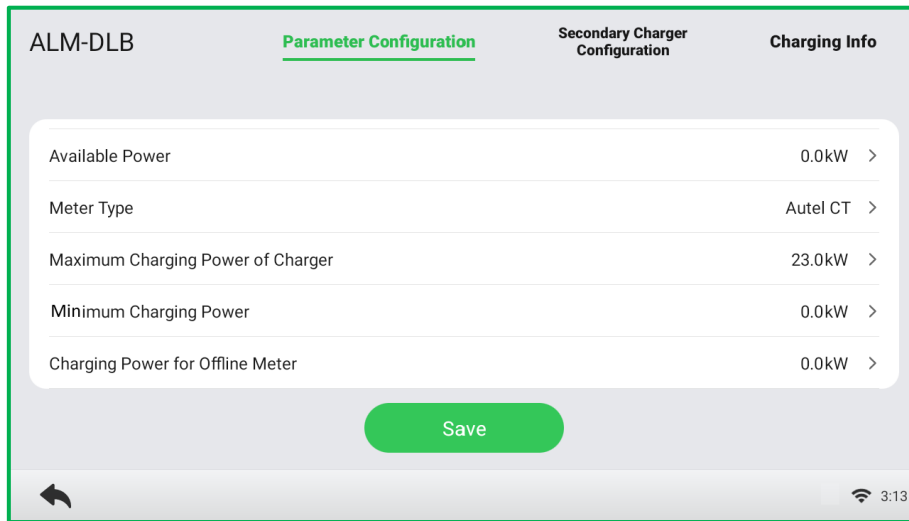

c) Speed Priority Charging Mode

- ✓ **Charging Mode:** Select **Speed Priority** from the charging mode options.
- ✓ **Available Power (kW):** you need to enter the available power that the system can supply to the chargers. You must enter a whole number.

The value of the available power should be within the following range:

- ◆ **Maximum Value:** lower than the upstream MCB/RCBO rated power.
- ◆ **Minimum Value:** higher than the minimum power of one charger (1.4 kW for single-phase, 4.2 kW for three-phase) x N (N represents the number of chargers in the device group).

- ✓ **Meter Type:** Select the meter from the meter type options.
- ✓ **Maximum Charging Power of Charger(kW):** lower than the rated power of the charger.
- ✓ **Charging Power for Offline Meter (kW):** the default charging power for offline meter is 10% of the available power.

Tap **Save** once you have completed the settings.

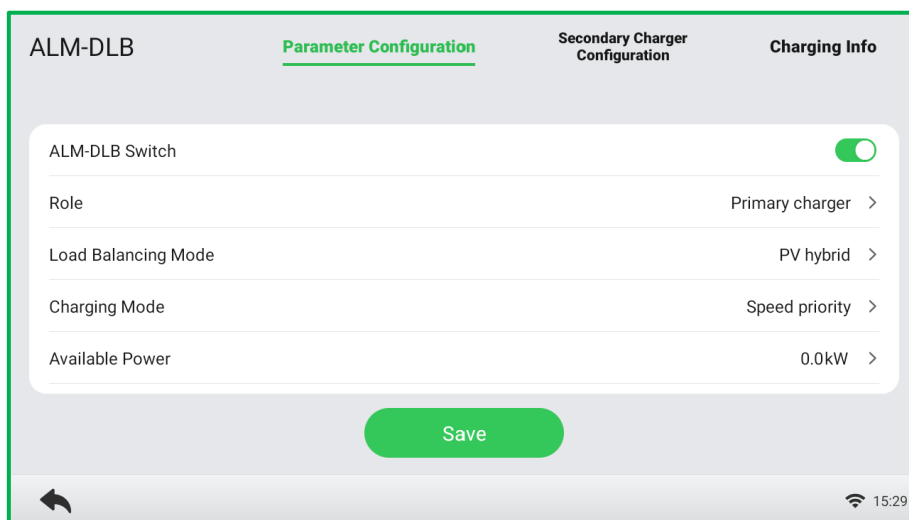

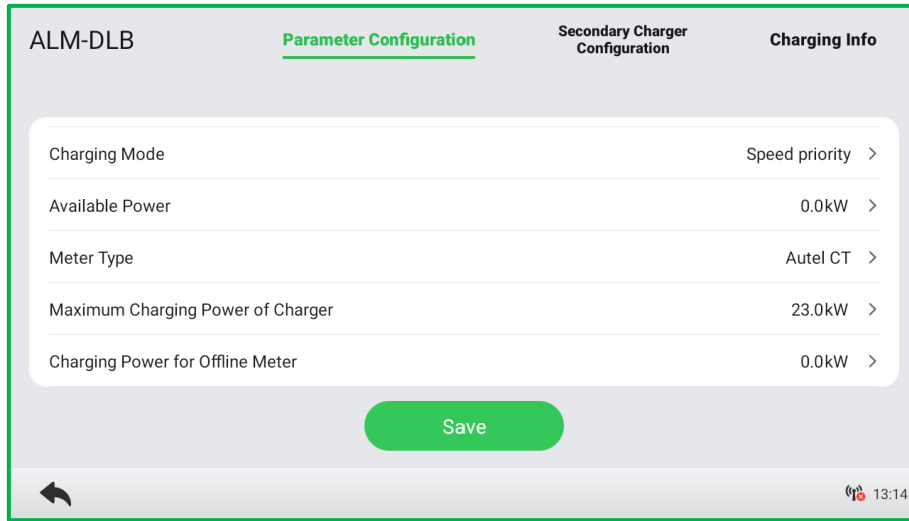

4. **Add secondary charger.** Tap on **Secondary Charger Configuration** and click on **Add Secondary Charger**. Add the secondary charger by inputting the recorded IP address and click on the **Save** button to save the setup.

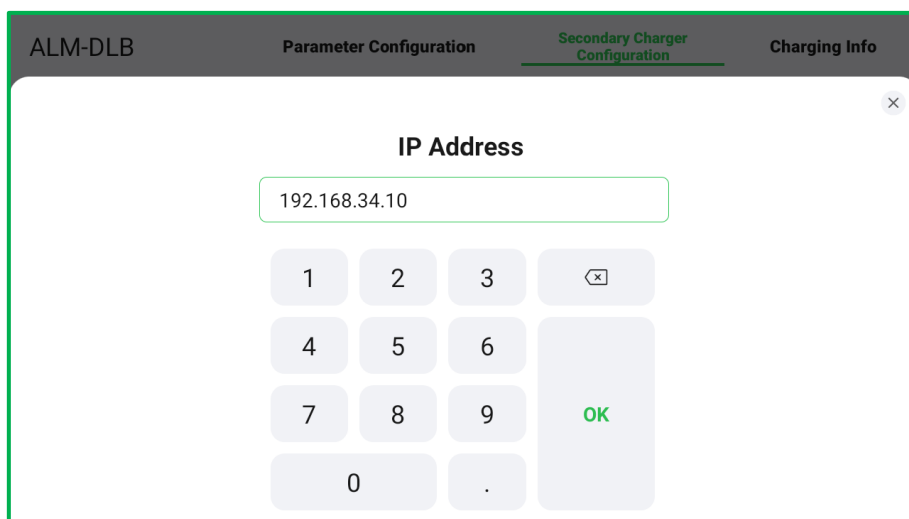
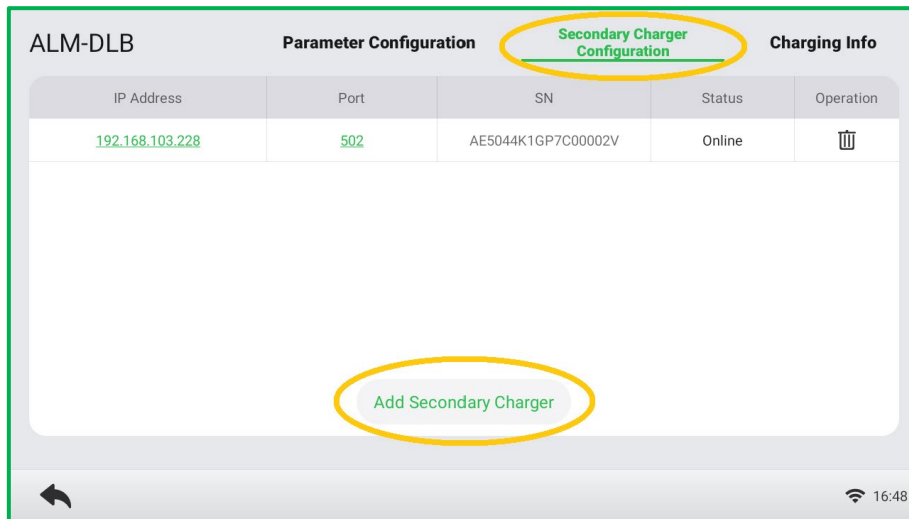

5. **Confirm configuration.** After all the setups above are completed, tap on **Charging Information** to confirm the configuration of the selected operating mode.

The screenshot displays the 'Parameter Configuration' screen for 'ALM-DLB'. At the top right, there are three tabs: 'Parameter Configuration', 'Secondary Charger Configuration', and 'Charging Info'. The 'Charging Info' tab is selected and highlighted with a yellow circle. Below the tabs, the text reads 'Total charging power:0 kW Real-time power displayed on meter:0 kW'. A table lists the charger configurations:

Role	SN	Status	Maximum Charging Power of Charger	Connector Status
Secondary charger	AE5044K1GP7C00002V	Online	40.0 kW	A: Available B: Available
Primary charger	AE5044K1GP7C000061	Online	22.0 kW	A: Available B: Available

At the bottom left, there is a back arrow icon. At the bottom right, there is a Wi-Fi icon and the time '16:49'.

4.3 Configuration via the Autel ChargeAPP

Follow the steps below to activate the operating modes via the Autel ChargeAPP once you have installed and wired all the units according to the system diagram.

4.3.1 For Scenarios with Single Charger

4.3.1.1 Set up DLB Mode (Power Sharing)

1. **Log in** to your Autel ChargeAPP using your account and password, then add chargers. For detailed instructions, please refer to *MaxiCharger Single Charger_Commissioning Guide_CE*.

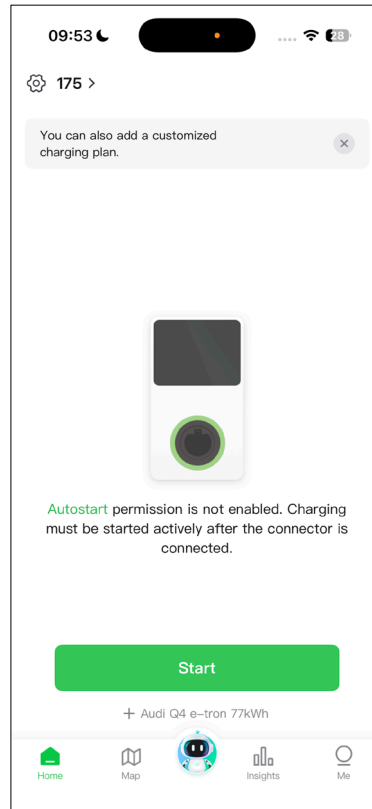

2. **Enter the Load Balancing page.** After successfully logging in, tap the  icon on the upper-left corner of the **Home** page. Tap **Load Balancing** to access the load balancing function.

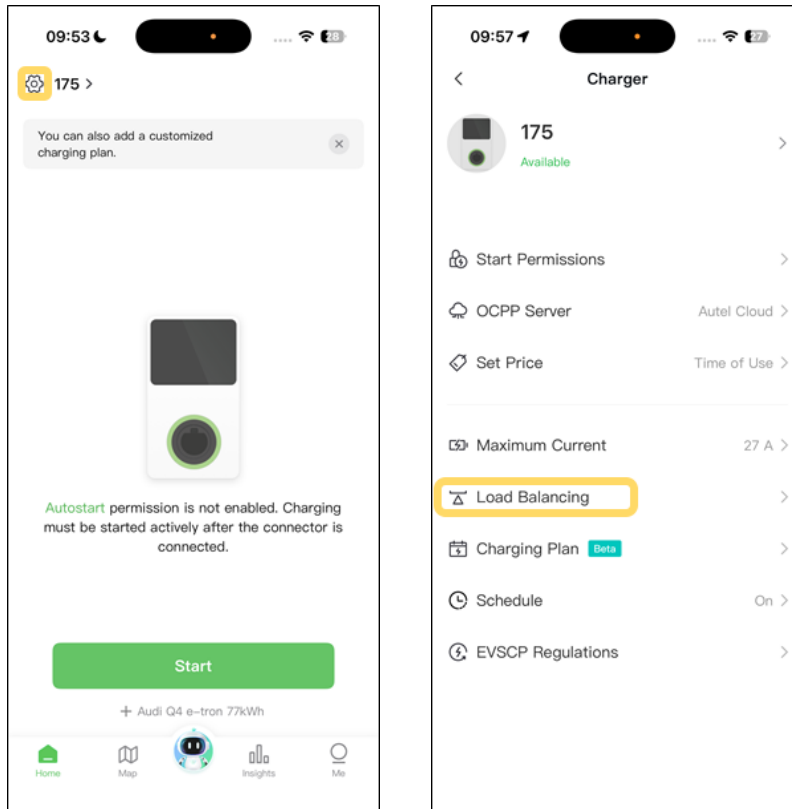

3. **Select Power Sharing mode.** After accessing the load balancing function, tap **Power Sharing**. A brief description about this mode will display on the page. Tap **Set as Primary** to designate the charger as the primary charger.

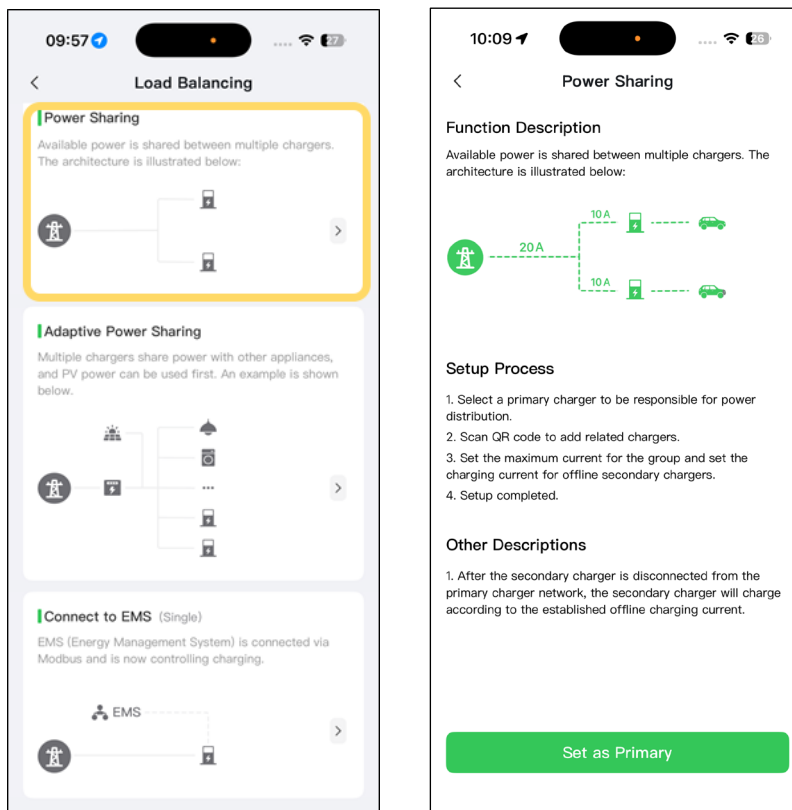

4. **Set Power Sharing mode.** After designating the primary charger, you must configure it for DLB mode.

- ✓ **Maximum Allocable Current:** configure based on the actual conditions.
- ✓ **Charging Current for Offline Secondary Chargers:** configure based on the actual conditions.
- ✓ **Types of AC Power Distribution:** select based on the actual type of AC power distribution for the site.
- ✓ **Secondary:** tap **Scan to add** or choose chargers from the charger list to add other chargers connected to the same network.

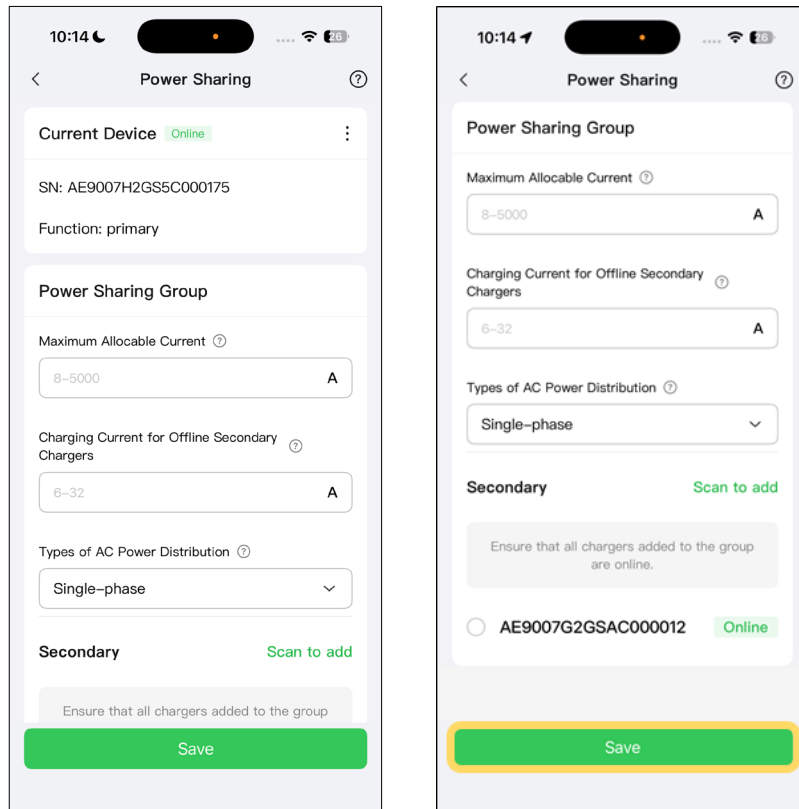

After all the settings above are completed, tap **Save** once you have confirmed.

5. **Finish configuration.** Real-time charging details will be displayed on the current page. If you tap “<” icon on the upper-left corner of the charging details page, you will return to the mode selection page. The **Power Sharing** box will be placed at the top of the mode selection page, and the **Enabled** tag will appear on this mode, indicating that DLB mode is activated and your chargers can be charged according to your settings.

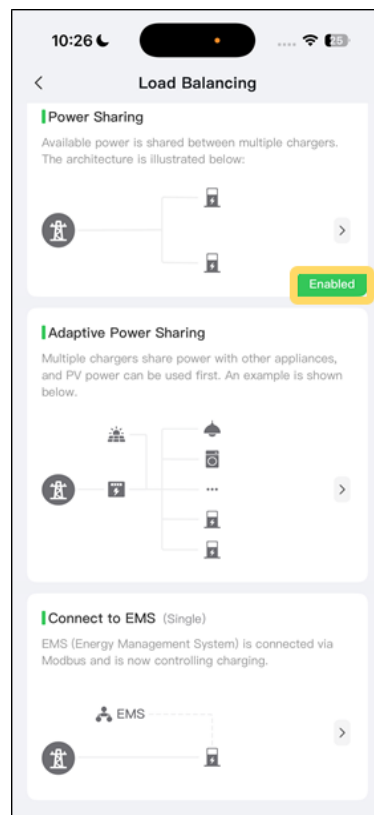
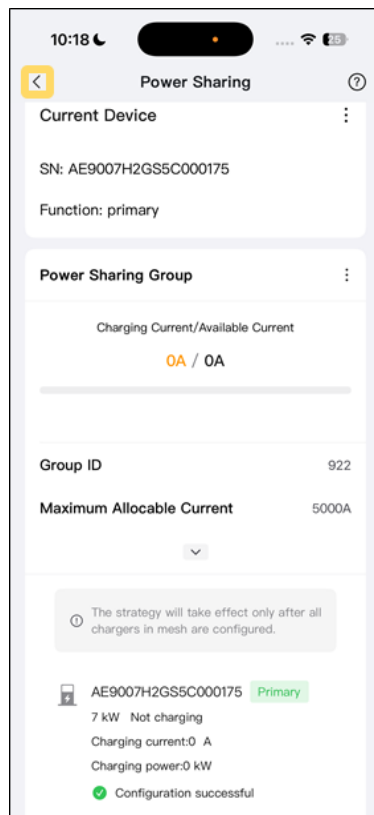

4.3.1.2 Set up ALM Mode (Adaptive Power Sharing)

1. **Log in** to your Autel ChargeAPP using your account and password, then add chargers. For detailed instructions, please refer to *MaxiCharger Single Charger_Commissioning Guide_CE*.

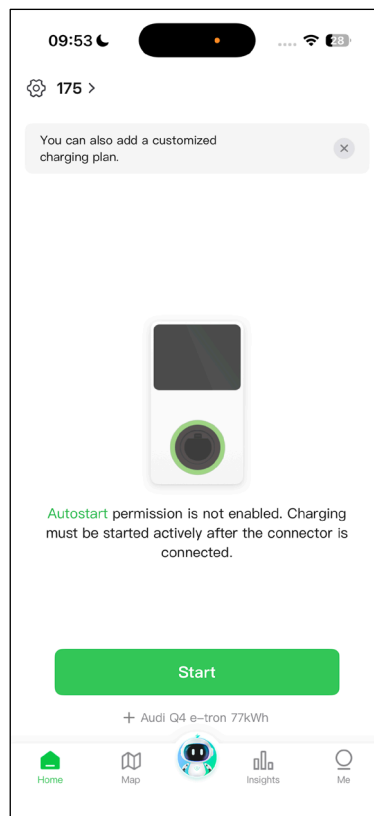

2. **Enter the Load Balancing page.** After successfully logging in, tap the  icon on the upper-left corner of the **Home** page. Tap **Load Balancing** to access the load balancing function.

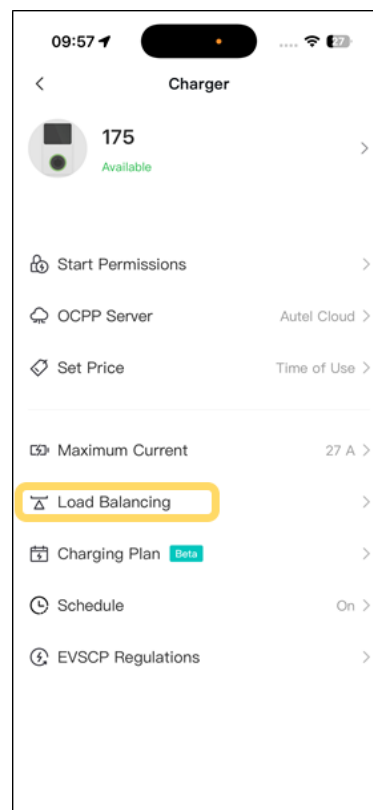
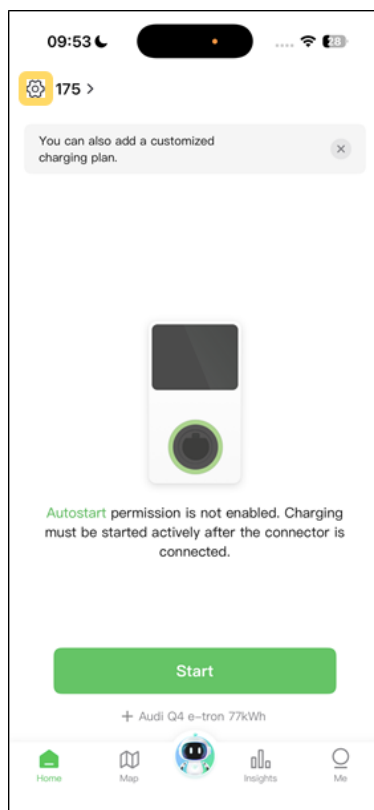

3. **Select Adaptive Power Sharing mode.** After accessing the load balancing function, tap **Adaptive Power Sharing**. A brief description about this mode will display on the page. Tap **Set as Primary** to designate the charger as the primary charger.

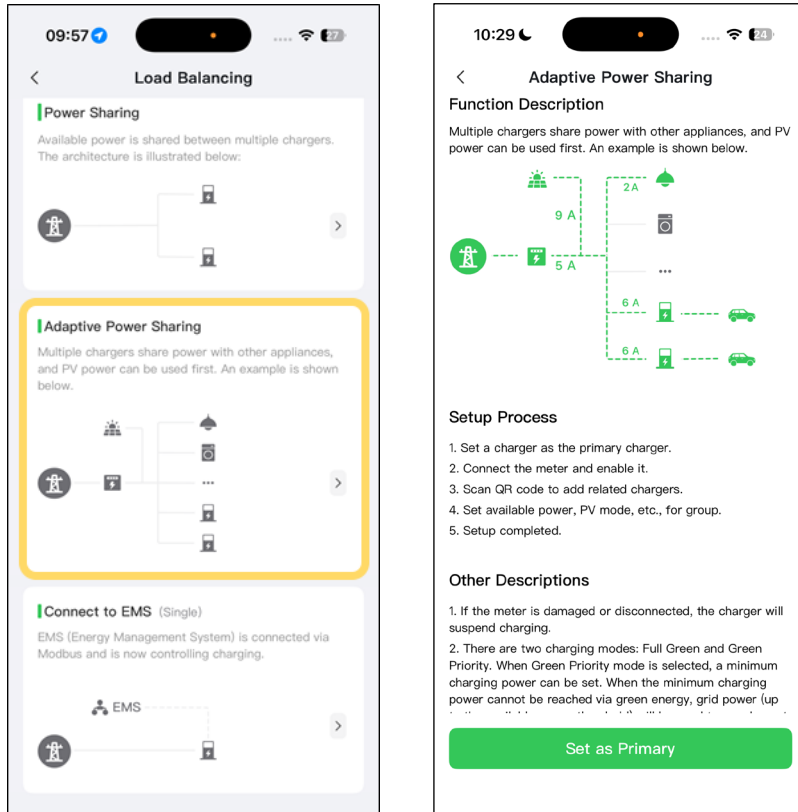

4. **Set up Adaptive Power Sharing mode.** After designating the primary charger, you must configure it for ALM mode.

- ✓ **Types of AC Power Distribution:** select based on the actual type of AC power distribution for the site.
- ✓ **Meter Type:** select the type of device used by the primary device to collect the real-time current of the main circuit.
- ✓ **Meter S/N:** configure based on the actual conditions.
- ✓ **Maximum Main Circuit Current:** configure based on the actual conditions.
- ✓ **Maximum Allocable Current:** configure based on the actual conditions.
- ✓ **Charging Current for Offline Secondary Chargers:** configure based on the actual conditions.
- ✓ **PV Mode:** select based on the actual conditions.

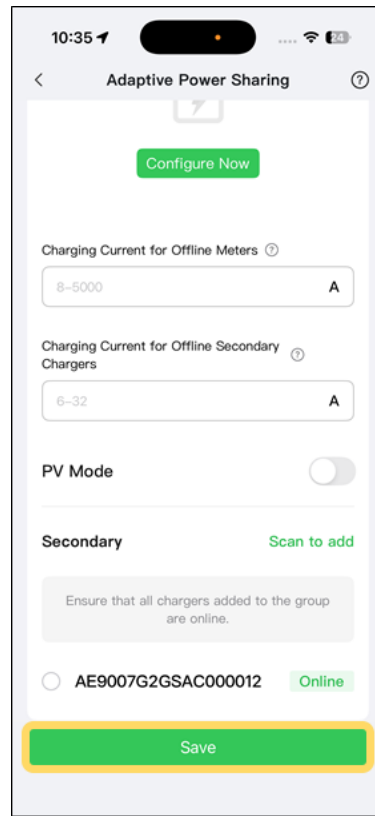
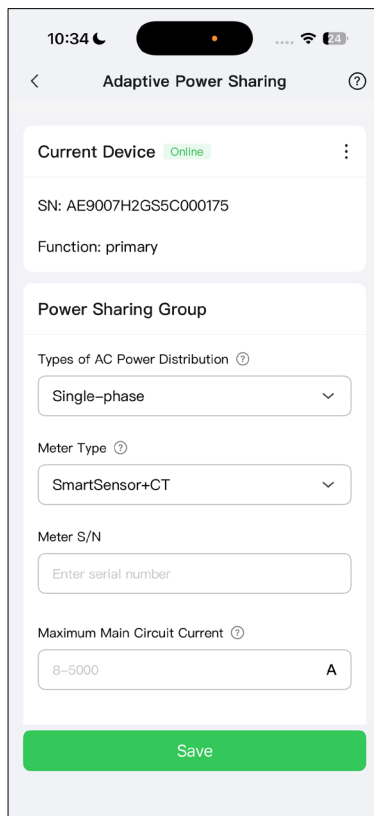

After all the settings above are completed, tap **Save** once you have confirmed.

- 5. Finish configuration.** Real-time charging details will be displayed on the current page. If you tap “<” icon on the upper-left corner of the charging details page, you will return to the mode selection page. The **Adaptive Power Sharing** box will be placed at the top of the mode selection page, and the **Enabled** tag will appear on this mode, indicating that ALM mode is activated and your chargers can be charged according to your settings.

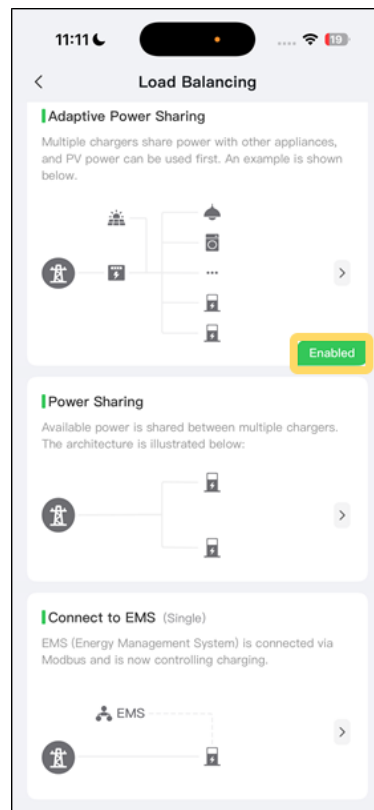
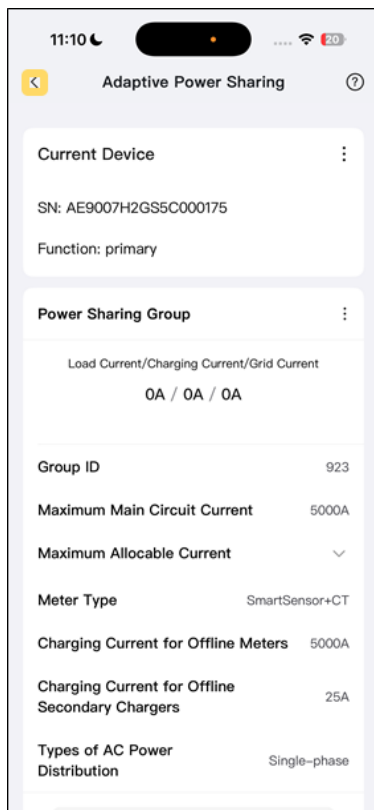

4.3.1.3 Set up EMS Mode (Connect to EMS)

1. **Log in** to your Autel ChargeAPP using your account and password, then add chargers. For detailed instructions, please refer to *MaxiCharger Single Charger_Commissioning Guide_CE*.

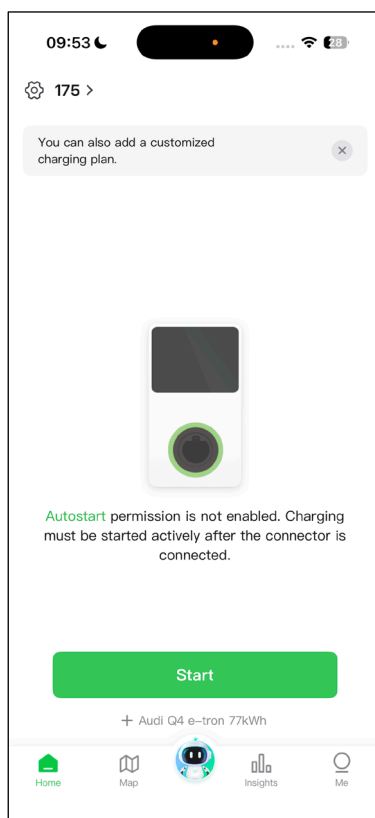

2. **Enter the Load Balancing page.** After successfully logging in, tap the  icon on the upper-left corner of the **Home** page. Tap **Load Balancing** to access the load balancing function.

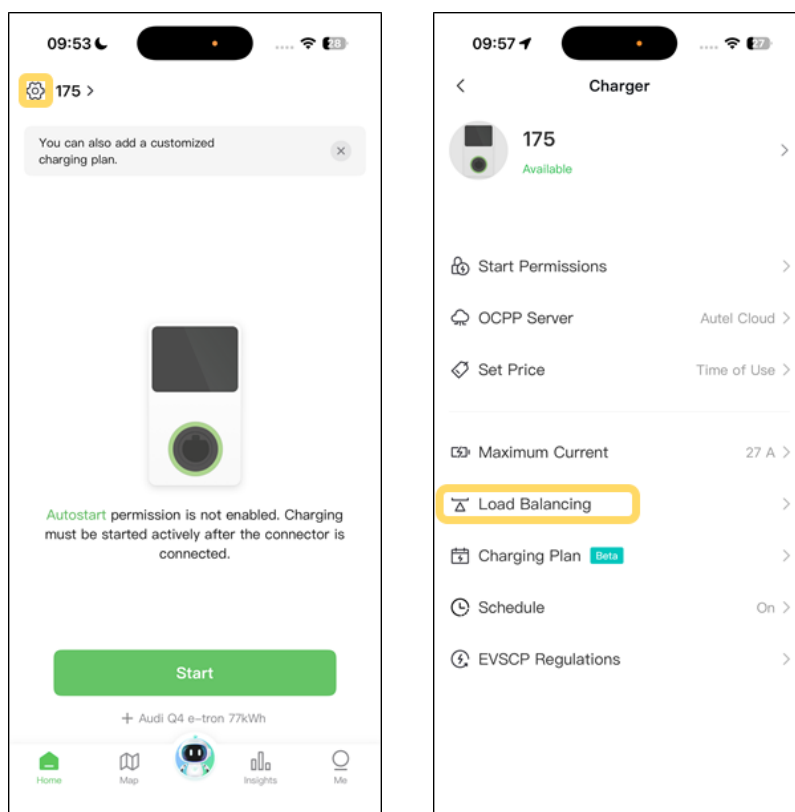

3. **Set up EMS mode.** After accessing the load balancing function, tap **Connect to EMS**. A brief description about this mode will display on the page. Tap **Start Setting** to configure EMS mode.

- ✓ **Connection Mode:** select **Charger as server** or **Charger as client** based on the actual conditions.
 - ◆ When **Charger as server** is selected, it means the charger acts as the server, and the Energy Management System actively connects to the charger based on the charger's IP address and port.
 - ◆ When **Charger as client** is selected, it means the Energy Management System acts as the server, and the charger actively connects to the EMS based on its IP address and port.
- ✓ **Server IP Address:** manually or automatically configure the server IP address.
- ✓ **Server Port:** configure based on the actual conditions.

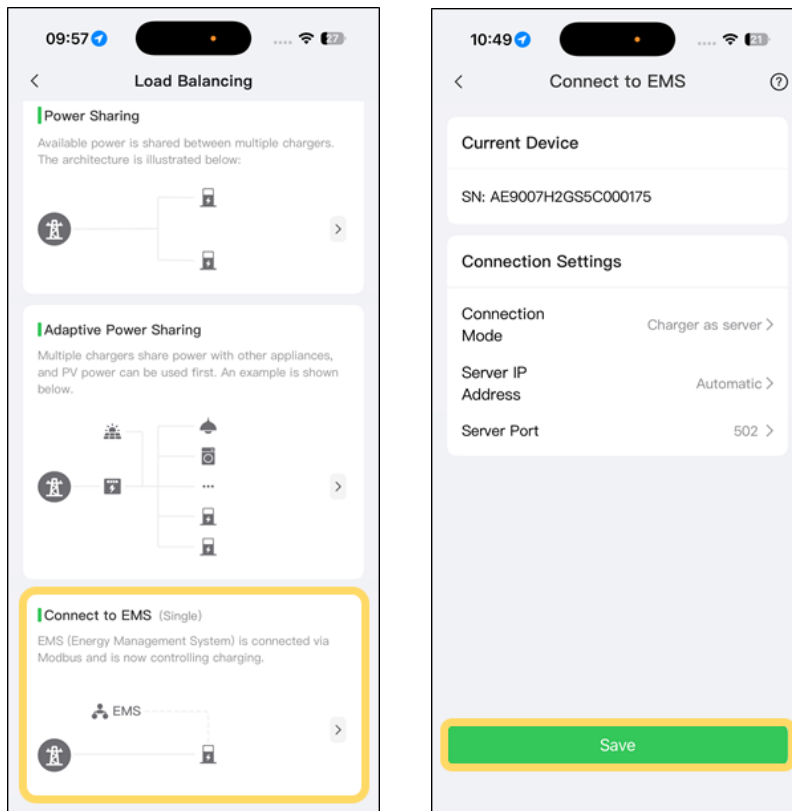

After all the settings above are completed, tap **Save** once you have confirmed.

4. **Finish configuration.** The connecting settings will be displayed on the current page. If you tap “<” icon on the upper-left corner of the charging details page, you will return to the mode selection page. The **Connect to EMS** box will be placed at the top of the mode selection page, and the **Enabled** tag will appear on this mode, indicating that EMS mode is activated and your chargers can be charged according to your settings.

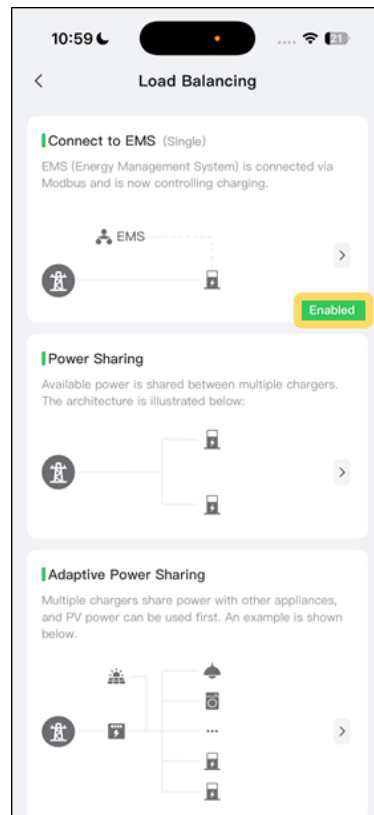
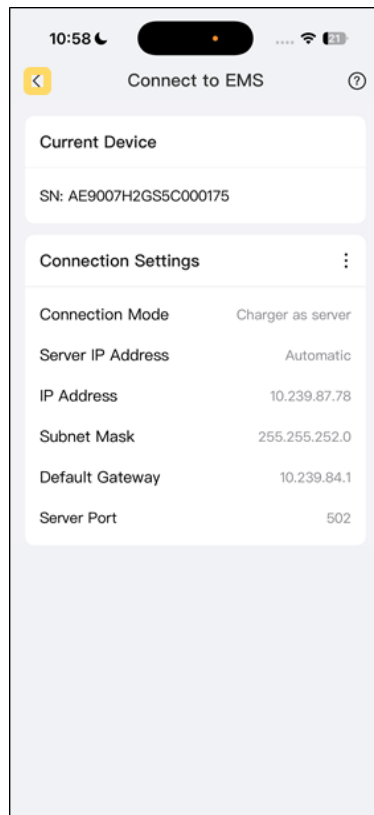

4.3.2 For Scenario with AC Wallbox/AC Compact

4.3.2.1 Set up DLB Mode

1. Refer to 3.3.3 to log in to Autel ChargeAPP and add a charger.
2. Add secondary chargers. Tap **Add** on the upper-right corner on the following screen and follow **STEP 3–4** in 3.3.3 to add more chargers and configure their Wi-Fi.

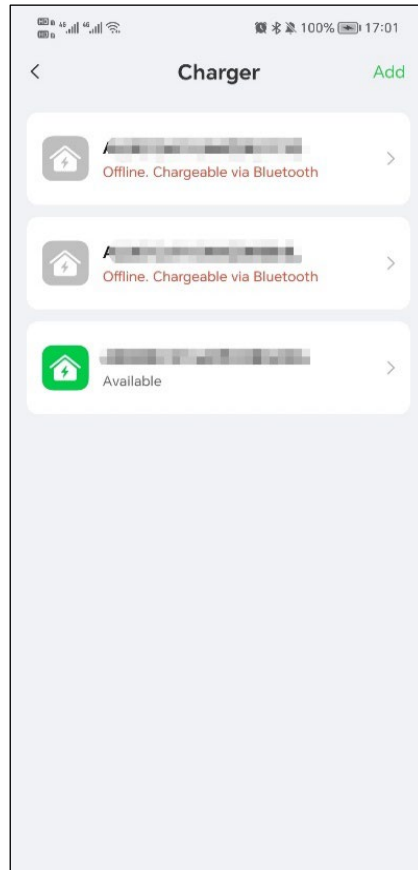

NOTE

Bluetooth can only be connected to one charger at a time. Switching the operation to another charger will disconnect the Bluetooth connection with the existing charger and connect it to a new charger.

All chargers added must be on the same Wi-Fi network.

After adding chargers and configuring them to the same Wi-Fi network, you can check if the chargers are configured for local DLB by viewing the Internet Connection Indicator.

➤ Internet Connection Indicator of AC Wallbox

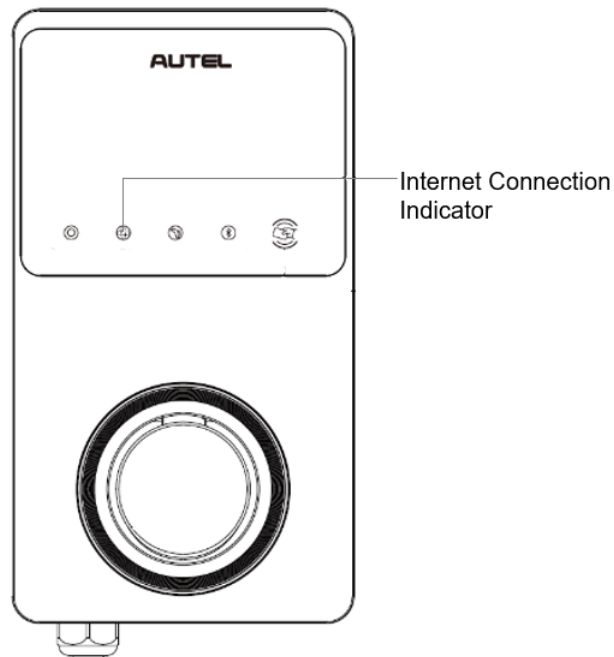

➤ Internet Connection Indicator of AC Compact

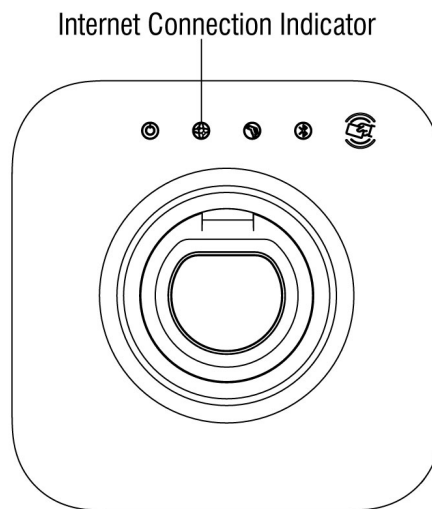

Internet Connection Indicator (AC Wallbox/AC Compact)

Indicator	Status	Description
Internet Connection Indicator	Steady On	Internet connected; Local DLB not enabled or EMS available.
	Steady Off	Internet not connected.
	Blink Fast	Internet not connected; Local DLB enabled.
	Blink Slow	Internet connected; Local DLB available.

3. **Set primary charger.** Tap **Account** > **Charger**. Select the charger connected to Bluetooth from the chargers list, then tap **Load Balancing** > **Power Sharing**. A brief description about this mode will display on the screen. Tap **Set as Primary** to designate the charger as the primary charger.

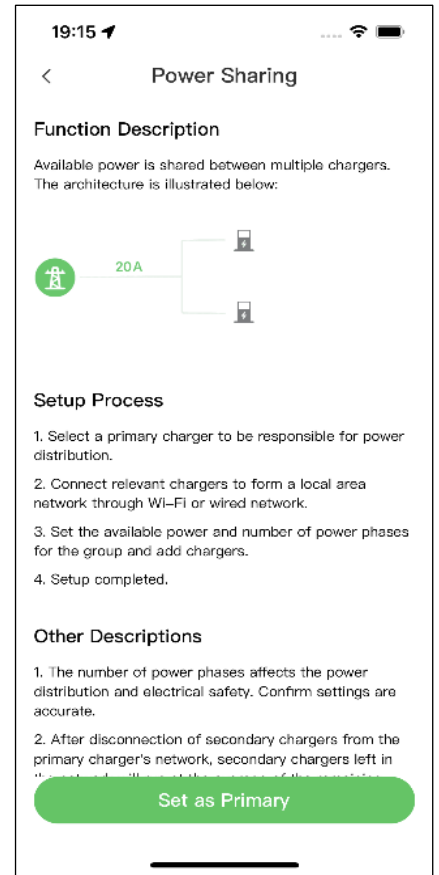
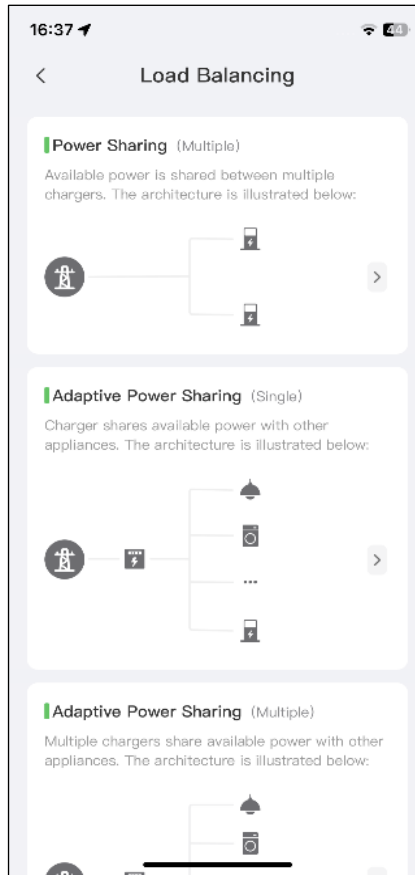
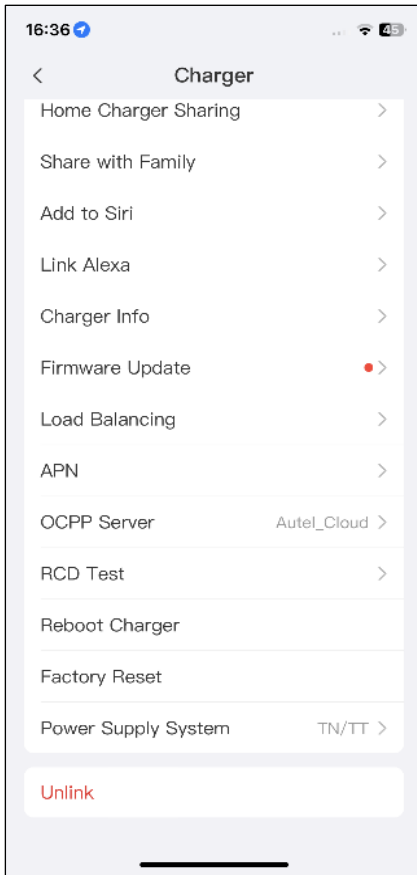

4. **Set up DLB mode.** After designating the primary charger, you must configure it for DLB mode.

- ✓ **Available Power (kW):** you must enter the available power that the system can supply to the chargers. This value must be expressed as a whole number.

The value of the available power should be within the following range:

- ◆ **Maximum Value:** lower than the upstream MCB/RCBO rated power.
 - ◆ **Minimum Value:** higher than the minimum power of one charger (1.4 kW for single-phase, 4.2 kW for three-phase) x N (N represents the number of chargers in the device group).
- ✓ **Number of Phases:** select **Single-phase** or **Three-phase** based on your power supply mode.
 - ✓ **Add secondary chargers:** tap **Add** to display other chargers connected to the same network. Tap **OK** once you have confirmed.

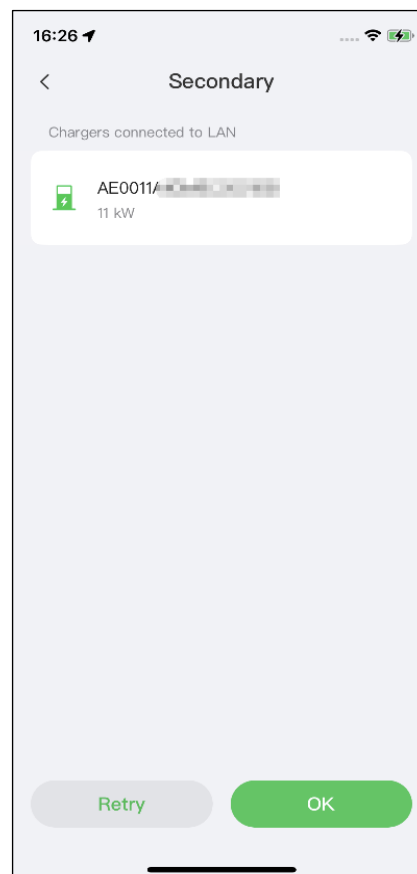
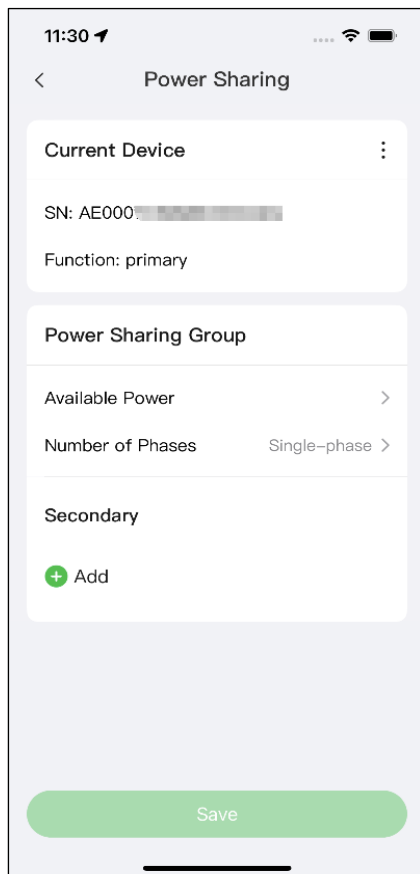

5. **Confirm configuration.** After all the settings above are completed, tap **Save** on the Power Sharing screen. The real-time charging details will display on the screen. Tap the “<” icon on the upper-left corner of the charging details screen to return to the mode selection screen. The **Enabled** tag will appear on this mode, indicating that DLB mode is activated and your chargers can be charged according to your settings.

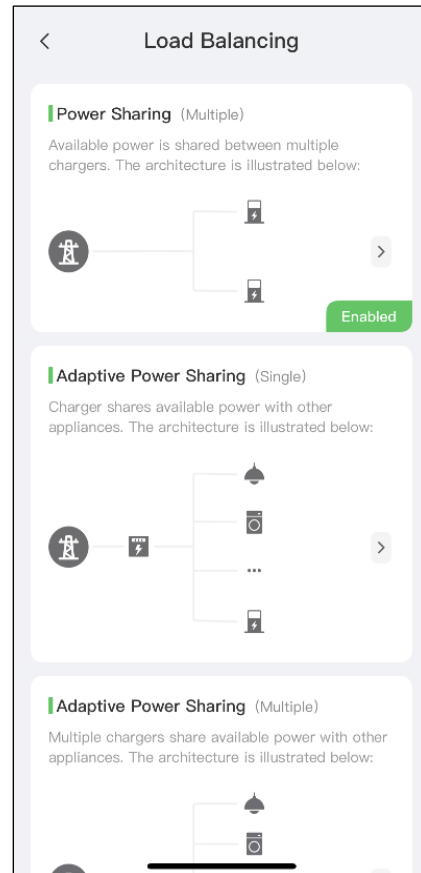
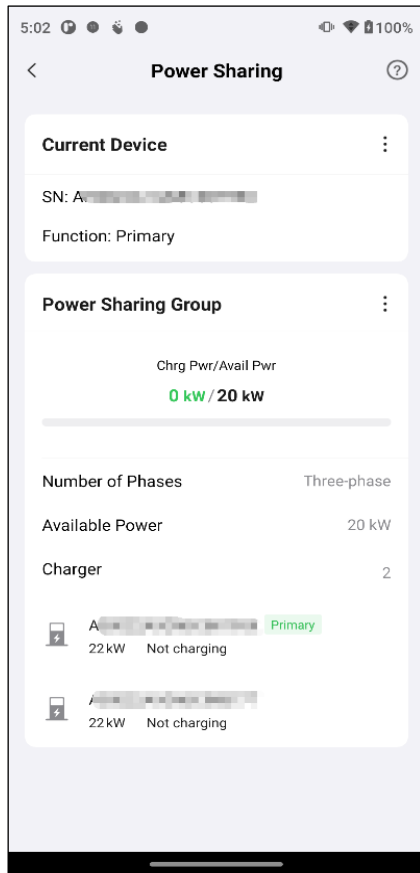

4.3.2.2 Set up ALM Mode w/Individual Charger

1. Refer to 3.3.3 to add chargers and configure Wi-Fi connection.
2. **Set primary charger.** Tap **Account** > **Charger**. Select the charger connected to Bluetooth from the chargers list, then tap **Load Balancing** > **Adaptive Power Sharing (Single)**. A brief description about this mode will display on the screen. Tap **Set as Primary** to designate the charger as the primary charger.

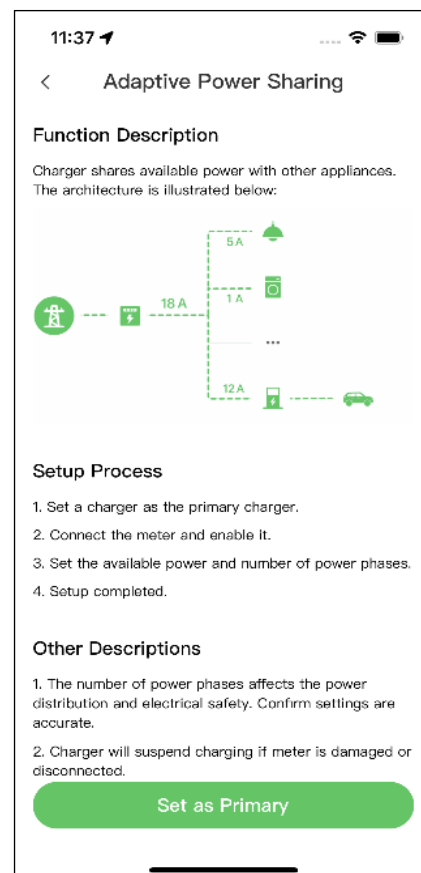
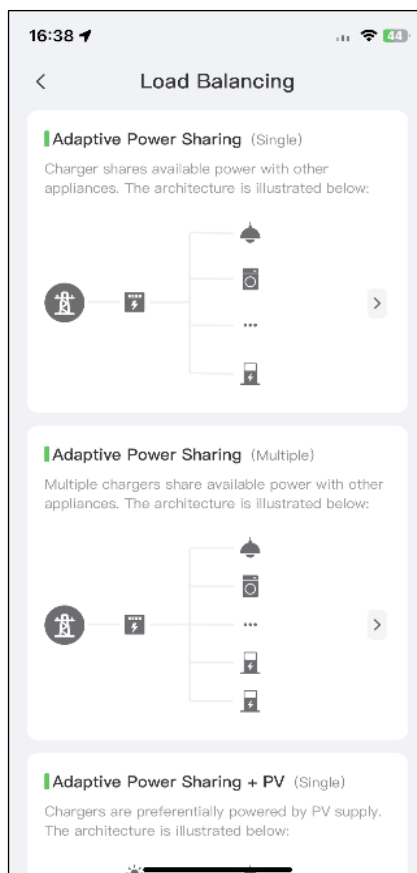
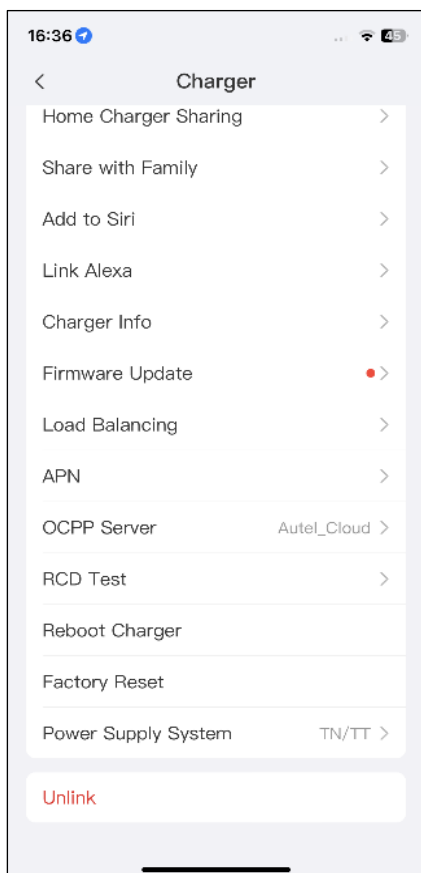

3. **Set up ALM mode w/individual charger.** After setting the primary charger, you need to complete the settings to set up ALM mode w/individual charger.

- ✓ **Smart Meter:** toggle the **Smart Meter** ON.
- ✓ **Available Power (kW):** you need to enter the available power that the system can supply to the chargers. You must enter a whole number.

The value of the available power should be within the following range:

- ◆ **Maximum Value:** lower than the upstream MCB/RCBO rated power.
 - ◆ **Minimum Value:** higher than the minimum power of one charger (1.4 kW for single-phase, 4.2 kW for three-phase) x N (N represents the number of chargers in the device group).
- ✓ **Power Reserve:** you must enter the power reserve for the charger, namely the reserved power not used for charging.
- ◆ The range of the power reserve is from 0–50%. The maximum reserved power that can be entered is 50% of the total home power.
 - ◆ The default setting of the power reserve is 10%, which is used for the dynamic power change caused by load switching in and out.
- ✓ **Number of Phases:** select **Single-phase** or **Three-phase** based on your power supply mode.

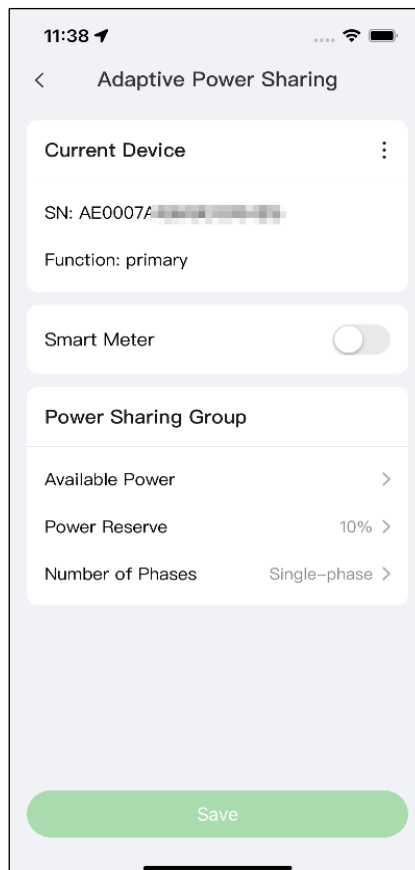

4. **Confirm configuration.** After all the settings above are completed, tap **Save** on the Adaptive Power Sharing screen. The real-time charging details will display on the screen. Tap the “<” icon on the upper-left corner of the charging details screen to return to the mode selection screen. The **Enabled** tag will appear on this mode, indicating that the ALM mode w/individual charger is activated and your charger can now be charged according to your settings.

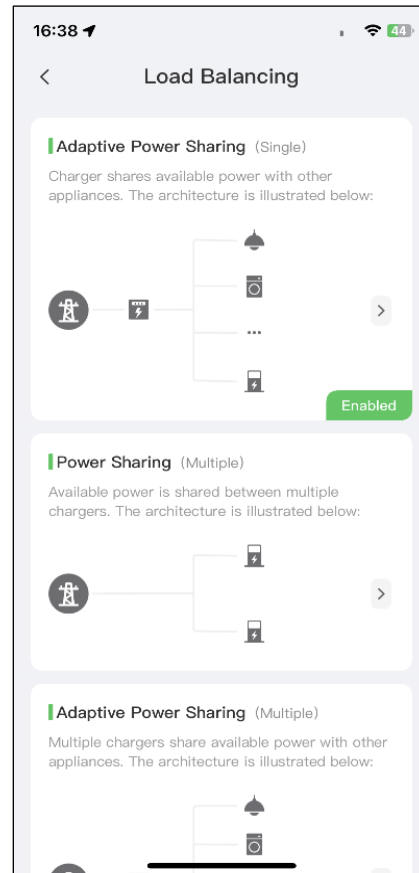
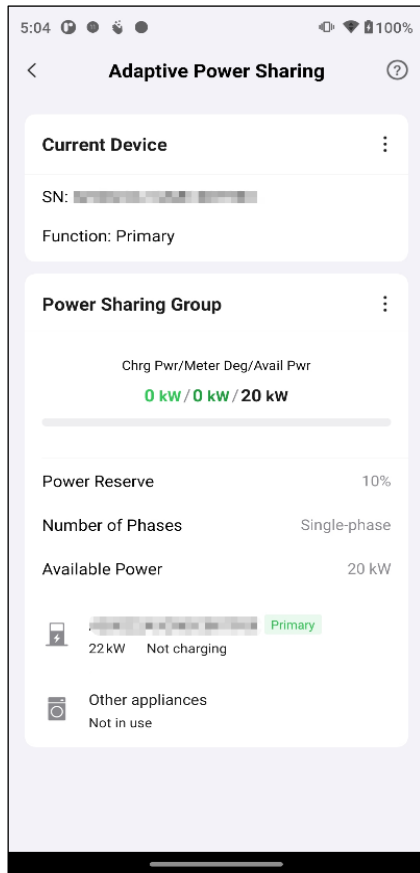

4.3.2.3 Set up ALM Mode w/Multiple Chargers

1. Refer to 3.3.3 to log in to Autel ChargeAPP and add a charger.
2. Add secondary chargers. Tap **Add** on the upper-right corner on the following screen and follow **STEP 3–4** in 3.3.3 to add more chargers and configure their Wi-Fi.

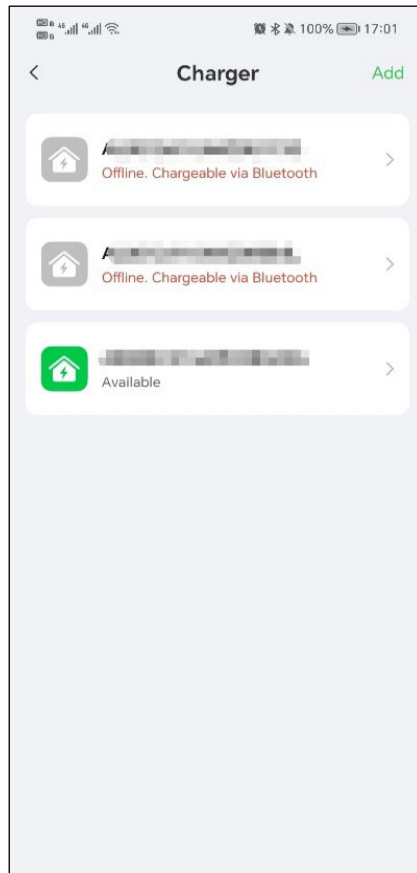

3. **Set primary charger.** Tap **Account** > **Charger**. Select the charger connected to Bluetooth from the chargers list, then tap **Load Balancing** > **Adaptive Power Sharing (Multiple)**. A brief description about this mode will display on the screen. Tap **Set as Primary** to set the charger as primary charger.

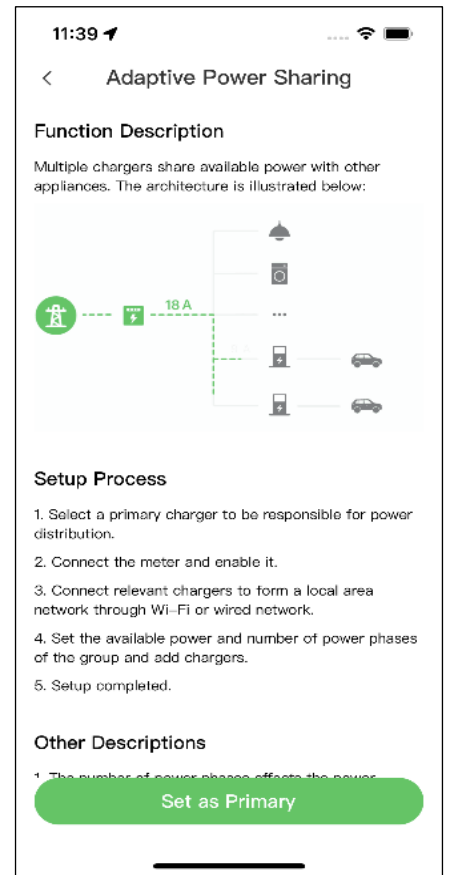
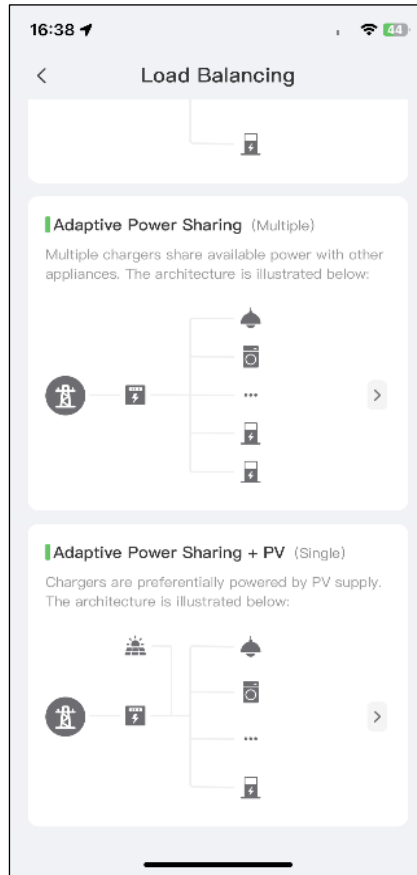
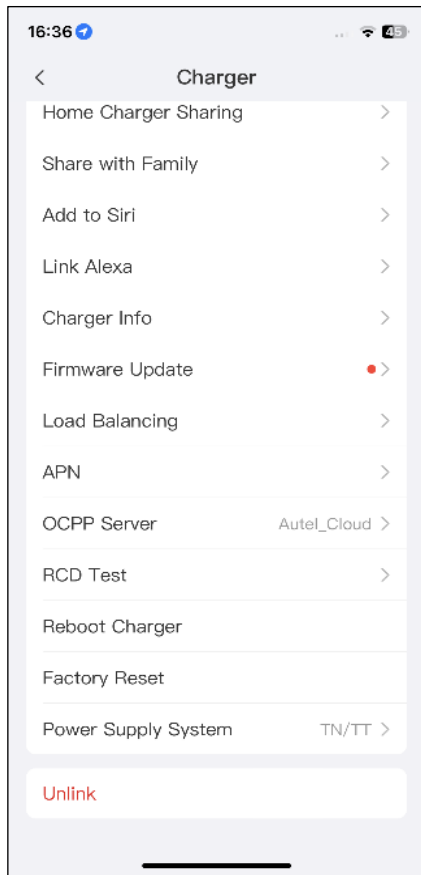

4. **Set up ALM mode w/multiple chargers.** After designating the primary charger, you need to complete the settings to set up ALM mode w/multiple chargers.

- ✓ **Smart Meter:** toggle the **Smart Meter** ON.
- ✓ **Available Power (kW):** you need to enter the available power the system can supply to the chargers. You must enter a whole number.

The value of the available power should be within the following range:

- ◆ **Maximum Value:** lower than the upstream MCB/RCBO rated power.
 - ◆ **Minimum Value:** higher than the minimum power of one charger (1.4 kW for single-phase, 4.2 kW for three-phase) x N (N represents the number of chargers in the device group).
- ✓ **Power Reserve:** you must enter the power reserve for the chargers, namely the reserved power not used for charging.
- ◆ The range of the power reserve is from 0–50%. The maximum reserved power that can be entered is 50% of the total home power.
 - ◆ The default setting of the power reserve is 10%, which is used for the dynamic power change caused by load switching in and out.
- ✓ **Number of Phases:** select **Single-phase** or **Three-phase** based on your power supply mode.
- ✓ **Add Secondary Chargers:** tap **Add** to display other chargers connected to the same network. Tap **OK** once you have confirmed.

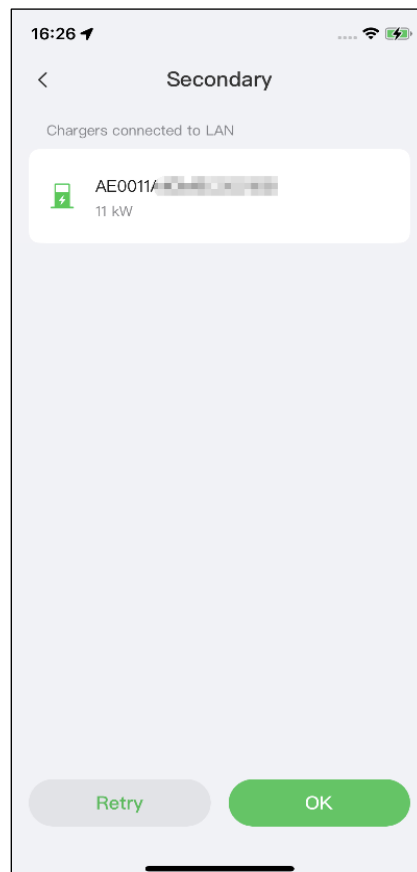
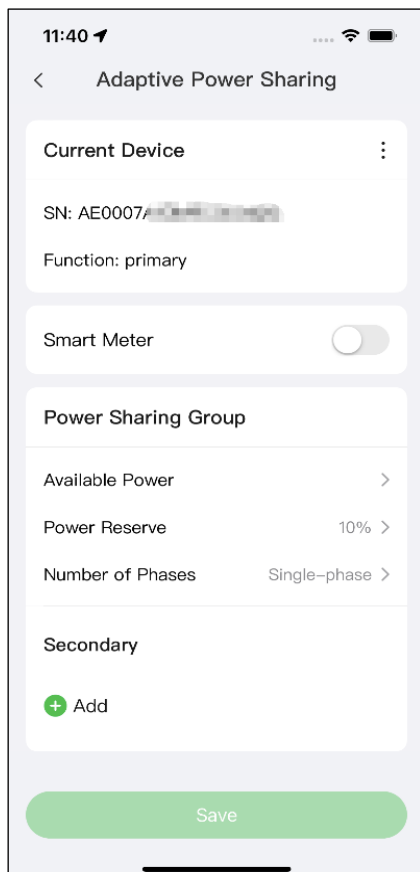

5. **Confirm configuration.** After all the settings above are completed, tap **Save** on the Adaptive Power Sharing screen. The real-time charging details will display on the screen. Tap the “<” icon on the upper-left corner of the charging details screen to return to the mode selection screen. The **Enabled** tag will appear on this mode, indicating that ALM mode w/multiple chargers is activated and your chargers can now be charged according to your settings.

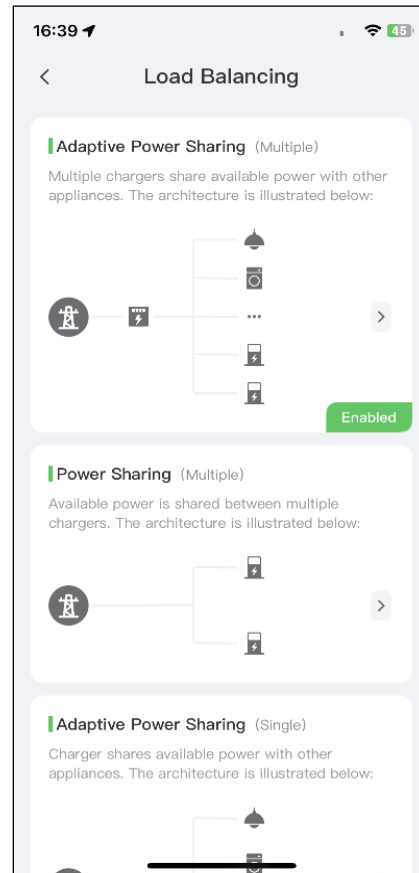
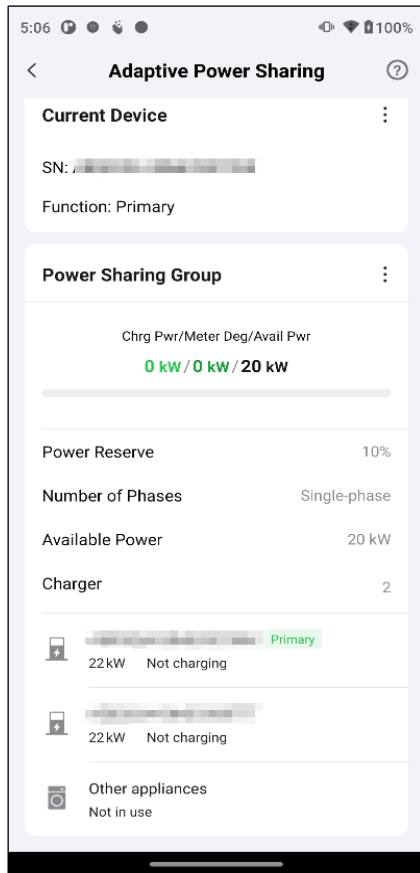

4.3.2.4 Set up PV Mode w/Individual Charger

1. Refer to 3.3.3 to add chargers and configure Wi-Fi connection.
2. **Set primary charger.** Tap **Account** > **Charger**. Select the charger connected to Bluetooth from the chargers list, then tap **Load Balancing** > **Adaptive Power Sharing + PV (Single)**. A brief description about this mode will appear on the screen. Tap **Set as Primary** to designate the charger as the primary charger.

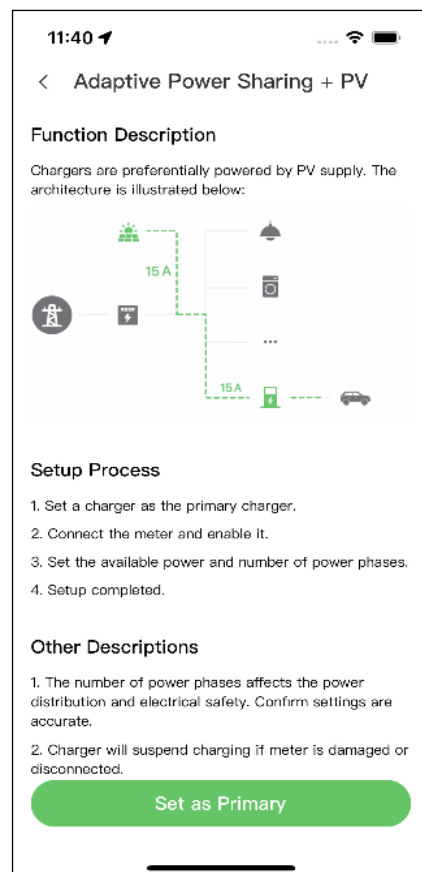
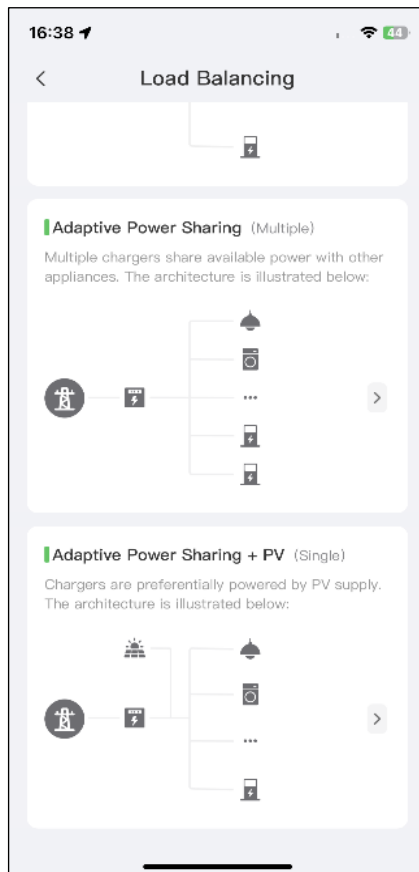
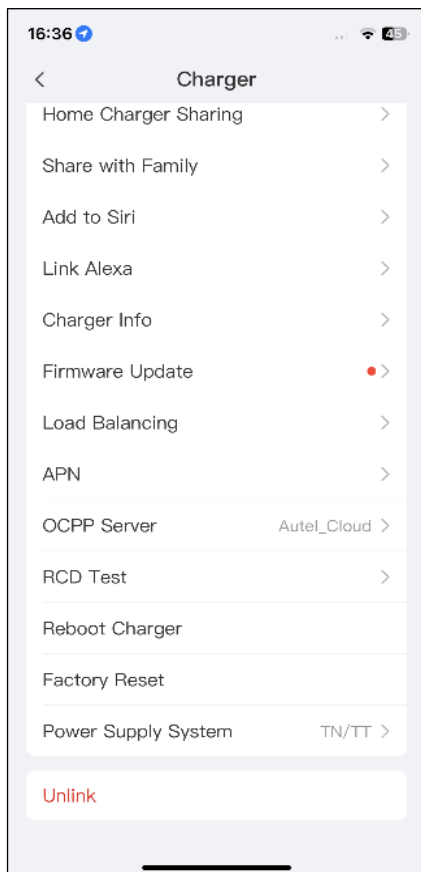

3. **Set up PV Hybrid mode w/individual charger.** After designating the primary charger, you need to complete the settings to configure PV Hybrid mode w/individual charger.

- ✓ **Smart Meter:** toggle the **Smart Meter** ON.
- ✓ **Available Power (kW):** you need to enter the available power that the system can supply to the chargers. You must enter a whole number.

The value of the available power should be within the following range:

- ◆ **Maximum Value:** lower than upstream MCB/RCBO rated power.
 - ◆ **Minimum Value:** higher than the minimum power of one charger (1.4 kW for single-phase, 4.2 kW for three-phase) x N (N represents the number of chargers in the device group).
- ✓ **Number of Phases:** select **Single-phase** or **Three-phase** based on your power supply mode.

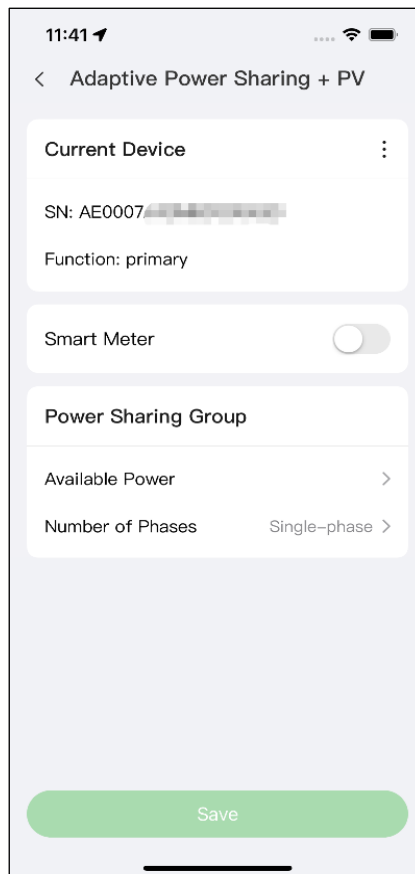

4. **Confirm configuration.** After all the settings above are completed, tap **Save** on the Adaptive Power Sharing + PV screen. The real-time charging details will display on the screen. Tap the “<” icon on the upper-left corner of the charging details screen to return to the mode selection screen. The **Enabled** tag will appear on this mode, indicating that PV Hybrid mode w/individual charger is activated. Your charger can now be charged according to your settings.

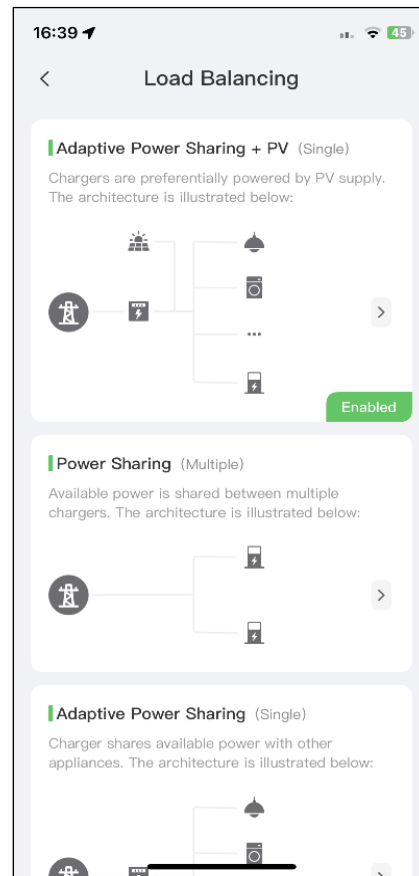
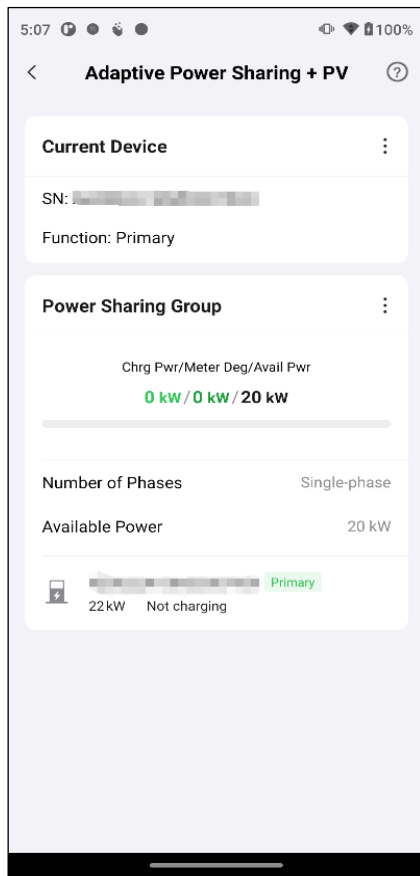

4.3.2.5 Set up PV Mode w/Multiple Chargers

1. Refer to [3.3.3](#) to log in to Autel ChargeAPP and add a charger.
2. Add secondary chargers. Tap **Add** on the upper-right corner on the following screen and follow **STEP 3–4** in [3.3.3](#) to add more chargers and configure their Wi-Fi.

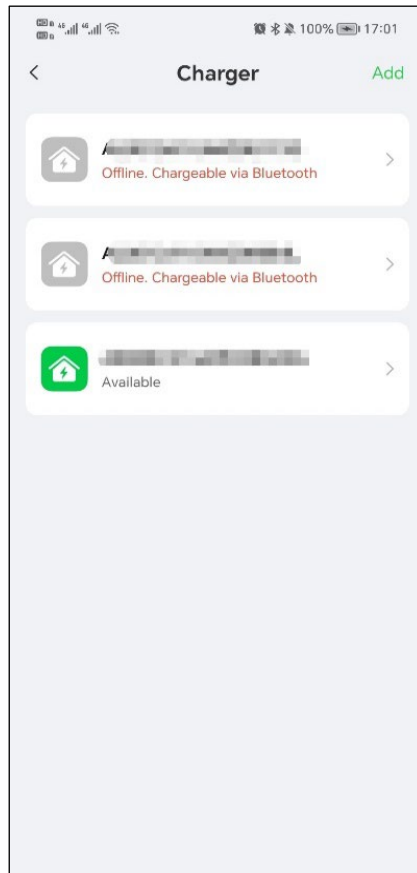

3. **Set primary charger.** Tap **Account** > **Charger**. Select the charger connected to Bluetooth from the chargers list, then tap **Load Balancing** > **Adaptive Power Sharing + PV (Multiple)**. A brief description about this mode will display on the screen. Tap **Set as Primary** to set the charger as primary charger.

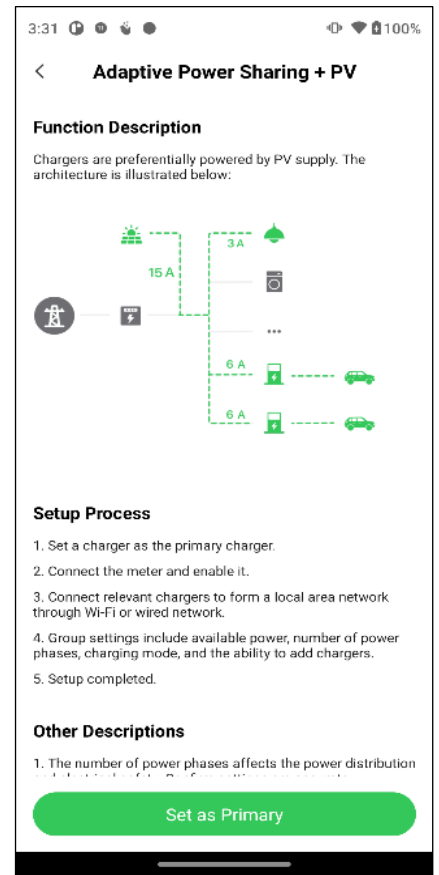
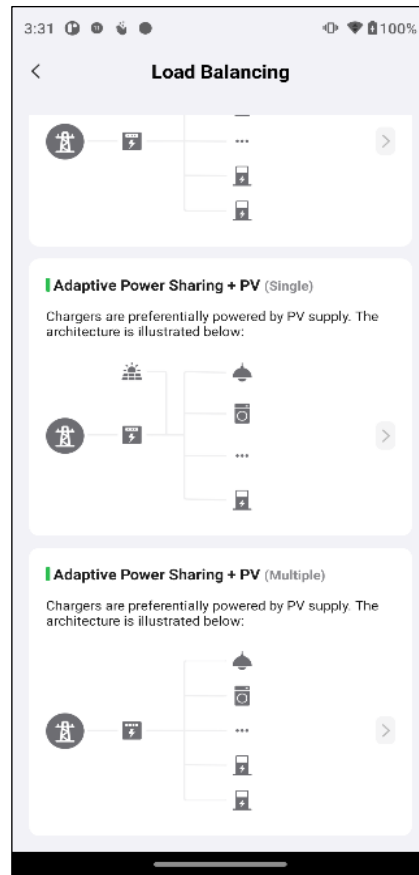
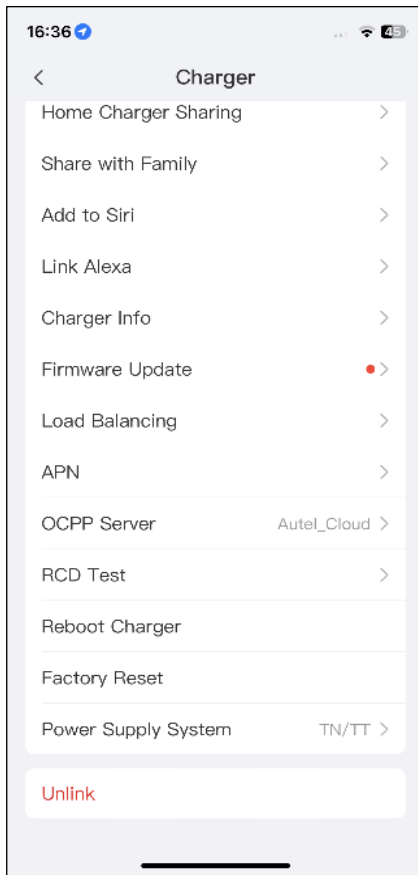

4. **Set up PV Hybrid mode w/multiple chargers.** After designating the primary charger, you need to complete the settings to configure PV Hybrid mode w/multiple chargers. There are three charging modes available. The settings vary depending on the charging modes.

a) **Full Green Charging Mode**

- ✓ **Smart Meter:** toggle the **Smart Meter** ON.
- ✓ **Number of Phases:** select **Single-phase** or **Three-phase** based on your power supply mode.
- ✓ **Charging Mode:** Select **Full Green** from the charging mode options.
- ✓ **Add Secondary Chargers:** tap **Add** to display other chargers connected to the same network. Tap **OK** once you have confirmed.

Tap **Save** once you have completed the settings. Then the real-time charging details will display on the screen.

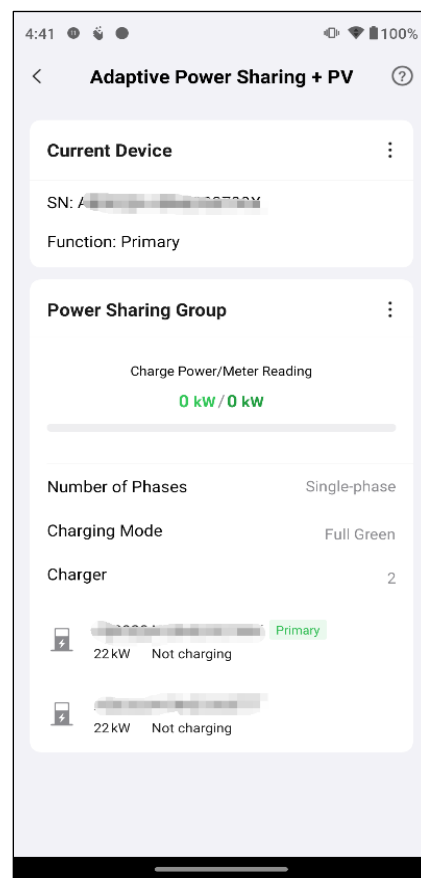
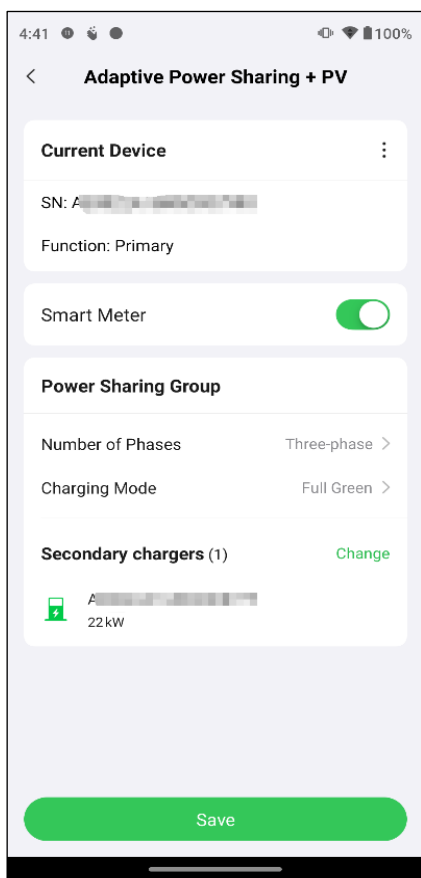

b) Green Priority Charging Mode

- ✓ **Smart Meter:** toggle the **Smart Meter** ON.
- ✓ **Number of Phases:** select **Single-phase** or **Three-phase** based on your power supply mode.
- ✓ **Charging Mode:** Select **Green Priority** from the charging mode options.
- ✓ **Available Power (kW):** you need to enter the available power that the system can supply to the chargers. You must enter a whole number.

The value of the available power should be within the following range:

- ◆ **Maximum Value:** lower than upstream MCB/RCBO rated power.
 - ◆ **Minimum Value:** higher than the minimum power of one charger (1.4 kW for single-phase, 4.2 kW for three-phase) x N (N represents the number of chargers in the device group).
- ✓ **Minimum Charging Power (kW):** the sum of the minimum charging power of all chargers.
 - ✓ **Add Secondary Chargers:** tap **Add** to display other chargers connected to the same network. Tap **OK** once you have confirmed.

Tap **Save** once you have completed the settings. Then the real-time charging details will display on the screen.

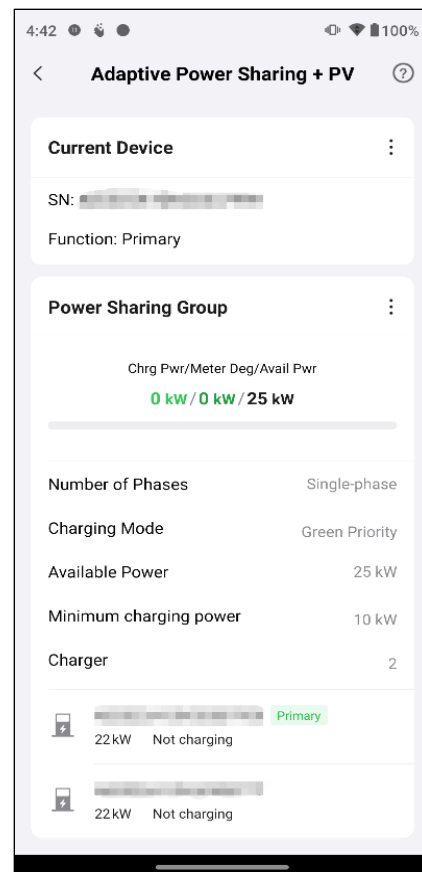
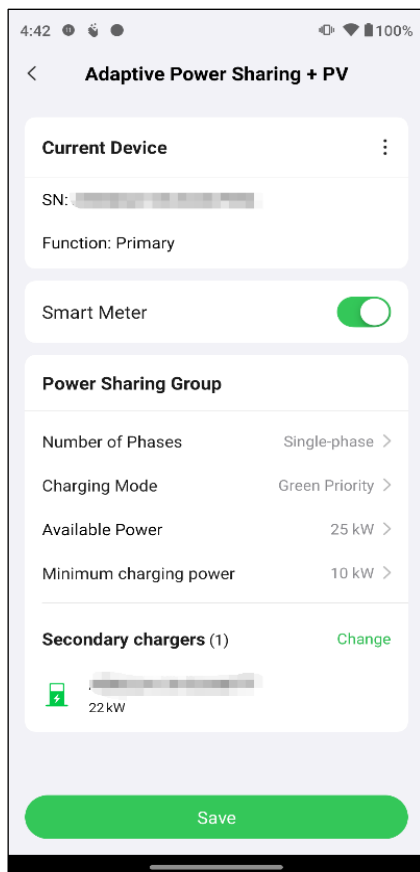

c) Speed Priority Charging Mode

- ✓ **Smart Meter:** toggle the **Smart Meter** ON.
- ✓ **Number of Phases:** select **Single-phase** or **Three-phase** based on your power supply mode.
- ✓ **Charging Mode:** Select **Speed Priority** from the charging mode options.
- ✓ **Available Power (kW):** you need to enter the available power that the system can supply to the chargers. You must enter a whole number.

The value of the available power should be within the following range:

- ◆ **Maximum Value:** lower than upstream MCB/RCBO rated power.
 - ◆ **Minimum Value:** higher than the minimum power of one charger (1.4 kW for single-phase, 4.2 kW for three-phase) x N (N represents the number of chargers in the device group).
- ✓ **Add Secondary Chargers:** tap **Add** to display other chargers connected to the same network. Tap **OK** once you have confirmed.

Tap **Save** once you have completed the settings. Then the real-time charging details will display on the screen.

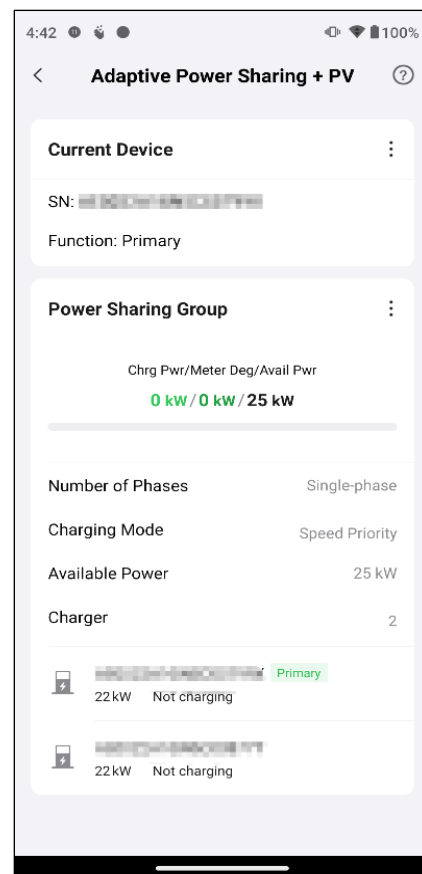
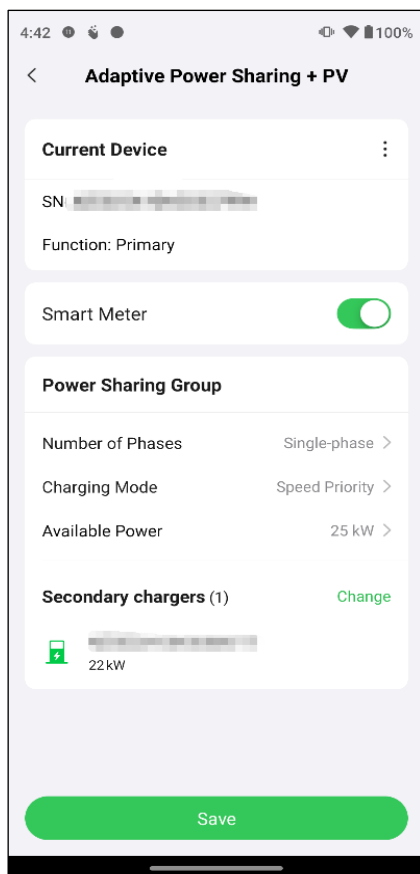

5. **Confirm configuration.** Tap the “<” icon on the upper-left corner of the charging details screen to return to the mode selection screen. The **Enabled** tag will appear on this mode, indicating that PV Hybrid mode w/multiple chargers is activated. Your chargers can now be charged according to your settings.

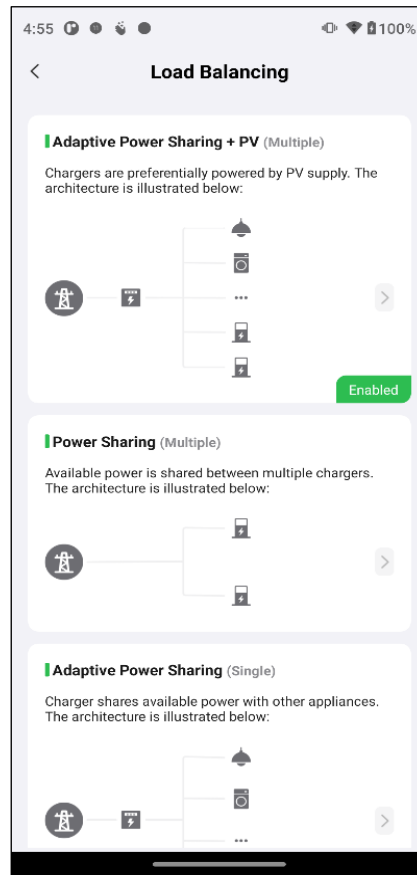

4.3.2.6 Set up EMS Mode

1. Refer to 3.3.3 to operate add chargers and configure Wi-Fi connection.
2. **Start setting.** Tap **Account > Charger**. Select the charger from the chargers list, then tap **Load Balancing > Connect to EMS**. A brief description about this mode will appear on the screen. Tap **Start Setting** to continue.

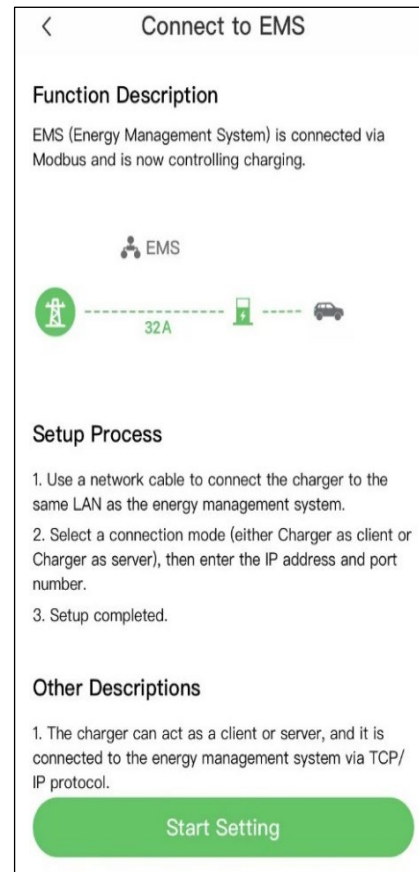
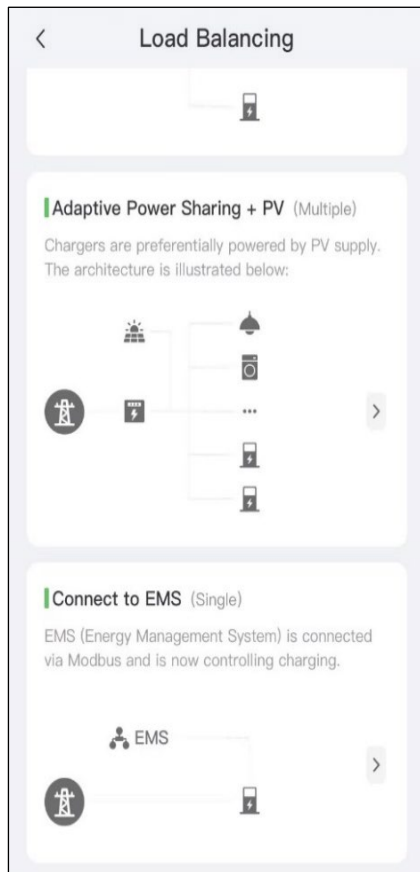

3. **Select a connection mode.** The charger can be connected to the EMS as TCP server or TCP client. Select a connection mode based on the scenarios.

- ✓ If the charger is used as a TCP server, it acts as a host, waiting for the EMS to establish a connection and send requests or data. Select **Charger as server** to continue.
- ◆ Choose the desired method to access the IP address after selecting the Charger as server mode: **automatic** or **manual**. The automatic method allows for automatic retrieval of the IP address, subnet mask, and gateway. On the other hand, the manual method requires manual input of these details.

When choose the manual method, obtain the IP Address, Subnet Mask, and Default Gateway of the charger by following the steps below:

- 1) Connect your personal computer to the Wi-Fi of the router (or connect one end of an Ethernet cable to your personal computer and the other end to the router).
- 2) Launch the browser on the computer and enter the URL of the router to log in to the web console.
- 3) Check and record the IP Address of the charger for the follow-up configuration.

Input the port number and tap **Save** to finish the setup.

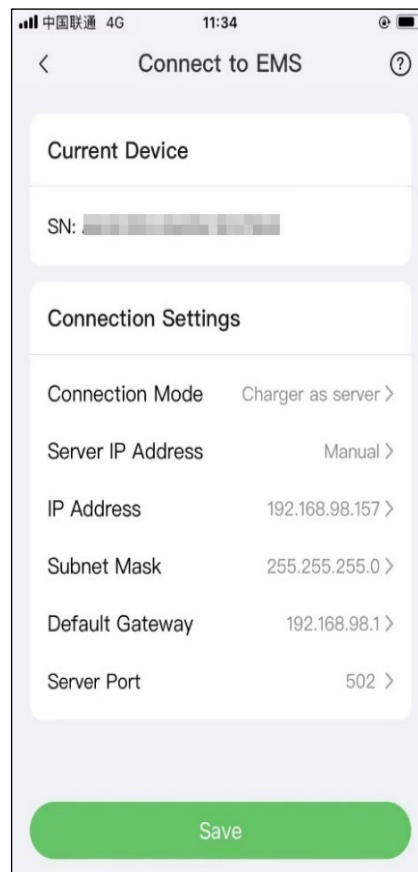
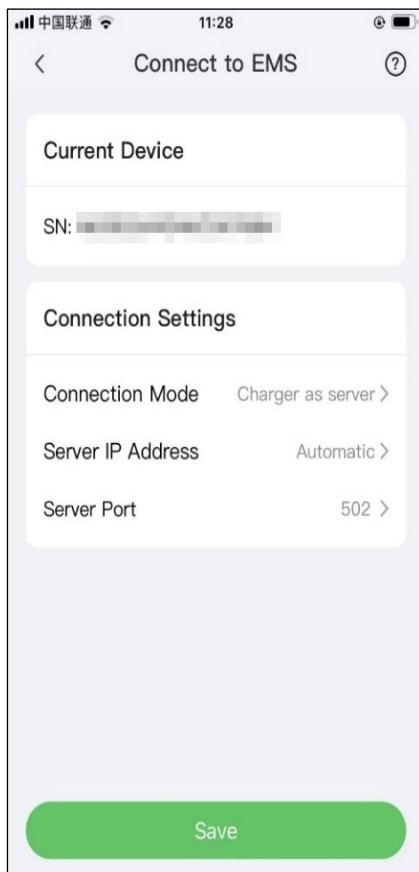

- ✓ If the charger is used as a TCP client, it initiates the connection to the EMS. Select **Charger as client** to continue. Input the server IP address and port number, then tap **Save** to finish the setup.

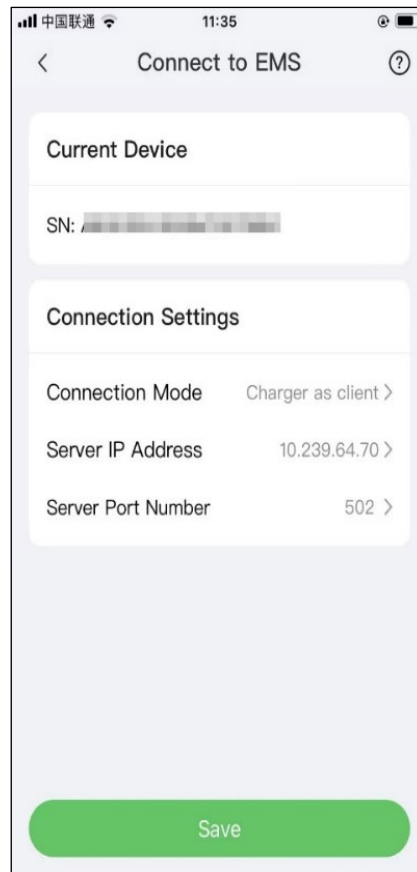

NOTE

The Modbus TCP server port is 502 by default.

- 4. Confirm configuration.** Tap the “<” icon on the upper-left corner of the Connect to EMS screen to return to the **Load Balancing** screen. The **Enabled** tag will appear on this mode, indicating that the charger has been successfully connected to the EMS.

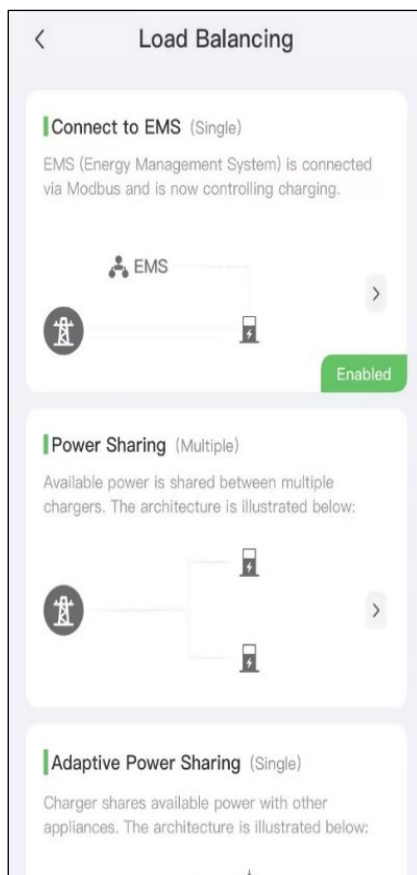

5 Modbus Register

5.1 Read Input Register

The function code is 04(hex04). The Modbus implementation enables to read 1–125 contiguous input registers. Here is an example of request and response:

Request			Response		
Function Code	1 Byte	0x04	Function Code	1 Byte	0x04
Starting Address	2 Bytes	0x0000 to 0xFFFF	Byte Count	1 Byte	2xN
Quantity of Input Register	2 Bytes	0x0001 to 0x007D	Input Register	N x Bytes	Value

5.2 Read Holding Register

The function code is 03(hex03). The Modbus implementation enables to read 1–125 contiguous holding registers. Here is an example of request and response:

Request			Response		
Function Code	1 Byte	0x03	Function Code	1 Byte	0x03
Starting Address	2 Bytes	0x0000 to 0xFFFF	Byte Count	1 Byte	2xN
Quantity of Holding Register	2 Bytes	0x0001 to 0x007D	Holding Register	N x Bytes	Value

5.3 Write Single Holding Register

The function code is 06(hex03). The Modbus implementation enables to write only 1 holding register. Here is an example of request and response:

Request			Response		
Function Code	1 Byte	0x06	Function Code	1 Byte	0x06
Register Address	2 Bytes	0x0000 to 0xFFFF	Register Address	2 Bytes	2xN
Register Value	2 Bytes	Value	Register Value	2 Bytes	Value

5.4 Write Multiple Holding Registers

The function code is 16(hex10). The Modbus implementation enables to write multiple holding registers and the data is packed into 2 bytes per register. Here is an example of request and response:

Request			Response		
Function Code	1 Byte	0x10	Function Code	1 Byte	0x10
Starting Address	2 Bytes	0x0000 to 0xFFFF	Starting Address	1 Byte	0x0000 to 0xFFFF
Quantity of Holding Register	2 Bytes	0x0001 to 0x007B	Quantity of Holding Register	2 Bytes	1 to 123 (0x7B)
Byte Count	1 Byte	2xN			
Register Value	N x 2 Bytes	Value			

5.5 Register Specifications

Modbus Parameters (Holding Register)

Register	Name	Description	Type	Unit
0000	Limit Control Mode	Charging Mode: 0 – Power Mode 1 – Current Mode	UINT16	/
0001	Link Type	Enumeration Value: 0 – RS-485 1 – TCP	UINT16	/
0002	Comm Timeout Time	Communication Timeout	UINT16	Second
0003	Slave ID	Device address, 1/bit Default: 1	UINT16	/
0004	Slave ID Confirm	Confirm the slave device address, 1/bit Default: 0	UINT16	/

NOTE

To change the slave ID, start by setting the register 0003, followed by setting the register 0004, ensuring the input data remains consistent.

Read-only Register (Input Register) Address 0100~1999

Register + Offset	Name	Description	Type	Unit
1000 + x	Charging Status (State)	Charging state 0 – Available 1 – Preparing _TagId _Ready 2 – Preparing _EV _Ready 3 – Charging 4 – Suspended EV 5 – Suspended EVSE 6 – Finishing 7 – Reserved 8 – Unavailable 9 – Unavailable FW Update 10 – Faulted 11 – Unavailable Connection Object	UINT16	/
1100 + x	Charging Voltage	Current charging voltage *Available for DC charging connector	UINT32	0.01 V
1200 + x	Charging Current	Current charging current *Available for DC charging connector	UINT32	0.01 A
1300 + x	Charging Power	Current charging power *Available for DC charging connector	UINT32	1W
1400 + x	Charge Time	The duration of charging from start to end	UINT16	Sec
1500 + x	Charged Energy	Charged energy of current charging session	UINT16	KWh/100

NOTE

For the State item in the above table, when Connector ID is 0, only Available, Unavailable, and Faulted can be set.

Read and Write Register (Holding Register) Address 1600~1999

Register + Offset	Name	Description	Type	Unit
1600 + x	Power Limit Value	Limit value of charging power	UINT32	W
1700 + x	Current Limit Value	Limit value of charging current	UINT32	0.01 A
1800 + x	Offline Power Value	Limit value of offline power	UINT32	W
1900 + x	Offline Current Value	Limit current of offline current	UINT32	0.01 A

The offset “x” marked in red above is ruled as follows:

Offset	Description
0	0# Connector, Charger
4	1# Connector
8	2# Connector
12	3# Connector
16	4# Connector
20	5# Connector
24	6# Connector
28	7# Connector
32	#8 Connector

Read-only Register (Input Register) Address 10000~18999

Register + Offset	Name	Description	Type	Unit
1y000	Charging Status (State)	Charging state 0 – Available 1 – Preparing _TagId _Ready 2 – Preparing _EV _Ready 3 – Charging 4 – Suspended EV 5 – Suspended EVSE 6 – Finishing 7 – Reserved 8 – Unavailable 9 – Unavailable FW Update 10 – Faulted 11 – Unavailable Connection Object	UINT16	/
1y001	Charging Voltage	Current charging voltage *Available for DC charging connector	UINT32	0.01 V
1y003	Charging Current	Current charging current *Available for DC charging connector	UINT32	0.01 A
1y005	Charging Power	Current charging power *Available for DC charging connector	UINT32	1 W
1y007	Charge Time	The duration of charging from start to end	UINT16	Sec
1y008	Charged Energy	Charged energy of current charging session	UINT16	KWh/100
1y009	L1 phase AC Voltage	Current charging voltage of L1 line *Available for AC charging connector	UINT32	0.01 V

Register + Offset	Name	Description	Type	Unit
1y011	L2 phase AC Voltage	Current charging voltage of L2 line *Available for AC charging connector	UINT32	0.01 V
1y013	L3 phase AC Voltage	Current charging voltage of L3 line *Available for AC charging connector	UINT32	0.01 V
1y015	L1 phase AC Current	Current charging current of L1 line *Available for AC charging connector	UINT32	0.01 A
1y017	L2 phase AC Current	Current charging current of L2 line *Available for AC charging connector	UINT32	0.01 A
1y019	L3 phase AC Current	Current charging current of L3 line *Available for AC charging connector	UINT32	0.01 A
1y021	L1 phase AC Power	Current charging power of L1 line *Available for AC charging connector	UINT32	1 W
1y023	L2 phase AC Power	Current charging power of L2 line *Available for AC charging connector	UINT32	1 W
1y025	L3 phase AC Power	Current charging power of L3 line *Available for AC charging connector	UINT32	1 W
1y100	SN	SN of charger	BIN	16 bytes

NOTE

The “y” marked in red above means the connector ID.

For the State item in the above table, when Connector ID is 0, only Available, Unavailable, and Faulted can be set.

Read and Write Register (Holding Register) Address 20000~28999

Register	Name	Description	Type	Unit
2y000	Power Limit Value	Limit value of charging power	UINT32	W
2y002	Current Limit Value	Limit value of charging current	UINT32	0.01 A
2y004	Offline Power Value	Limit value of offline power	UINT32	W
2y006	Offline Current Value	Limit current of offline current	UINT32	0.01 A

NOTE

The “y” marked in red above means the connector ID.

The connector ID and its meanings are as follows:

Connector ID	Description
0	0# Connector, Charger
1	1# Connector
2	2# Connector
3	3# Connector
4	4# Connector
5	5# Connector
6	6# Connector
7	7# Connector
8	#8 Connector

5.6 Register Addresses

Register Addresses 0000~32001 for AC Models

The AC models involved in this section are AC Wallbox, AC Ultra, AC Single Charger.

Address	Description	Read and Write Permissions	Number of Registers	Data Type	Value Description	Applicable Models
0	Charging control mode	RW	1	UINT16	Charging control modes: 0 - Power Mode 1 - Current Mode Note: For AC models, the value at address 0000 determines the corresponding charging control modes. Please set it accurately according to the value description above.	AC Wallbox, AC Ultra, AC Single Charger
2	Communication timeout	RW	1	UINT16	Unit: s	AC Ultra, AC Single Charger
100	Product type	RO	30	ASCII	Corresponding to Charge Point Model in BootNotification	AC Wallbox, AC Ultra, AC Single Charger
130	Software version number	RO	20	ASCII		AC Wallbox, AC Ultra, AC Single Charger
10000	Current status of the charger	RO	1	UINT16	0-available 8-unavailable 10-faulted	AC Wallbox, AC Ultra, AC Single Charger
10005	Charging power (active power)	RO	2	UINT32	Current charging active power	AC Wallbox, AC Ultra, AC Single Charger
10007	Charging time	RO	1	UINT32	Charging time from the start of charging to the	AC Wallbox

Address	Description	Read and Write Permissions	Number of Registers	Data Type	Value Description	Applicable Models
					current or end of charging	
10008	Charged energy	RO	1	UINT32	kWh/100	AC Wallbox
10009	L1 phase AC voltage	RO	2	UINT32	0.01V	AC Wallbox, AC Ultra, AC Single Charger
10011	L2 phase AC voltage	RO	2	UINT32	0.01V	AC Wallbox, AC Ultra, AC Single Charger
10013	L3 phase AC voltage	RO	2	UINT32	0.01V	AC Wallbox, AC Ultra, AC Single Charger
10015	L1 phase AC current	RO	2	UINT32	0.01A	AC Wallbox
10017	L2 phase AC current	RO	2	UINT32	0.01A	AC Wallbox
10019	L3 phase AC current	RO	2	UINT32	0.01A	AC Wallbox
10021	L1 phase AC power	RO	2	UINT32	1W	AC Wallbox
10023	L2 phase AC power	RO	2	UINT32	1W	AC Wallbox
10025	L3 phase AC power	RO	2	UINT32	1W	AC Wallbox
10100	SN	RO	16	ASCII	Charger SN, unit SN	AC Wallbox, AC Ultra, AC Single Charger
10116	Number of connectors	RO	1	UINT16	Number of connectors	AC Wallbox, AC Ultra, AC Single Charger

Address	Description	Read and Write Permissions	Number of Registers	Data Type	Value Description	Applicable Models
10117	Maximum charging current	RO	2	UINT32	0.01A	AC Wallbox
10119	Maximum charging power	RO	2	UINT32	1W	AC Ultra, AC Single Charger
11000	Connector charging status	RO	1	UINT16	0-available 1-preparing_Tagld Ready 2-preparing EV Ready 3-charging 4-suspendedev 5-suspendedevse 6-finishing 7-reserved 8-unavailable 10-faulted	AC Ultra, AC Single Charger
11005	Charger 1 charging power (active power)	RO	2	UINT32	Connector 1's current charging active power	AC Ultra
11009	Connector 1 AC L1 phase voltage	RO	2	UINT32	0.01V	AC Ultra, AC Single Charger
11011	Connector 1 AC L2 phase voltage	RO	2	UINT32	0.01V	AC Ultra, AC Single Charger
11013	Connector 1 AC L3 phase voltage	RO	2	UINT32	0.01V	AC Ultra, AC Single Charger
11015	Connector 1 AC L1 phase current	RO	2	UINT32	0.01A	AC Ultra, AC Single Charger
11017	Connector 1 AC L2 phase current	RO	2	UINT32	0.01A	AC Ultra, AC Single Charger
11019	Connector 1 AC L3 phase current	RO	2	UINT32	0.01A	AC Wallbox, AC Ultra,

Address	Description	Read and Write Permissions	Number of Registers	Data Type	Value Description	Applicable Models
						AC Single Charger
11021	Total charging power of AC connector	RO	2	UINT32	1W	AC Wallbox
11023	AC connector 1 total charging power	RO	2	UINT32	1W	AC Wallbox
11027	Connector 1 AC L1 phase charging power	RO	2	UINT32	1W	AC Wallbox, AC Ultra, AC Single Charger
11029	Connector 1 AC L2 phase charging power	RO	2	UINT32	1W	AC Wallbox, AC Ultra, AC Single Charger
11031	Connector 1 AC L3 phase charging power	RO	2	UINT32	1W	AC Wallbox, AC Ultra, AC Single Charger
11033	Connector 1 Current charging energy	RO	2	UINT32	1W	AC Wallbox, AC Ultra, AC Single Charger
11035	Connector 1 cumulative charging energy	RO	4	UINT64	0.1Wh The size is 4 registers. The first two registers represent the lower 4 bytes, and the last two registers represent the higher 4 bytes.	AC Wallbox, AC Ultra, AC Single Charger
11141	Fault codes (European standard)	RO	2	UINT32		AC Wallbox
11143	Fault codes (US standard)	RO	2	UINT32		AC Wallbox

Address	Description	Read and Write Permissions	Number of Registers	Data Type	Value Description	Applicable Models
11145	Charging connector type	RO	1	UINT16	4-AC_type1 5-AC_type2	AC Wallbox, AC Ultra, AC Single Charger
11147	Charging uses IdToken	RO	18	ASCII	The IdToken value used to start charging for Connector 1 still needs to be specified as 20 bytes according to the OCPP1.6 protocol and 36 bytes according to the OCPP2.0.1 protocol for authentication with the operator cloud.	AC Wallbox, AC Ultra, AC Single Charger
12000	Connector charging status	RO	1	UINT16	0-available 1-preparing_TagId Ready 2-preparing EV Ready 3-charging 4-suspendedev 5-suspendedevse 6-finishing 7-reserved 8-unavailable 10-faulted	AC Ultra
12005	Charger 2 charging power (active power)	RO	2	UINT32	Connector 2's current charging active power	AC Ultra
12009	Connector 2 AC L1 phase voltage	RO	2	UINT32	0.01V	AC Ultra
12011	Connector 2 AC L2 phase voltage	RO	2	UINT32	0.01V	AC Ultra
12013	Connector 2 AC L3 phase voltage	RO	2	UINT32	0.01V	AC Ultra

Address	Description	Read and Write Permissions	Number of Registers	Data Type	Value Description	Applicable Models
12015	Connector 2 AC L1 phase current	RO	2	UINT32	0.01A	AC Ultra, AC Single Charger
12017	Connector 2 AC L2 phase current	RO	2	UINT32	0.01A	AC Ultra, AC Single Charger
12019	Connector 2 AC L3 phase current	RO	2	UINT32	0.01A	AC Ultra, AC Single Charger
12027	Connector 2 AC L1 phase charging power	RO	2	UINT32	1W	AC Ultra, AC Single Charger
12029	Connector 2 AC L2 phase charging power	RO	2	UINT32	1W	AC Ultra, AC Single Charger
12031	Connector 2 AC L3 phase charging power	RO	2	UINT32	1W	AC Ultra, AC Single Charger
12033	Connector 2 Current charging charge level	RO	2	UINT32	1W	AC Ultra, AC Single Charger
12035	Connector 2 cumulative charging power	RO	4	UINT64	0.1Wh The size is 4 registers. The first two registers represent the lower 4 bytes, and the last two registers represent the higher 4 bytes.	AC Ultra, AC Single Charger
12145	Connector type	RO	1	UINT16	4-AC_type1 5-AC_type2	AC Ultra, AC Single Charger
12147	Charging uses IdToken	RO	18	ASCII	The IdToken value used to start charging for Connector 1 still needs to be specified as 20 bytes according to the OCPP1.6	AC Ultra, AC Single Charger

Address	Description	Read and Write Permissions	Number of Registers	Data Type	Value Description	Applicable Models
					protocol and 36 bytes according to the OCPP2.0.1 protocol for authentication with the operator cloud.	
20000	Charging power limit	RW	2	UINT32	W	AC Wallbox, AC Ultra, AC Single Charger
20002	Charging current limit	RW	2	UINT32	0.01A	AC Wallbox
20004	Offline power limit	RW	2	UINT32	W	AC Wallbox, AC Ultra, AC Single Charger
20006	Offline current limit	RW	2	UINT32	0.01A	AC Wallbox
21000	Connector 1 charging power limit	RW	2	UINT32	W	AC Wallbox, AC Ultra, AC Single Charger
21002	Connector 1 charging current limit	RW	2	UINT32	0.01A	AC Wallbox, AC Ultra, AC Single Charger
21004	Connector 1 offline power limit	RW	2	UINT32	W	AC Wallbox, AC Ultra, AC Single Charger
21006	Connector 1 offline current limit	RW	2	UINT32	0.01A	AC Wallbox, AC Ultra, AC Single Charger
21008	Phase switching control (EU)	RW	1	UINT16	0: L1/L2/L3 1: L1 2: L2	AC Single Charger

Address	Description	Read and Write Permissions	Number of Registers	Data Type	Value Description	Applicable Models
	three- phase charger)				3: L3 4: L1-L3 (IT) 5: L2-L3 (IT) 6: L1-L2 (IT) 7: L1-L2-N (IT) 8: L1-L3-N (IT)	
22000	Connector 2 charging power limit	RW	2	UINT32	W	AC Ultra
22002	Connector 2 charging current limit	RW	2	UINT32	0.01A	AC Ultra
22004	Connector 2 offline power limit	RW	2	UINT32	W	AC Ultra
22006	Connector 2 offline current limit	RW	2	UINT32	0.01A	AC Ultra
30000	Start/Stop Charging	WO	1	UINT16	0: Start 1: Stop	AC Wallbox
30001	Lock/Unlock connector	WO	1	UINT16	0: Lock connector 1: Unlock	AC Wallbox
30002	Start firmware upgrade	WO	128	ASCII	Initiating a firmware upgrade requires including a URL that supports HTTP(S) download	AC Wallbox
31000	Connector 1 Start/Stop Charging	WO	1	UINT16	0: Start 1: Stop	AC Ultra
31001	Connector 1 Lock/Unlock Charging Connector	WO	1	UINT16	0: Lock connector 1: Unlock	AC Ultra
32000	Connector 2 Start/Stop Charging	WO	1	UINT16	0: Start 1: Stop	AC Ultra

Address	Description	Read and Write Permissions	Number of Registers	Data Type	Value Description	Applicable Models
32001	Connector 2 Lock/Unlock Charging Connector	WO	1	UINT16	0: Lock connector 1: Unlock	AC Ultra

Register Addresses 0100~10121 for DC Models

The DC models involved in this section are DH240, DH300, DH480, DH600, DS480, DS600, DS960, DS1200, DS1800, DS1440, DS600L, DT300, DT500, DT800, DT1500, DC Compact, DC Fast, DC HiPower.

Address	Description	Read and Write Permissions	Data Type	Value Description	Applicable Models
100	Product type	RO	ASCII	MaxiCharger	DH240, DH300, DH480, DH600, DS480, DS600, DS960, DS1200, DS1800, DS1440, DS600L, DT300, DT500, DT800, DT1500, DC Compact, DC Fast, DC HiPower
130	Software version number	RO	ASCII		DC Compact, DC Fast, DC HiPower
150	Number of connectors	RO	UINT 16		DC HiPower
1000 + x	Current status of the charger	RO	UINT16	0-available 8-unavailable 10-faulted	DH240, DH300, DH480, DH600, DS480, DS600, DS960, DS1200, DS1800, DS1440, DS600L, DT300, DT500, DT800, DT1500, DC Compact, DC Fast, DC HiPower
1100 + x	Charging voltage	RO	UINT32	0.01V	DH240, DH300, DH480, DH600, DS480, DS600, DS960, DS1200, DS1800, DS1440, DS600L, DT300, DT500, DT800, DT1500, DC

Address	Description	Read and Write Permissions	Data Type	Value Description	Applicable Models
					Compact, DC Fast, DC HiPower
1200 + x	Charging current	RO	UINT32	0.01A	DH240, DH300, DH480, DH600, DS480, DS600, DS960, DS1200, DS1800, DS1440, DS600L, DT300, DT500, DT800, DT1500, DC Compact, DC Fast, DC HiPower
1300 + x	Charging power	RO	UINT32	W	DH240, DH300, DH480, DH600, DS480, DS600, DS960, DS1200, DS1800, DS1440, DS600L, DT300, DT500, DT800, DT1500, DC Compact, DC Fast, DC HiPower
1400 + x	Charging time	RO	UINT16	Sec/bit	DH240, DH300, DH480, DH600, DS480, DS600, DS960, DS1200, DS1800, DS1440, DS600L, DT300, DT500, DT800, DT1500, DC Compact, DC Fast, DC HiPower
1500 + x	Current charging energy	RO	UINT16	kWh/100	DH240, DH300, DH480, DH600, DS480, DS600, DS960, DS1200, DS1800, DS1440, DS600L, DT300, DT500, DT800, DT1500, DC Compact, DC Fast, DC HiPower
1600 + x	Charging power limit	RW	UINT32	W	DH240, DH300, DH480, DH600, DS480, DS600, DS960, DS1200, DS1800, DS1440, DS600L, DT300, DT500, DT800, DT1500, DC

Address	Description	Read and Write Permissions	Data Type	Value Description	Applicable Models
					Compact, DC Fast, DC HiPower
1700 + x	Charging current limit	RW	UINT32	0.01A	DH240, DH300, DH480, DH600, DS480, DS600, DS960, DS1200, DS1800, DS1440, DS600L, DT300, DT500, DT800, DT1500, DC Compact, DC Fast, DC HiPower
1800 + x	Offline charging power limit	RW	UINT32	W	DH240, DH300, DH480, DH600, DS480, DS600, DS960, DS1200, DS1800, DS1440, DS600L, DT300, DT500, DT800, DT1500, DC Compact, DC Fast, DC HiPower
1900 + x	Offline charging current limit	RW	UINT32	0.01A	DH240, DH300, DH480, DH600, DS480, DS600, DS960, DS1200, DS1800, DS1440, DS600L, DT300, DT500, DT800, DT1500, DC Compact, DC Fast, DC HiPower
2200 + x	Vehicle SOC	RO	UINT16	1%	DH240, DH300, DH480, DH600, DS480, DS600, DS960, DS1200, DS1800, DS1440, DS600L, DT300, DT500, DT800, DT1500, DC Compact, DC Fast, DC HiPower
2400	RFID card number	RW	ASCII	RFID card number Maximum of 16 connectors, with 18 registers per connector (306 registers in total)	DC Compact, DC Fast

Address	Description	Read and Write Permissions	Data Type	Value Description	Applicable Models
2900	Maximum inductive reactive power of the charger (+)	RO	UINT32	0.1kvar	DH240, DH300, DH480, DH600, DS480, DS600, DS960, DS1200, DS1800, DS1440, DS600L, DT300, DT500, DT800, DT1500
2902	Maximum capacitive reactive power of the charger (-)	RO	UINT32	0.1kvar	DH240, DH300, DH480, DH600, DS600, DS960, DS1200, DS1800, DS1440, DS600L, DT300, DT500, DT800, DT1500
10100	Charger SN	RO	BIN	32 bytes	DH240, DH300, DH480, DH600, DS480, DS600, DS960, DS1200, DS1800, DS1440, DS600L, DT300, DT500, DT800, DT1500, DC Compact, DC Fast, DC HiPower
10116	Number of connectors	RO	UINT16		DH240, DH300, DH480, DH600, DS480, DS600, DS960, DS1200, DS1800, DS1440, DS600L, DT300, DT500, DT800, DT1500, DC Compact, DC Fast
10119	Maximum allowed charging power of the charger (connector)	RO	UINT32	W	DH240, DH300, DH480, DH600, DS480, DS600, DS960, DS1200, DS1800, DS1440, DS600L, DT300, DT500, DT800, DT1500, DC Compact, DC Fast
10121	Maximum allowed offline charging power of the charger (connector)	RO	UINT32	W	DC Compact, DC Fast

The offset "x" marked in red above is ruled as follows:

Offset	Description
0	0# Connector, Charger
4	1# Connector
8	2# Connector
12	3# Connector
16	4# Connector
20	5# Connector
24	6# Connector
28	7# Connector
32	#8 Connector

6 Energy Management Strategies

Autel energy management system solution is developed through repeated configuration and verification. Below are the Autel energy management system strategies.

DLB Mode

- Reserved Power = Minimum Charging Power (Single-phase:1.4 kW, Three-phase:4.2 kW)
- Allocated Power for Each Offline Charger = Maximum Power Configured in DLB Setting / Number of Chargers Configured in the DLB System
- Offline Power = Allocated Power for Each Offline Charger x Number of Offline Chargers
- Allocated Power for Each Remaining Online Charger in Charging = (Maximum Power Configured in DLB Setting - Reserved Power - Offline Power) / Number of Online Chargers in Charging

NOTE

When all chargers are online and charging, the reserved power is 0.

ALM Mode

- Allocable Power = Maximum Power Configured in ALM Setting x (1 - 5% - Reserved Power Percentage in the Charging Station in ALM Setting)
- Offline Power = Minimum Charging Power for Charger x Number of Offline Chargers
- Allocated Power for Each Online Charger in Charging = (Allocable Power – Household Loads – Offline Power) / Number of Online Chargers in Charging
- Allocated Power for Each Offline Charger = Minimum Charging Power for Charger

NOTE

If the calculated online allocated power is lower than the minimum charging power, the last activated charger will pause charging and will resume charging when the online chargers can be charged using the minimum charging power.

If the meter is abnormal, all chargers will pause charging.

Minimum Power

- a) When using a single-phase power supply, the minimum power is 1.4 kW.
- b) When using a three-phase power supply, the minimum power is 4.2 kW.

PV Hybrid Mode

- **Full Green Charging Mode**

Allocated Power = Solar Energy – Household Loads

- **Green Priority Charging Mode**

- a) **When Solar Energy > Household Loads + Minimum Charging Power for Charger**

- Allocated Power = Solar Energy – Household Loads

- b) **When Solar Energy \leq Household Loads + Minimum Charging Power for Charger**

- Allocated Power = Minimum Charging Power for Charger

- **Speed Priority Charging Mode**

Allocated Power = Solar Energy + Available Energy – Household Loads

AUTEL®